



GE Fanuc Automation

Computer Numerical Control Products

Series 15 / 150 – Model B

Maintenance Manual

GFZ-62075E/04

May 1998

Warnings, Cautions, and Notes as Used in this Publication

Warning

Warning notices are used in this publication to emphasize that hazardous voltages, currents, temperatures, or other conditions that could cause personal injury exist in this equipment or may be associated with its use.

In situations where inattention could cause either personal injury or damage to equipment, a Warning notice is used.

Caution

Caution notices are used where equipment might be damaged if care is not taken.

Note

Notes merely call attention to information that is especially significant to understanding and operating the equipment.

This document is based on information available at the time of its publication. While efforts have been made to be accurate, the information contained herein does not purport to cover all details or variations in hardware or software, nor to provide for every possible contingency in connection with installation, operation, or maintenance. Features may be described herein which are not present in all hardware and software systems. GE Fanuc Automation assumes no obligation of notice to holders of this document with respect to changes subsequently made.

GE Fanuc Automation makes no representation or warranty, expressed, implied, or statutory with respect to, and assumes no responsibility for the accuracy, completeness, sufficiency, or usefulness of the information contained herein. No warranties of merchantability or fitness for purpose shall apply.

SAFETY PRECAUTIONS

This section describes the safety precautions related to the use of CNC units. It is essential that these precautions be observed by users to ensure the safe operation of machines equipped with a CNC unit (all descriptions in this section assume this configuration).

CNC maintenance involves various dangers. CNC maintenance must be undertaken only by a qualified technician.

Users must also observe the safety precautions related to the machine, as described in the relevant manual supplied by the machine tool builder.

Before checking the operation of the machine, take time to become familiar with the manuals provided by the machine tool builder and FANUC.

Contents

1. DEFINITION OF WARNING, CAUTION, AND NOTE	s-2
2. WARNINGS RELATED TO CHECK OPERATION	s-3
3. WARNINGS RELATED TO REPLACEMENT	s-5
4. WARNINGS RELATED TO PARAMETERS	s-6
5. WARNINGS AND NOTES RELATED TO DAILY MAINTENANCE	s-7

1

DEFINITION OF WARNING, CAUTION, AND NOTE

This manual includes safety precautions for protecting the maintenance personnel (herein referred to as the user) and preventing damage to the machine. Precautions are classified into Warnings and Cautions according to their bearing on safety. Also, supplementary information is described as a Note. Read the Warning, Caution, and Note thoroughly before attempting to use the machine.

WARNING

Applied when there is a danger of the user being injured or when there is a damage of both the user being injured and the equipment being damaged if the approved procedure is not observed.

CAUTION

Applied when there is a danger of the equipment being damaged, if the approved procedure is not observed.

NOTE

The Note is used to indicate supplementary information other than Warning and Caution.

- **Read this manual carefully, and store it in a safe place.**

2 WARNINGS RELATED TO CHECK OPERATION

WARNING

1. When checking the operation of the machine with the cover removed
 - (1) The user's clothing could become caught in the spindle or other components, thus presenting a danger of injury. When checking the operation, stand away from the machine to ensure that your clothing does not become tangled in the spindle or other components.
 - (2) When checking the operation, perform idle operation without workpiece. When a workpiece is mounted in the machine, a malfunction could cause the workpiece to be dropped or destroy the tool tip, possibly scattering fragments throughout the area. This presents a serious danger of injury. Therefore, stand in a safe location when checking the operation.
2. When checking the machine operation with the power magnetics cabinet door opened
 - (1) The power magnetics cabinet has a high-voltage section (carrying a  mark). Never touch the high-voltage section. The high-voltage section presents a severe risk of electric shock. Before starting any check of the operation, confirm that the cover is mounted on the high-voltage section. When the high-voltage section itself must be checked, note that touching a terminal presents a severe danger of electric shock.
 - (2) Within the power magnetics cabinet, internal units present potentially injurious corners and projections. Be careful when working inside the power magnetics cabinet.
3. Never attempt to machine a workpiece without first checking the operation of the machine. Before starting a production run, ensure that the machine is operating correctly by performing a trial run using, for example, the single block, feedrate override, or machine lock function or by operating the machine with neither a tool nor workpiece mounted. Failure to confirm the correct operation of the machine may result in the machine behaving unexpectedly, possibly causing damage to the workpiece and/or machine itself, or injury to the user.
4. Before operating the machine, thoroughly check the entered data. Operating the machine with incorrectly specified data may result in the machine behaving unexpectedly, possibly causing damage to the workpiece and/or machine itself, or injury to the user.

WARNING

- 5.** Ensure that the specified feedrate is appropriate for the intended operation. Generally, for each machine, there is a maximum allowable feedrate. The appropriate feedrate varies with the intended operation. Refer to the manual provided with the machine to determine the maximum allowable feedrate. If a machine is run at other than the correct speed, it may behave unexpectedly, possibly causing damage to the workpiece and/or machine itself, or injury to the user.
- 6.** When using a tool compensation function, thoroughly check the direction and amount of compensation.
Operating the machine with incorrectly specified data may result in the machine behaving unexpectedly, possibly causing damage to the workpiece and/or machine itself, or injury to the user.

3 WARNINGS RELATED TO REPLACEMENT

WARNING

1. Always turn off the power to the CNC and the main power to the power magnetics cabinet. If only the power to the CNC is turned off, power may continue to be supplied to the serve section. In such a case, replacing a unit may damage the unit, while also presenting a danger of electric shock.
2. When a heavy unit is to be replaced, the task must be undertaken by two persons. If the replacement is attempted by only one person, the replacement unit could slip and fall, possibly causing injury.
3. After the power is turned off, the servo amplifier and spindle amplifier may retain voltages for a while, such that there is a danger of electric shock even while the amplifier is turned off. Allow at least twenty minutes after turning off the power for these residual voltages to dissipate.
4. When replacing a unit, ensure that the new unit has the same parameter and other settings as the old unit. (For details, refer to the manual provided with the machine.) Otherwise, unpredictable machine movement could damage the workpiece or the machine itself, and present a danger of injury.

4

WARNINGS RELATED TO PARAMETERS

WARNING

1. When machining a workpiece for the first time after modifying a parameter, close the machine cover. Never use the automatic operation function immediately after such a modification. Instead, confirm normal machine operation by using functions such as the single block function, feedrate override function, and machine lock function, or by operating the machine without mounting a tool and workpiece. If the machine is used before confirming that it operates normally, the machine may move unpredictably, possibly damaging the machine or workpiece, and presenting a risk of injury.
2. The CNC and PMC parameters are set to their optimal values, so that those parameters usually need not be modified. When a parameter must be modified for some reason, ensure that you fully understand the function of that parameter before attempting to modify it. If a parameter is set incorrectly, the machine may move unpredictably, possibly damaging the machine or workpiece, and presenting a risk of injury.

5

WARNINGS AND NOTES RELATED TO DAILY MAINTENANCE

WARNING

1. Memory backup battery replacement

When replacing the memory backup batteries, keep the power to the machine (CNC) turned on, and apply an emergency stop to the machine. Because this work is performed with the power on and the cabinet open, only those personnel who have received approved safety and maintenance training may perform this work.

When replacing the batteries, be careful not to touch the high-voltage circuits (marked  and fitted with an insulating cover).

Touching the uncovered high-voltage circuits presents an extremely dangerous electric shock hazard.

NOTE

The CNC uses batteries to preserve the contents of its memory, because it must retain data such as programs, offsets, and parameters even while external power is not applied.

If the battery voltage drops, a low battery voltage alarm is displayed on the machine operator's panel or CRT screen.

When a low battery voltage alarm is displayed, replace the batteries within a week. Otherwise, the contents of the CNC's memory will be lost.

To replace the battery, see the procedure described in Section 2.8 of this manual.

WARNING**2. Absolute pulse coder battery replacement**

When replacing the memory backup batteries, keep the power to the machine (CNC) turned on, and apply an emergency stop to the machine. Because this work is performed with the power on and the cabinet open, only those personnel who have received approved safety and maintenance training may perform this work.

When replacing the batteries, be careful not to touch the high-voltage circuits (marked  and fitted with an insulating cover).

Touching the uncovered high-voltage circuits presents an extremely dangerous electric shock hazard.

NOTE

The absolute pulse coder uses batteries to preserve its absolute position.

If the battery voltage drops, a low battery voltage alarm is displayed on the machine operator's panel or CRT screen.

When a low battery voltage alarm is displayed, replace the batteries within a week. Otherwise, the absolute position data held by the pulse coder will be lost.

To replace the battery, see the procedure described in Section 2.8 of this manual.

WARNING**3. Fuse replacement**

Before replacing a blown fuse, however, it is necessary to locate and remove the cause of the blown fuse.

For this reason, only those personnel who have received approved safety and maintenance training may perform this work.

When replacing a fuse with the cabinet open, be careful not to touch the high-voltage circuits (marked  and fitted with an insulating cover).

Touching an uncovered high-voltage circuit presents an extremely dangerous electric shock hazard.

SAFETY PRECAUTIONS	s-1
PREFACE	p-1
1. OPERATION OF MDI PANEL	1
1.1 OPERATION OF MDI PANEL	2
1.1.1 Screen Transition Chart	2
1.2 DISPLAYING SYSTEM CONFIGURATIONS	9
1.2.1 Displaying Method	9
1.2.2 Software Information	9
1.2.3 Slot Information	10
1.2.4 Module Information	12
1.3 ALARM HISTORY DISPLAY	13
1.3.1 Display Method	13
1.3.2 Alarm History Screen	13
1.3.3 Display Format of History Data	13
1.3.4 Restrictions	14
1.4 HELP FUNCTION	15
1.4.1 General	15
1.4.2 Operation	15
1.5 DIAGNOSIS FUNCTION	19
1.5.1 Displaying the Diagnosis Screen	19
1.5.2 Displaying the Status when it Appears that a Command is not being Executed	19
1.6 NC STATUS DISPLAY	28
1.7 WAVEFORM DIAGNOSIS FUNCTION	30
1.7.1 Display of Wave Diagnosis (Graph) Screen	30
1.7.2 Setting the Waveform Diagnosis Parameters	30
1.7.3 Starting or Terminating Data Sampling	34
1.7.4 Waveform Display	34
1.7.5 Editing a Displayed Waveform	34
1.7.6 Erasing a Displayed Waveform	34
1.8 OPERATING MONITOR SCREEN	35
1.8.1 Display Method	35
1.9 INTERNAL POSITION COMPENSATION DATA DISPLAY FUNCTION	36
1.9.1 Display Method	36
1.9.2 Display Data	36
1.10 OPERATION HISTORY	41
1.10.1 Display Method	41
1.10.2 Soft Key Operation	41
1.10.3 Select DI/DO Screen	44
1.10.4 Related Parameters	45
1.11 OPERATION LIST	46
2. HARDWARE	51
2.1 STRUCTURE	52
2.2 OUTLINE OF HARDWARE	53
2.3 TOTAL CONNECTION	56

2.4	INTER-MACHINE CONNECTION	68
2.4.1	CRT/MDI Unit	68
2.4.2	Reader/Puncher Interface	71
2.4.3	Manual Pulse Generator	72
2.4.4	I/O Link	73
2.4.5	Servo Interface	76
2.4.6	Connections by Type of Detectors	77
2.4.7	Combining Serial Spindle and Analog Spindle	79
2.4.8	Connection to α Serial Spindle Amplifier	80
2.4.9	Connection to Analog Spindle Amplifier	81
2.4.10	Remote Buffer Interface	82
2.4.11	High-speed DI Signal Interface	84
2.4.12	Environmental Requirement	85
2.4.13	Power Capacity	86
2.4.14	Action Against Noise	86
2.5	LIGHTING OF ALARM LEDS ON PCBS	92
2.5.1	Configuration of the Power Supply Unit	92
2.5.2	Configuration of the CPU Board (MAIN-B)	96
2.5.3	Configuration of the Main CPU Board (MAIN-A)	100
2.5.4	Configuration of the Upgraded Main CPU Board (MAIN-C)	104
2.5.5	Configuration of the High-speed Multiaxis Main CPU Board (MAX MAIN-A)	107
2.5.6	Configuration of the Level Up Multiaxis Main CPU Board (MAX MAIN-C)	111
2.5.7	Configuration of the PMC-NA Board	115
2.5.8	Configuration of the PMC-NA Board with or without the Conversational Function	118
2.5.9	Configuration of the PMC-NB Board with or without the Conversational Function	122
2.5.10	Configuration of the PMC-NB/NB2 Board with or without the Conversational Function	126
2.5.11	Configuration of the Axis CPU Board (ACPU)	130
2.5.12	Configuration of the Multiaxis Buffer Board	133
2.5.13	Configuration of the RISC Board	134
2.5.14	Configuration of the RISC Board	137
2.5.15	Configuration of the Sub-CPU Board (SUB-A)	140
2.5.16	Configuration of the Standard Multiaxis Sub-CPU Board (MAX SUB-B)	143
2.5.17	Configuration of the Upgraded Sub-CPU Board (SUB-C)	146
2.5.18	Configuration of Additional Axis (ADAX) Board	149
2.5.19	Configuration of the Option 1 Board	152
2.5.20	OSI Ethernet Board Configuration (10 Base 2)	156
2.5.21	OSI Ethernet Board Configuration (10 Base 5)	158
2.5.22	Alarm LED Display (Red) in the Event of an Error	160
2.5.23	Alarm LED (Red) Display in the Event of an Error Occurring in the Connection Unit/Operator's Panel Connection Unit	161
2.6	LIST OF THE PCBS AND UNITS	163
2.6.1	Control Unit Rack	163
2.6.2	Power Supply Unit	164
2.6.3	Control Unit PCB	164
2.6.4	Back Panel PCB	165
2.6.5	Module (For Main CPU Board)	166
2.6.6	Module (For PMC/Conversational Board)	167
2.6.7	Module (For Sub CPU Board, Additional Axis Board, or Axis CPU Board)	168
2.6.8	Module (For RISC Board)	168

2.6.9	Module (Option 1 Board)	169
2.6.10	Module (OSI Ethernet Board)	169
2.6.11	Display Unit	170
2.6.12	External Control Unit (Except I/O Unit)	173
2.7	HOW TO REPLACE THE MODULES	176
2.7.1	Removing	176
2.7.2	Insertion	176
2.8	HOW TO REPLACE THE BATTERIES	177
2.8.1	Replace the Battery for Memory Back Up	177
2.8.2	Replacing Batteries for Separate Absolute Pulse Coder	178
2.9	HOW TO REPLACE FAN MOTOR	179
2.10	FUSE REPLACEMENT IN POWER SUPPLY UNIT	181
2.11	MAINTENANCE OF HEAT PIPE TYPE HEAT EXCHANGER	182
2.12	ADJUSTING THE LIQUID-CRYSTAL DISPLAYS	185
2.12.1	9.5" LCD	185
2.12.2	10" LCD	185
2.12.3	10" PDP	186
2.12.4	9" PDP	186
2.13	REPLACING THE FUSES OF THE LIQUID-CRYSTAL DISPLAYS	187
2.13.1	9.5" LCD, 10.4" LCD (Graphic Function Built-in Type or for MMC-IV)	187
2.13.2	10" LCD	187
2.14	REPLACING THE LCD BACKLIGHT	188
2.15	HOW TO REPLACE THE CRT DISPLAY	189
2.16	HOW TO REPLACE THE MDI KEYBOARD	190
2.17	HOW TO REPLACE THE CARD CAGE IN THE CONTROL UNIT	191
2.18	HANDLING MEMORY CARDS	192
2.18.1	Overview	192
2.18.2	Notes on Use	192
2.18.3	Names and Functions of the Components	193
2.18.4	Using Memory Cards	194
2.18.5	Replacing the Battery	195
3.	INPUT AND OUTPUT OF DATA	196
3.1	SETTING THE PARAMETERS REQUIRED FOR INPUT/OUTPUT	197
3.2	DATA INPUT/OUTPUT	200
3.2.1	Checking the Parameters Required for Data Input/Output	200
3.2.2	Data Output	208
3.2.2.1	CNC parameter output	208
3.2.2.2	Outputting PMC parameter	208
3.2.2.3	Pitch error compensation data output	212
3.2.2.4	Custom macro variable value output	212
3.2.2.5	Tool offset data output	213
3.2.2.6	Part program output	213
3.2.3	Data Input	214
3.2.3.1	CNC parameter input	214
3.2.3.2	Inputting CNC parameter	214
3.2.3.3	Inputting PMC data	216

3.2.3.4	Pitch error compensation data input	218
3.2.3.5	Custom macro variable value input	218
3.2.3.6	Tool offset data input	219
3.2.3.7	Part program registration	220
3.2.4	15-MFB Data Input/Output	222
3.2.4.1	Conversational data input/output	222
3.2.4.2	Conversational data input	222
3.2.4.3	Conversational data output	223
4.	INTERFACE BETWEEN NC AND PMC	224
4.1	GENERAL OF INTERFACE	225
4.2	SPECIFICATION OF PMC	226
4.2.1	Specification	226
4.2.2	Address	227
4.2.3	Built-in Debug Function	228
4.2.4	System Reserve Area in Internal Relay	228
4.2.5	Execution Period of PMC	229
4.3	PMC SYSTEM CONFIGURATION	230
4.4	PMC SCREEN	231
4.4.1	Display Method	231
4.4.2	PMCLAD Screen	233
4.4.3	PMCDGN Screen	237
4.4.4	PMCRAM Screen	245
4.5	SIGNAL AND SYMBOL CORRESPONDENCE TABLE	253
5.	TROUBLESHOOTING	270
5.1	CORRECTIVE ACTION FOR FAILURES	271
5.1.1	Investigating the Conditions under which Failure Occurred	271
5.2	POWER CANNOT BE TURNED ON	273
5.3	NO MANUAL OPERATION NOR AUTOMATIC OPERATION CAN BE EXECUTED	276
5.4	JOG OPERATION CANNOT BE DONE	281
5.5	HANDLE OPERATION CANNOT BE DONE	285
5.6	AUTOMATIC OPERATION CANNOT BE DONE	288
5.7	CYCLE START LED SIGNAL HAS TURNED OFF	295
5.8	NOTHING IS DISPLAYED ON CRT	297
5.9	SR805 TO SR874 (RELATED TO READER/PUNCH INTERFACE)	298
5.10	REFERENCE POSITION DEVIATES	310
5.11	PS200 (GRID SYNCHRONOUS IS FAILED)	311
5.12	ALARM OT32 (NEED ZRN (ABS PDR))	314
5.13	ALARM SV101 (DATA ERROR (ABS PCDR))	315
5.14	ALARM OT34 (BATTERY ZERO (ABS PCDR))	316
5.15	ALARM SV110 (PULSE CODER ALARM1 (SERIAL))	317
5.16	ALARM SV114 (ABNORMAL REV DATA)	317
5.17	ALARM SV115 (ABNORMAL COMMUNICATION (SERIAL PCDR))	318
5.18	ALARM SV23 (SV OVER LOAD)	319
5.19	ALARM 700 (OVERHEAT AT CONTROL SIDE)	321
5.20	ALARM OT117 (SPINDLE SPEED FLUCTUATION DETECTION ALARM)	322
5.21	ALARM OT300 (SPINDLE SERIAL LINK CANNOT BE STARTED)	323

APPENDIX

A. MAINTENANCE PARTS	329
A.1 MAINTENANCE PARTS FOR THE FANUC Series 15-B	330
B. BOOT SYSTEM	335
B.1 OVERVIEW	336
B.1.1 Power-up Processing Sequence Display	336
B.1.2 Starting the Boot System	337
B.1.3 System File and User File	338
B.1.4 Memory Cards for Use with the Boot System	340
B.2 SCREEN CONFIGURATION AND OPERATING PROCEDURE	341
B.2.1 SYSTEM DATA LOADING Screen	342
B.2.2 SYSTEM DATA CHECK Screen	344
B.2.3 SYSTEM DATA SAVE Screen	347
B.2.4 SRAM DATA BACKUP Screen	348
B.2.5 MEMORY CARD FORMAT Function	353
B.2.6 LOAD BASIC SYSTEM	354
B.3 ERROR MESSAGES AND REQUIRED COUNTERMEASURES	355
B.4 SYSTEM ALARMS AND REQUIRED COUNTERMEASURES	357
C. ERROR CODE TABLE	363
C.1 ALARM LIST (CNC)	364
C.2 ALARM LIST (PMC)	383
C.3 PMC ERRORS	388
D. WARNING MESSAGE LIST	395

PREFACE

Description of this manual

This manual is organized as described below.

1. CRT/MDI display and operation

This chapter covers those items, displayed on the screen, that are related to maintenance. A list of all supported operations is also provided at the end of this chapter.

2. Hardware

This chapter covers hardware-related items, including the hardware configuration, connection, and NC status indicated on printed circuit boards. A list of all units is also provided as well as an explanation of how to replace each unit.

3. Data input/output

This chapter describes the input/output of data, including programs, parameters, and tool compensation data, as well as the input/output procedures for conversational data.

4. Interface between the NC and PMC

This chapter describes the PMC specifications, the system configuration, and the signals used by the PMC.

5. Trouble shooting

This chapter describes the procedures to be followed in the event of certain problems occurring, for example, if the power cannot be turned on or if manual operation cannot be performed. Countermeasures to be applied in the event of alarms being output are also described.

APPENDIX

The appendix consists of a list of all alarms, a list of maintenance parts, and boot system.

This manual does not provide a parameter list. If necessary, refer to the separate PARAMETER MANUAL (B-62560E).

The maintenance of the servo unit, spindle motor, and amplifier is not covered by this manual. For information related to the maintenance of these units, refer to the relevant manuals.

This manual describes all optional functions. Refer to the manual provided by the machine tool builder for details of any options with which the installed machine tool is provided.

Depending on the model, some functions described in this manual may not be available. For details, refer to the relevant descriptions.

Applicable models

This manual can be used with the following models.
The abbreviated names may be used.

Product Name	Abbreviations		
FANUC Series 15-TB	15-TB	15-T	Series 15
FANUC Series 15-TFB	15-TFB		
FANUC Series 15TED-MODEL B-4 (*1)	15TED		
FANUC Series 15TEE-MODEL B-4 (*1)	15TEE		
FANUC Series 15TEF-MODEL B-4 (*1)	15TEF		
FANUC Series 15-MB	15-MB	15-M	
FANUC Series 15-MFB	15-MFB		
FANUC Series 15MEK-MODEL B-4 (*1)	15MEK		
FANUC Series 15MEL-MODEL B-4 (*1)	15MEL		
FANUC Series 15-TTB	15-TTB	15-TT	
FANUC Series 15-TTFB	15-TTFB		
FANUC Series 150-TB	150-TB	150-T	Series 150
FANUC Series 150-TTB	150-TTB	150-TT	
FANUC Series 150-MB	150-MB	150-M	

(*1) With 15TED, 15TEE, and 15TEF, some options are not available.

Moreover, the following PC boards cannot be used:

- Sub-CPU board
- RISC board
- OSI ethernet board

(*2) The MMC board can be used only with the Series 150.

Series of CNC

Product Name	Series	
FANUC Series 15-TB	T series	For Lathe
FANUC Series 15-TFB		
FANUC Series 15TED-MODEL B-4		
FANUC Series 15TEE-MODEL B-4		
FANUC Series 15TEF-MODEL B-4		
FANUC Series 150-TB		
FANUC Series 15-TTB	TT series	
FANUC Series 15-TTFB		
FANUC Series 150-TTB		
FANUC Series 15-MB	M series	For Machining center
FANUC Series 15-MFB		
FANUC Series 15MEK-MODEL B-4		
FANUC Series 15MEL-MODEL B-4		
FANUC Series 150-MB		

Manuals related to Series 15/150-MODEL B

Manuals related to FANUC Series 15/150-MODEL B are as follows. This manual is marked with an asterisk (*).

List of manuals related to Series 15/150-MODEL B

Manual Name	Specification Number	
FANUC Series 15-TB/TFB/TTB/TTFB DESCRIPTIONS	B-62072E	
FANUC Series 15/150-MODEL B For Machining Center DESCRIPTIONS	B-62082E	
FANUC Series 15/150-MODEL B CONNECTION MANUAL	B-62073E	
FANUC Series 15/150-MODEL B CONNECTION MANUAL (BMI Interface)	B-62073E-1	
FANUC Series 15-MODEL B For Lathe OPERATOR'S MANUAL (Programming)	B-62554E	
FANUC Series 15-MODEL B For Lathe OPERATOR'S MANUAL (Operation)	B-62554E-1	
FANUC Series 15/150-MODEL B For Machining Center OPERATOR'S MANUAL (Programming)	B-62564E	
FANUC Series 15/150-MODEL B For Machining Center OPERATOR'S MANUAL (Operation)	B-62564E-1	
FANUC Series 15/150-MODEL B PARAMETER MANUAL	B-62560E	
FANUC Series 15/150-MODEL B MAINTENANCE MANUAL	B-62075E	*
FANUC Series 15-MODEL B DESCRIPTIONS (Supplement for Remote Buffer)	B-62072E-1	
FANUC Series 15-MODEL B PROGRAMMING MANUAL (Macro Compiler / Macro Executer)	B-62073E-2	
PMC		
FANUC PMC-MODEL N/NA PROGRAMMING MANUAL (Ladder Language)	B-61013E	
FANUC PMC-MODEL NB/NB2 PROGRAMMING MANUAL (Ladder Language)	B-61863E	
FANUC PMC-MODEL N/NA PROGRAMMING MANUAL (C Language)	B-61013E-2	
FANUC PMC-MODEL NB PROGRAMMING MANUAL (C Language)	B-61863E-1	
FANUC PMC-MODEL N/NA PROGRAMMING MANUAL (C Language – Tool Management Library)	B-61013E-4	
Conversational Automatic Programming Function		
CONVERSATIONAL AUTOMATIC PROGRAMMING FUNCTION FOR MACHINING CENTER (Series 15-MF/MFB) PROGRAMMING MANUAL	B-61263E	
CONVERSATIONAL AUTOMATIC PROGRAMMING FUNCTION FOR MACHINING CENTER (Series 15-MF/MFB) OPERATOR'S MANUAL	B-61264E	
CONVERSATIONAL AUTOMATIC PROGRAMMING FUNCTION FOR LATHE (Series 15-TF/TTF/TFB/TTFB) OPERATOR'S MANUAL	B-61234E	
CONVERSATIONAL AUTOMATIC PROGRAMMING FUNCTION II FOR LATHE (Series 15-TFB/TTFB) OPERATOR'S MANUAL	B-61804E-2	
Tracing / Digitizing		
FANUC Series 15-MB DESCRIPTIONS (Supplement for Tracing / Digitizing)	B-62472E	
FANUC Series 15-MB CONNECTION MANUAL (Supplement for Tracing / Digitizing)	B-62473E	
FANUC Series 15-MB OPERATOR'S MANUAL (Supplement for Tracing / Digitizing)	B-62474E	
Gas, Laser Plasma Cutting Machine		
FANUC Series 15-MB DESCRIPTIONS (FOR GAS, LASER PLASMA CUTTING MACHINE)	B-62082EN-1	
Multi-Teaching Function		
FANUC Series 15-MB CONNECTION MANUAL (Multi-Teaching Function)	B-62083E-1	
Multiple-axis and Multiple-path Control Function		
FANUC Series 15-TTB OPERATOR'S MANUAL (Supplement Explanations for Multiple-axis and Multiple-path Control Function)	B-62074E-1	

1 OPERATION OF MDI PANEL

This chapter describes how to display and operate each screen, and so forth.

- 1.1 OPERATION OF MDI PANEL 2
- 1.2 DISPLAYING SYSTEM CONFIGURATIONS 9
- 1.3 ALARM HISTORY DISPLAY 13
- 1.4 HELP FUNCTION 15
- 1.5 DIAGNOSIS FUNCTION 19
- 1.6 NC STATUS DISPLAY 28
- 1.7 WAVEFORM DIAGNOSIS FUNCTION 30
- 1.8 OPERATING MONITOR SCREEN 35
- 1.9 INTERNAL POSITION COMPENSATION DATA
DISPLAY FUNCTION 36
- 1.10 OPERATION HISTORY 41
- 1.11 OPERATION LIST 46

1.1 OPERATION OF MDI PANEL

1.1.1 Screen Transition Chart

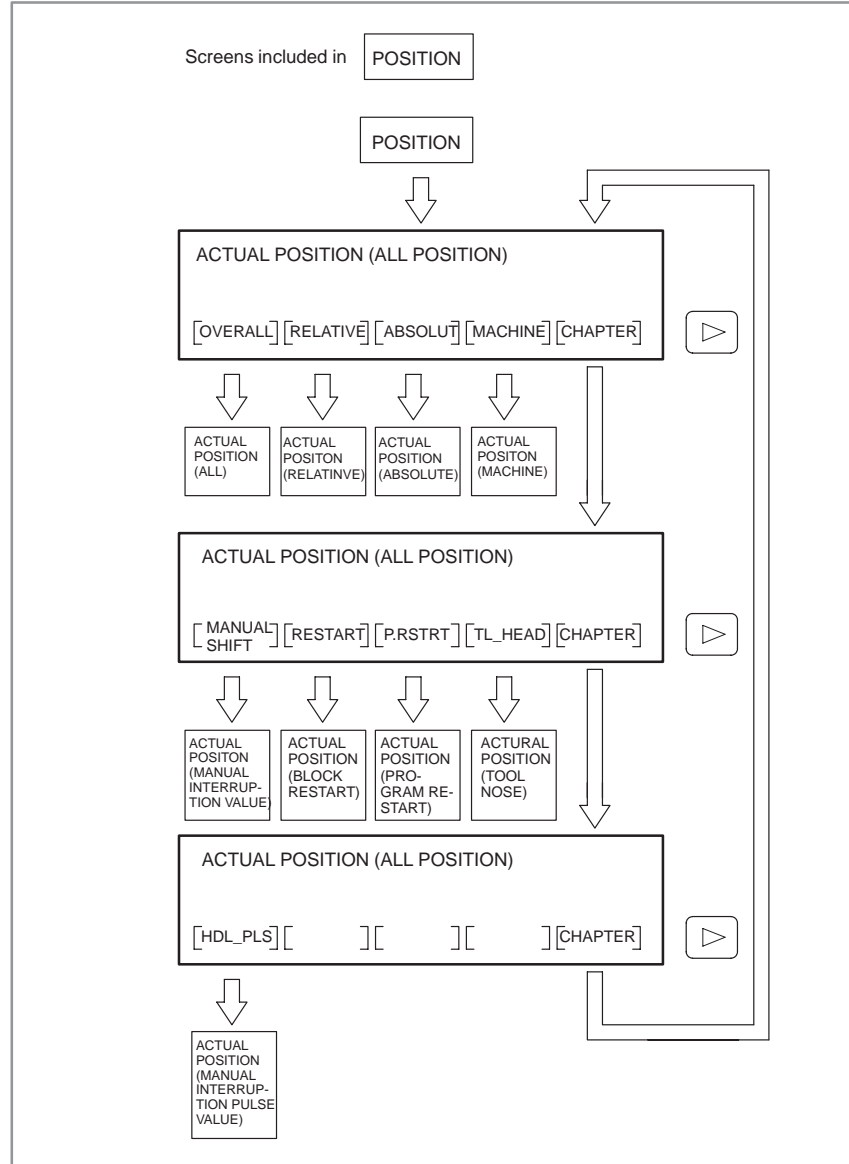

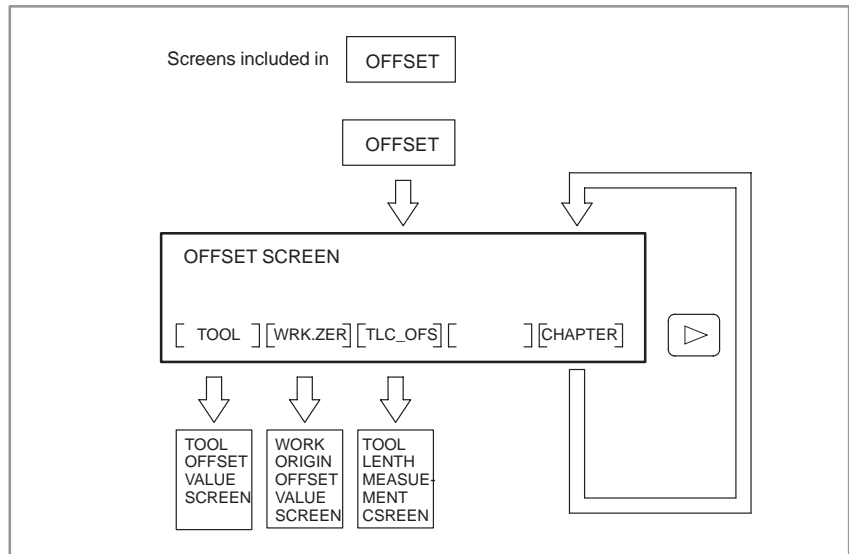
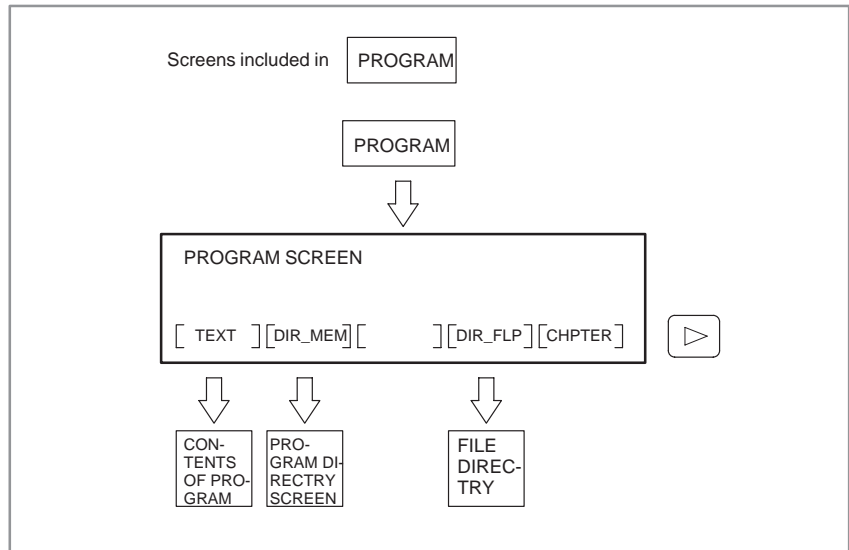

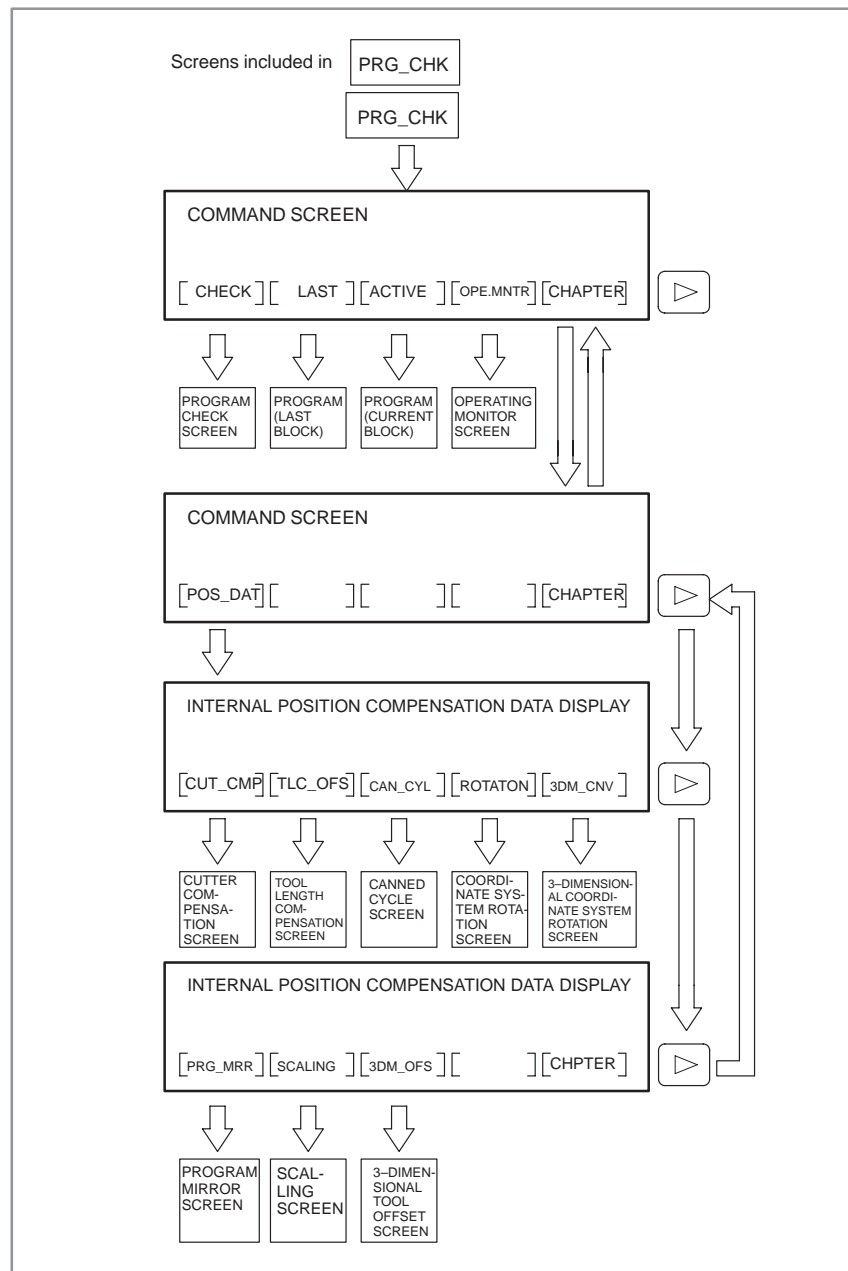

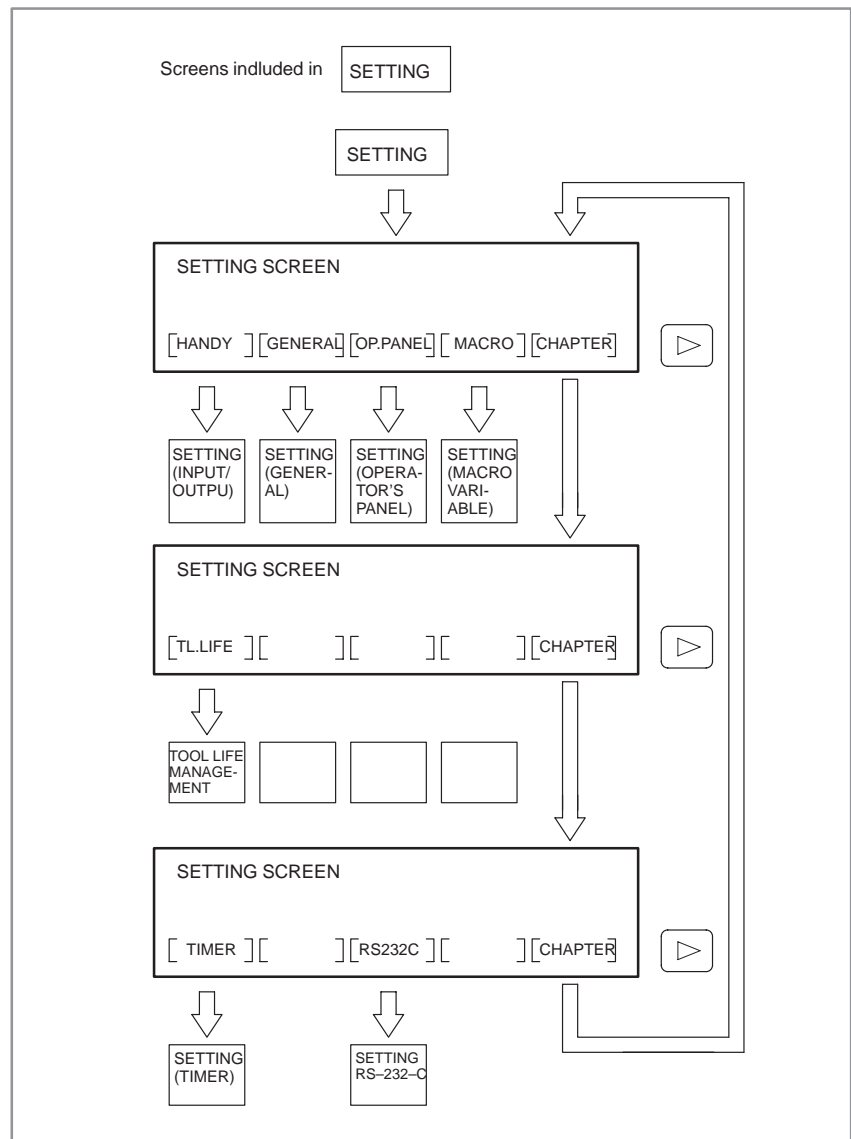

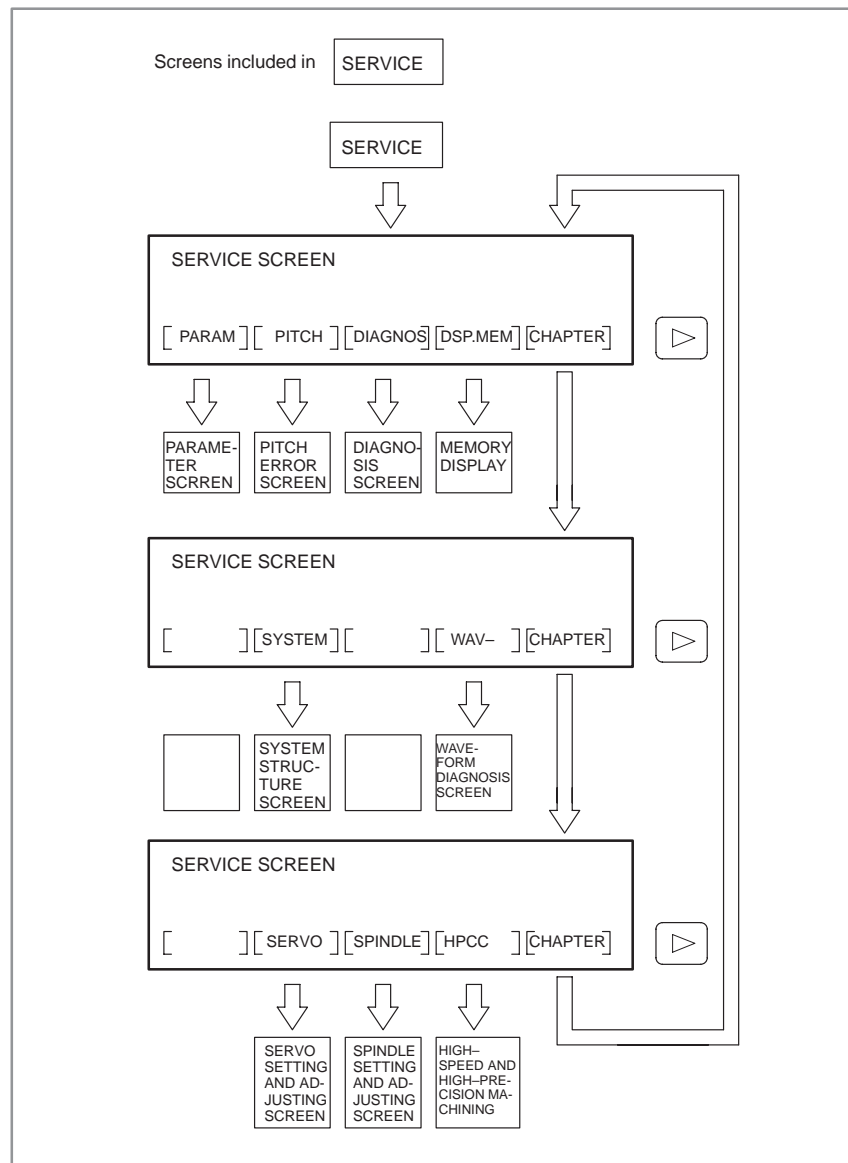

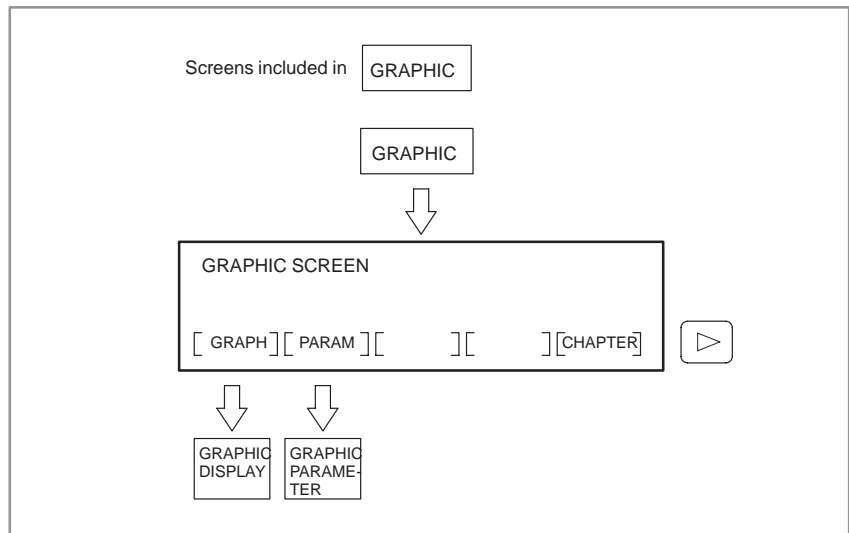
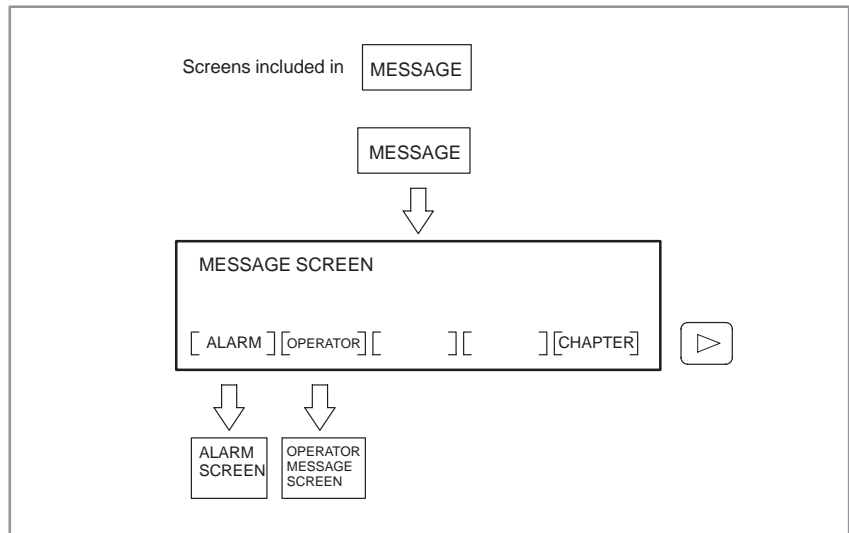

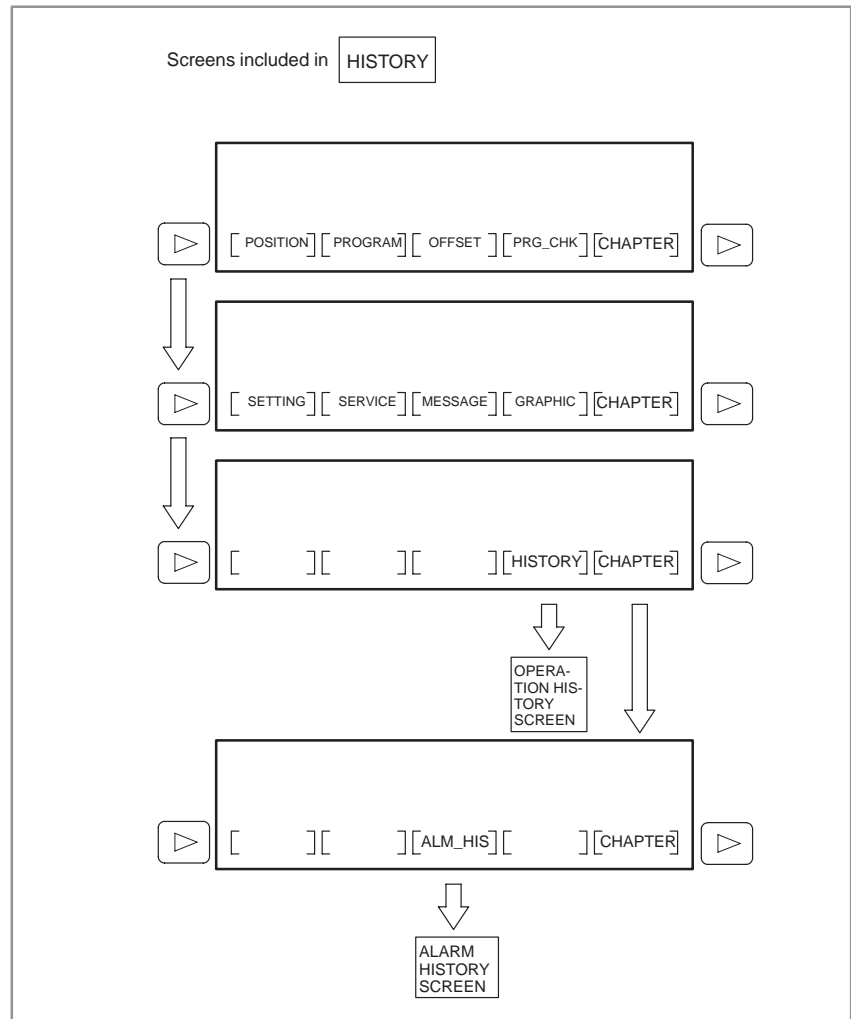





1.2 DISPLAYING SYSTEM CONFIGURATIONS

The software and hardware configuration of the CNC unit can be displayed on the CRT display. This feature allows you to easily obtain hardware or software information necessary, for example, when maintaining the CNC.

1.2.1 Displaying Method

- (1) Press the  key or [SERVICE] soft key to display screens such as parameter screens.
- (2) Press the [SYSTEM] soft key.
- (3) Press the page keys ( ) to switch the screen.

1.2.2 Software Information

```

SYSTEM CONFIG      (SOFTWARE)      01234 N12345

CNC SYSTEM ID     :  SERIES /  EDITION
F15M9A (1)      :  AAB1 (2) 0001 (3)

ASSEMBLY          EDITION          DRAM SIZE
BASIC (4)      0001 (5)      8MBYTE (6)
OPTION A1         0001
OPTION A2         0001
OPTION A3         0001          MACHINE NAME
OPTION A4         ----          ABCDEFGHIJ (7)
BASIC (SUB)      0001
OPTION S1        ----

MEM  *** STOP ***** *** ** 01 : 23 : 45 LSK
      SYSTEM                                CHAPTER+

```

- (1) CNC system ID
- (2) CNC control software series
- (3) CNC control software general edition
- (4) Assemblies providing CNC control software
- (5) Edition of each assembly
(A dash indicates that the assembly is not used.)
- (6) DRAM size of CNC
- (7) Machine name
(displayed only when set in parameter No.2390 to 2399)

```

SYSTEM CONFIG (SOFTWARE)      01234 N12345

SOFTWARE KIND : SERIES / EDITION
HELP MESSAGE (1) : AH00 (2) / 0001 (3)
SYSTEM BOOT : 6014 / 0005
DIGITAL SERVO : 9060 / 0005
SERIAL SPDL #1 : 9A20 / 0008
SERIAL SPDL #2 : 9A20 / 0008
PMC - NA : 4046 / 0005
GRAPHIC : 6001 / 0003
RMT BUF / DNC1 : 609A / 0004

MEM *** STOP ***** *** 01 : 23 : 45 LSK
SYSTEM CHAPTER+

```

- (1) Software type
- (2) Software series
- (3) Software edition

1.2.3 Slot Information

```

SYSTEM CONFIG (SLOT)      01234 N12345

SLOT      KIND              ID      SER./VER.
(1) 00:0 CNC CPU BOARD (2) (3) 1262:37 AAB1/0001 (4)
02:1 PMC CPU BOARD      2077:3D 4046/0005
03:3 CNC SUB CPU BOARD  F163:3A AAB1/0001
04:4 GRAPHIC            0145:40 600I/0003
84:6 REMOTE BUFFER      013F:3C 609A/0004

MEM *** STOP ***** *** 01 : 23 : 45 LSK
SYSTEM CHAPTER+

```

- (1) Slot number

XX : X

Physical slot number of FBUS 00 to 0F

(primary slots on the front)

Logical slot number

(slot number, logically assigned by CNC control software immediately after power-on)

- (2) Type of printed-circuit board

(3) ID number

XXXX : XX

Module ID XX3F : Remote buffer mode
 (See Section 2.6 for details.) XX45 : Graphic CPU board
 XX62 : Main CPU board (high-speed)
 XX63 : Additional axis/sub-CPU board
 XX6B : PMC-NB board
 XX6C : FAPT/IAP CPU board
 XX71 : Main CPU board (standard)
 XX74 : ROM cassette adapter
 XX77 : PMC-NA board

Software ID 37 : CNC CPU
 39 : NON CPU SUB
 3A : SUB CPU
 3C : RMT-BUF/DNC1
 3D : PMC-NA CPU
 40 : Graphic CPU
 41 : ROM cassette adapter
 42 : PMC-NB CPU
 44 : DNC1 #2
 45 : FAPT CPU
 4C : TC CPU
 4D : IAP CPU

(4) Series and edition of software (displayed only for modules featuring a CPU)

1.2.4 Module Information

SYSTEM CONFIG (SLOT)		O1234 N12345
(1)	<u>CMC MAIN CPU BOARD</u>	
	MODULE	Remark
(2)	<u>PROGRAM MEMORY (FROM)</u>	: 6MBYTE3.
	MAIN MEMORY (DRAM)	: 4MBYTE
	MAIN MEMORY (SRAM)	: TYPE A
	TAPE MEMORY (FILE)	: 512KBYTE
	PERIPHERAL MODULE	: _
	CHARACTER CONTROL	: 9"CRT
	SPINDLE CONTROL	: SERIAL,HI-DI
	SERVO CONTROL 1/2	: DIGITAL
	SERVO CONTROL 3/4	: DIGITAL
	MEM *** STOP **** *** **	01 : 23 : 45 LSK
	SYSTEM	CHAPTER+

(1) Name of printed-circuit board

Module information is displayed for the following printed-circuit boards (if mounted):

- | | |
|-------------------------------|----------------------------|
| 1 CNC main CPU board | 2 CNC sub-CPU board |
| 3 Additional axis board 1 | 4 Additional axis board 2 |
| 5 PMC-NA CPU board | 6 PMC-NB CPU board |
| 7 Graphic CPU board | 8 Remote buffer/DNC2 board |
| 9 DNC1 CPU board | 10 CAP/FAPT CPU board |
| 11 RISC CPU board | 12 MMC-II main CPU board |
| 13 MMC-II graphic CPU board | 14 MMC-III main CPU board |
| 15 Axis CPU board (multiaxis) | |

(2) Module name

The names of the modules mounted on the printed-circuit board, if any, are displayed.

(3) Module type

The type of each module is displayed if there are two or more types of a certain module, such as types having different capacities. A dash is displayed for those modules for which there is only a single type.

1.3 ALARM HISTORY DISPLAY

1.3.1 Display Method

- (1) Press the [HISTRY] soft key.
- (2) Press the [ALM_HIS] soft key. Then, the alarm history screen appears.
- (3) Other screens can be displayed by using the page keys

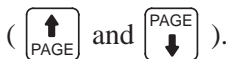

1.3.2 Alarm History Screen

```

ALARM HISTORY                                00000 N00001
SW000      PARAMETER ENABLE SWITCH ON
96/08/26   12:35:26
OT007 X +  OVERTRAVEL(HARD)
96/08/27   08:40:18
OT008 X -  OVERTRAVEL(HARD)
96/08/27   08:40:18
PW000      POWER MUST BE OFF
96/08/27   08:45:32
MC001
96/08/28   09:20:50

MDI *** STOP **** *** ***      00:00:00 ***
                                   CHAPTER
    
```

1.3.3 Display Format of History Data

History data items are displayed as follows:

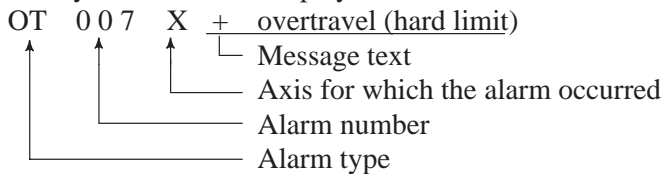

On the 14-inch CRT display, the date and time of alarm occurrence and alarm history data are displayed in this order on a line. On the 9-inch CRT display, the date and time of alarm occurrence is displayed over two lines under the alarm history data.

NOTE

- 1 No message text is displayed for EX and MC alarms.
- 2 When the values of parameter 1020 and 1021 are different from those when an alarm occurred, no correct axis data is not displayed.

1.3.4 Restrictions

- (1) The operation history function does not collect history data items while the OPERATION HISTORY screen is being displayed.
- (2) While the OPERATION HISTORY screen is being displayed, the operation history function does not collect history data items even when the OPERATION HISTORY screen is changed to the PMC screen. This is because it is still assumed that the OPERATION HISTORY screen is being displayed.
- (3) Approx. 2040 <MDI> key history data items can be recorded in memory as history data. When memory is full, older data items are deleted first.
- (4) Specify the correct date and time on the setting screen.
- (5) The number of signal addresses specified on the SELECT DI/DO screen affects the processing speed during automatic operation. Specify only the required signal addresses.

1.4 HELP FUNCTION

1.4.1 General

The help function displays detailed information about the alarm state of the CNC unit and soft key operations in a window on the CRT screen.

1.4.2 Operation

- **Displaying and clearing the help window**

While the CNC screen is displayed, press the **HELP** key (**SHIFT** + **EOB**) to display the help window. To clear the help window, press the **HELP** key again or select "9.CLOSE HELP WINDOW" from the help initial menu. (The help window cannot be called from the PMC screen, MMC screen, or conversational macro screen.)

- **Help initial menu**

To display the help initial menu, press the **HELP** key while no alarm is being issued.

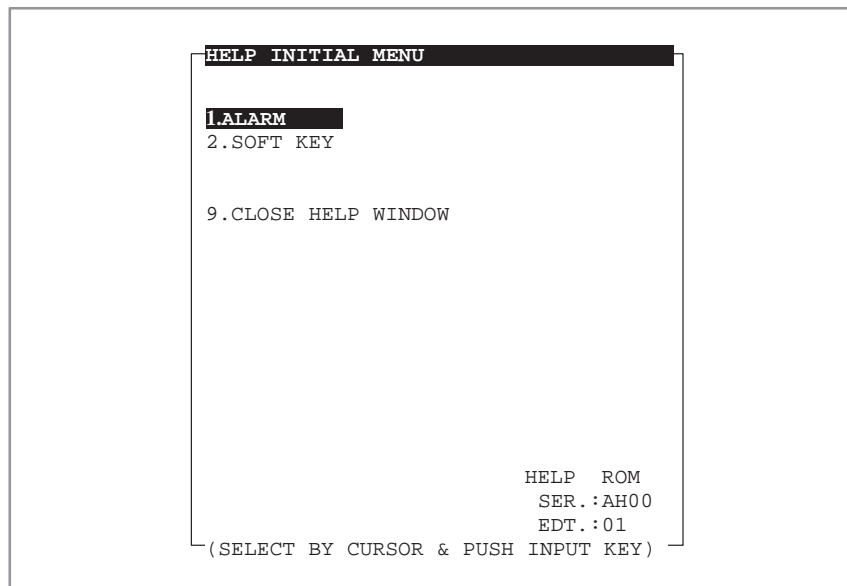

Fig. 1.4.2 (a) Initial help menu (14-inch CRT)

- Alarm help

Select "1.ALARM" from the help initial menu to display alarm help information (alarm selection/alarm details).

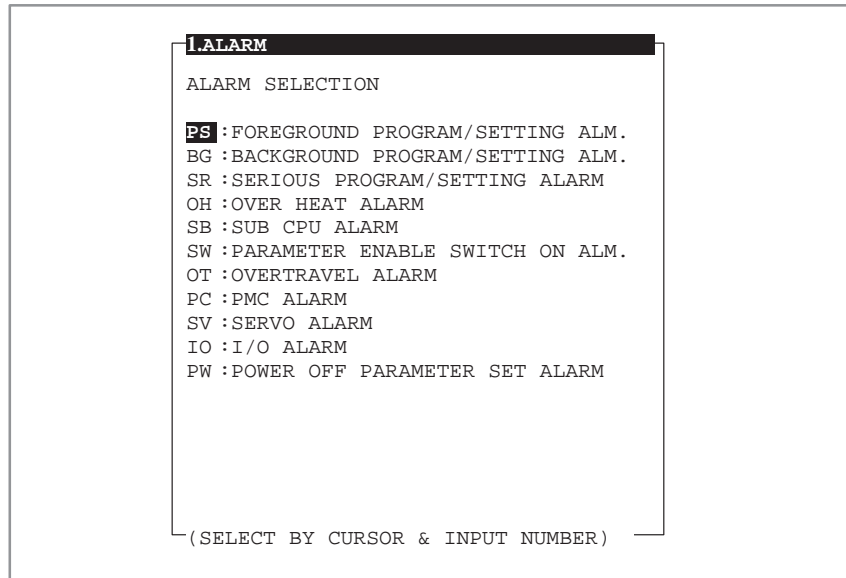

Fig. 1.4.2 (b) Sample alarm selection display (14-inch CRT)

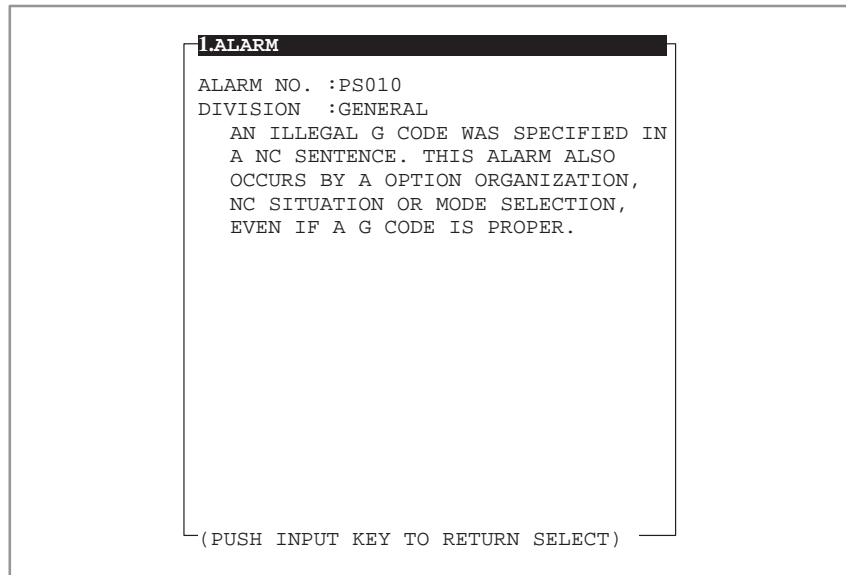

Fig. 1.4.2 (c) Sample detailed alarm display (14-inch CRT)

● **Soft key help**

Select “2.SOFT KEY” from the help initial menu to display soft key help information (soft key selection/soft key details).

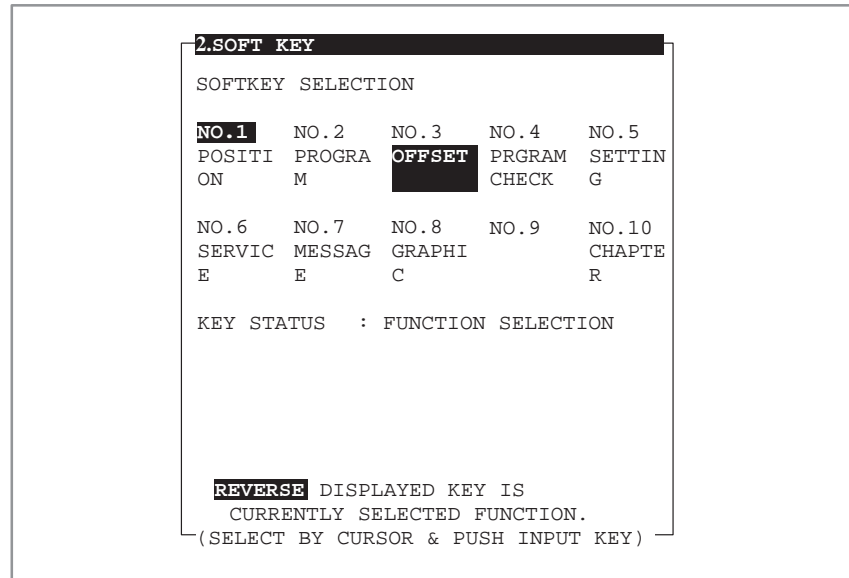

Fig. 1.4.2 (d) Sample soft key selection display (14-inch CRT)

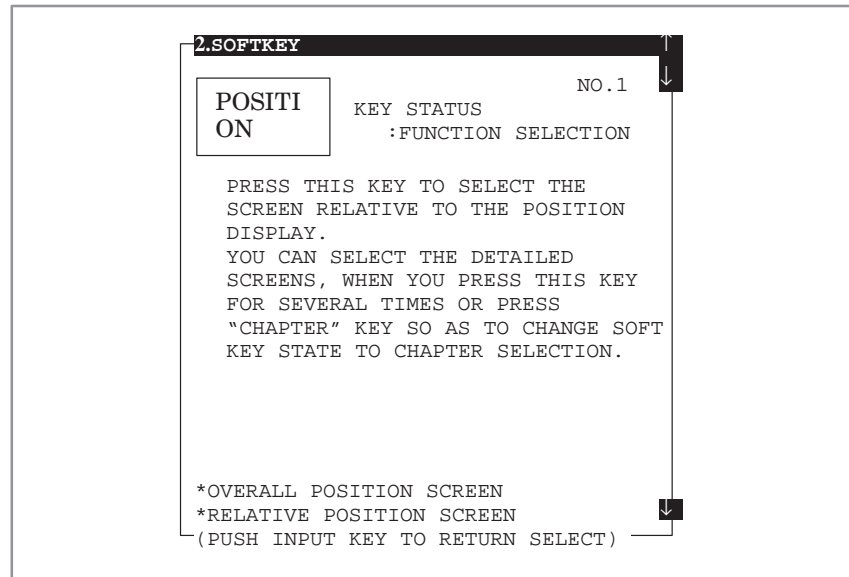



Fig. 1.4.2 (e) Sample detailed soft key display (14-inch CRT)

- **Using the help function in the alarm state**

Press the  key when the CNC is placed in the alarm state. Then, help information (alarm details/alarm list) relating to the currently issued alarm is displayed.

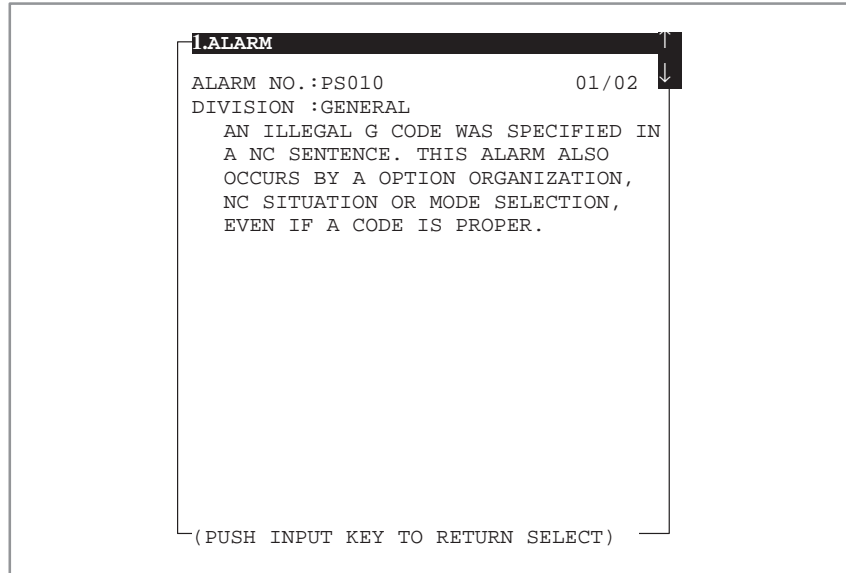

Fig. 1.4.2 (f) Sample detailed alarm display (14-inch CRT) in the alarm state

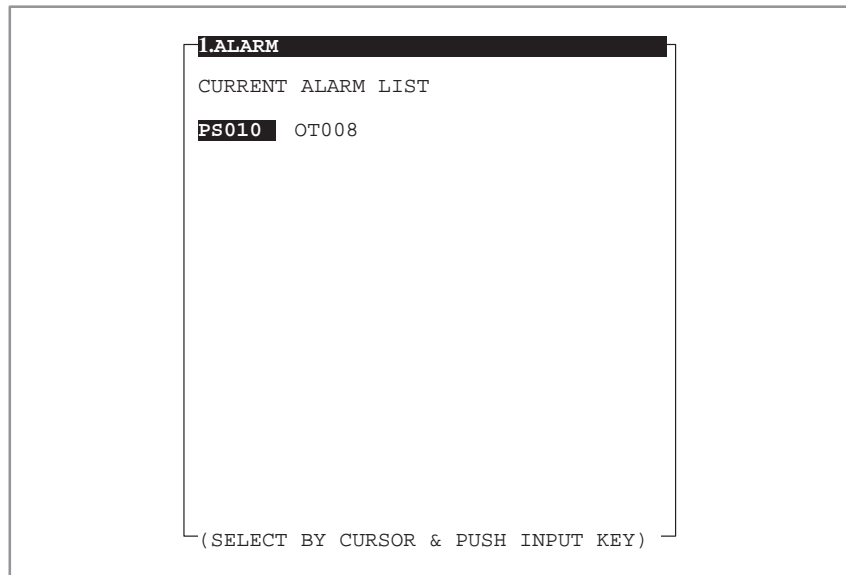



Fig. 1.4.2 (g) Sample alarm list display (14-inch CRT) in the alarm state

1.5 DIAGNOSIS FUNCTION

1.5.1 Displaying the Diagnosis Screen

- (1) Press the  key.
- (2) Press the [DIAGNOS] soft key. Then, the diagnosis screen is displayed.

1.5.2 Displaying the Status when it Appears that a Command is not being Executed

- **Displaying the status of the PMC interface signals**

The status of the interface signals (F and G) between the PMC and CNC can be displayed as the CNC internal status. The following table lists the correspondence between the numbers of this diagnostic data and address numbers (F000 and after and G000 and after) .

	Output from the CNC (G000 and after)	Input to the CNC (F000 and after)
For the BMI interface	Diagnostic numbers 0 and after	Diagnostic numbers 200 and after
For the FS3/6 interface	Diagnostic numbers 400 and after	Diagnostic numbers 500 and after

For example, data passed to the PMC through address G010 by the CNC is displayed as diagnostic data with number 10 (for the BMI interface) or number 410 (for the FS3/6 interface). For the interface signals, see Sec.4.5.

For details of each signal, refer to the corresponding interface connection manual.

● **Displaying the status when it appears that a command is not being executed**

Number	Bit	Display	Internal status when 1 is displayed
1000	0	INPOSITION CHECK	The position is being checked.
	1	FEED RATE OVERRIDE	The feedrate override is 0%.
	2	JOG FEED OVERRIDE	The jog feedrate override is 0%.
	3	INT./START LOCK ON	The start lock or interlock is on.
	4	SPEED ARRIVAL CHECK	The CNC is waiting for the speed-attained signal to be turned on.
	5	WAIT REVOLUTION	The CNC is waiting for the signal indicating that the spindle rotates once during threading.
	6	STOP POSITION CODER	The CNC is waiting for the position coder to rotate during spindle feed per rotation.
1001	7	BACKGROUND READING	The CNC is reading the tape in the foreground.
	0	BACKGROUND READING	The CNC is reading the tape in the background.

● **Displaying the start disable status**

The details of the start disable status are displayed.

If a bit is on, correct the error and start the machine.

When the operator starts the machine, the bit is cleared. Only one of the following bits is on at the same time. If there are two or more causes, only the bit corresponding to the last cause is on.

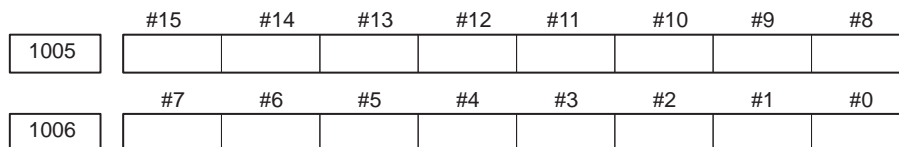

The bits indicate the following status when 1 is displayed for them:

- #0 The automatic operation stop signal (*SP) is low.
- #1 An alarm occurred.
- #2 The SRN or BRN signal is on.
- #3 An attempt was made to execute the same program in the background.
- #4 The device is not ready in the tape mode.
- #5 MDI execution data remains.
- #6 The tool retraction signal (TRES) is on. Alternatively, the machine is not at the position when the tool retraction signal was input.
- #7 The status does not permit the program to be executed in reverse.
- #8 The status of a DI or DO signal is invalid for a manual numerical command.(Note1)
- #9 The status of a DI or DO signal is invalid for repositioning.(Note2)

#10 Other than the above(Note3)

#11 Not used.

NOTE

- 1 The DO DEN or IPEN signal is high.
Constant surface speed control is being executed.
The status of the DI HEAD1/2 signal is invalid in the MDI mode. (Only for the Series 15-TT)
- 2 The DO OP signal is low for return operation.
The DI MLK signal is on.
The DO STL signal is on.
- 3 The system enters the start lock state during tracing.
A tool is being retracted in the hobbing machine.
On the bed grinder, an alarm is issued or the DI MLK signal is on.
The axis to be retracted in the jog mode is at a position at which starting is disabled.

● **Displaying the type of an alarm**

The type of the alarm issued is displayed.
When the alarm status is released, the corresponding bit is set to 0.

	#15	#14	#13	#12	#11	#10	#9	#8
1007								
	#7	#6	#5	#4	#3	#2	#1	#0
1008								

Each bit indicates an alarm type when 1 is displayed for the bit as follows:

- #0 Background P/S alarm
- #1 Foreground P/S alarm
- #2 Overheating
- #3 Sub-CPU error
- #4 Excessive synchronous error
- #5 Parameter writing switch on
- #6 Overtravel/external data input/output error
- #7 PMC error
- #8 External alarm message
- #9 Not used.
- #10 Serious P/S
- #11 Not used.
- #12 Servo alarm
- #13 I/O error
- #14 Input of a parameter requiring power disconnection
- #15 System error

● **Displaying the warning status**

The warning status is displayed.
When the warning status is released, the bit is set to 0.



A bit indicates the following status when 1 is displayed for it.

#0 The system is in the warning state.

#1 to #7 Not used.

● **Displaying the reset status**

The reset status and the status of input signals related to feed hold are displayed.



The bits indicate the following status when 1 is displayed for them:

ESP The emergency stop status is indicated.

RRW The reset and rewind signal is on.

ERS The external reset signal is on.

RST The reset key is pressed.

● **Displaying the details of a TH alarm**

The details of a TH alarm are displayed.

Number	Display	Description
1100	POSITION (CHARACTER) F	Location of the character for which a TH alarm is issued indicated as the number of characters from the beginning of the block (TH alarm in the foreground)
1101	BIT PATTERN (CHARACTER) F	Read code of the character for which a TH alarm is issued with a bit pattern (TH alarm in the foreground)
1110	POSITION (CHARACTER) B	Location of the character for which a TH alarm is issued indicated as the number of characters from the beginning of the block (TH alarm in the background)
1111	BIT PATTERN (CHARACTER) B	Read code of the character for which a TH alarm is issued with a bit pattern (TH alarm in the background)

● **Displaying position deviation**

The positional deviation of each axis is displayed.

Number	Display	Description
3000	X SERVO ERROR	Positional deviation along the X-axis in the detection unit
	Y SERVO ERROR	Positional deviation along the Y-axis in the detection unit
	Z SERVO ERROR	Positional deviation along the Z-axis in the detection unit
	:	
	:	

● **Displaying servo control information**

Servo control information is displayed.

3010 to 3023	Servo control information for axis 1
3030 to 3043	Servo control information for axis 2
3050 to 3063	Servo control information for axis 3
3070 to 3083	Servo control information for axis 4
3090 to 3103	Servo control information for axis 5
3110 to 3123	Servo control information for axis 6
3130 to 3143	Servo control information for axis 7
3150 to 3163	Servo control information for axis 8
3170 to 3183	Servo control information for axis 9
3190 to 3203	Servo control information for axis 10
3210 to 3223	Servo control information for axis 11
3230 to 3243	Servo control information for axis 12
3250 to 3263	Servo control information for axis 13
3270 to 3283	Servo control information for axis 14
3290 to 3303	Servo control information for axis 15

● **Checking a disconnection or overload alarm**

If a message indicating an overload alarm (SV 023) or disconnection alarm (SV 015) appears on the screen, check the diagnostic data to see if the data indicates an overload or disconnection alarm. The number of the diagnostic data is 3014 for axis 1, 3034 for axis 2, 3054 for axis 3, and the start number + 4 for other axes.

	#7	#6	#5	#4	#3	#2	#1	#0
3024	OVL	LVAL	OVC	HCAL	HVAL	DCAL	FBAL	OFAL

When an overload alarm is issued: #7 = 1

When a disconnection alarm is issued: #1 = 1

Then check the diagnostic data to determine the cause of the alarm. The number of the diagnostic data is 3015 for axis 1, 3035 for axis 2, 3055 for axis 3, and the start number + 5 for other axes.

Check bits 7 and 4 at the address to determine the cause of the alarm by consulting the following table.

	#7	#6	#5	#4	#3	#2	#1	#0
3025	ALDF			EXPC				

Cause of the alarm	7 bit ALDF	4 bit EXPC
Motor overheated	1	0
Amplifier overheated	0	0
Disconnected built-in pulse coder (hard)	1	0
Disconnected separate pulse coder (hard)	1	1
Disconnected pulse coder (soft)	0	0

Example

When a disconnection alarm (SV 015) is issued for axis 1, assume that the diagnostic data of Nos. 3014 and 3015 is as follows:

No. 3014: 00000010

No. 3015: 10110100

FBAL (bit 1) of diagnostic data No. 3014 is set to 1.

Both ALDF (bit 7) and EXPC (bit 4) of diagnostic data No. 3015 are set to 1. The diagnostic data indicates that the cause of the alarm is a disconnected separate pulse coder (hard).

Details of digital servo alarms

	#7	#6	#5	#4	#3	#2	#1	#0
3024	OVL	LVAL	OVC	HCAL	HVAL	DCAL	FBAL	OFAL

Symbol	Description
OFAL	LSI OVERFLOW An overflow alarm occurred in the digital servo.
FBAL	PULCO DISCONNECTION A disconnected pulse coder alarm occurred.
DCAL	EXCESS I FROM MOTOR A regenerative discharge circuit alarm occurred in the servo amplifier. (LED DC on the servo amplifier is on.)
HVAL	EXCESS V TO MOTOR An overvoltage alarm occurred in the servo amplifier. (LED HV on the servo amplifier is on.)
HCAL	ABNORMAL CURRENT IN SERVO An abnormal current alarm occurred in the servo amplifier. (LED HC on the servo amplifier is on.)
OVC	EXCESS CURRENT IN SERVO An overcurrent (overload) alarm occurred in the servo amplifier.
LVAL	POWER V TOO LOW An insufficient voltage alarm occurred in the servo amplifier. (LED LV on the servo amplifier is on.)
OVL	SV OVERLOAD An overload alarm occurred in the servo motor or amplifier. When this alarm occurs in the servo amplifier, the servo amplifier, separate discharge unit, or power transformer is overheated. (LED OH on the servo amplifier is on.)

● **Checking an absolute-position detection alarm**

If an alarm is detected at power-on when the absolute position is detected optionally, the message SV101 DATA ERROR (ABS PCDR) or OT032 NEED ZRN (ABS PCDR) appears. The cause of the alarm is indicated in the diagnostic data.

If the alarm message SV101 DATA ERROR (ABS PCDR) or OT032 NEED ZRN (ABS PCDR) appears on the screen, the cause of the alarm is indicated in the diagnostic data. The number of the diagnostic data is 3018 for axis 1, 3038 for axis 2, 3058 for axis 3, and the start number + 8 for other axes.

	#7	#6	#5	#4	#3	#2	#1	#0
3028	APMVAL	APPER	APFER	APTER	APCER	APBATZ	APPLSM	APNZRN

Symbol	Description (Action to be taken)
APNZRN	Absolute-position detection is not correlated with the reference position. (Action: Correlate absolute-position detection with the reference position.)
APPLSM	A pulse error alarm occurred. (Action: Correlate the absolute-position detection with the reference position.)
APBATZ	The voltage of the battery of the absolute pulse coder is 0. (Action: Replace the battery and correlate absolute-position detection with the reference position.)
APCER	A communication error occurred during data transmission. (Action: Replace the pulse coder.)
APTER	A time-out error occurred during data transmission. (Action: Replace the pulse coder.)
APFER	A framing error occurred during data transmission. (Action: Replace the pulse coder.)
APPER	A parity error occurred during data transmission. (Action: Replace the pulse coder.)
APMVAL	An excessive motor displacement alarm occurred. This alarm occurs if the machine moves by more than 24,000 pulses in the detection unit at power-on. (Action: Take appropriate action for the machine so that it does not move at power-on.)

Diagnosis No.	Description
4100	Amount of shift in the coordinate system by manual operation
4101	Amount of shift in the coordinate system by a manual interrupt using a function such as the simultaneous automatic/manual function
4102	Amount of offset in the coordinate system by workpiece coordinate system setting using the G92 command
4103	Amount of offset in the coordinate system by local coordinate system setting using the G52 command
4104	Amount of shift in the coordinate system in the machine lock state

- **Coordinate related data**

(1) Amount of shift in the coordinate system by manual operation

The amount of shift when the manual absolute signal based on manual operation along each axis is indicated.

Diagnosis No.	Display	Meaning of display data
4100	MANUAL SHIFT	Indicates the amount of shift in the coordinate system by manual operation along the X-axis. Indicates the amount of shift in the coordinate system by manual operation along the Y-axis. Indicates the amount of shift in the coordinate system by manual operation along the Z-axis.

(2) Amount of shift in the coordinate system by a manual interrupt using a function such as the simultaneous automatic/manual function

The amount of intervention by a manual interrupt along each axis is indicated.

Diagnosis No.	Display	Meaning of display data
4101	MANUAL SHIFT	Indicates the amount of manual interrupt using a function such as the simultaneous automatic/manual function along the X-axis. Indicates the amount of manual interrupt using a function such as the simultaneous automatic/manual function along the Y-axis. Indicates the amount of manual interrupt using a function such as the simultaneous automatic/manual function along the Z-axis.

(3) Amount of offset in the coordinate system by workpiece coordinate system setting using the G92 command

The amount of offset in the coordinate system with the G92 command along each axis is indicated.

Diagnosis No.	Display	Meaning of display data
4102	G92 OFFSET	Indicates, in input units, the amount of offset using the G92 command along the X-axis. Indicates, in input units, the amount of offset using the G92 command along the Y-axis. Indicates, in input units, the amount of offset using the G92 command along the Z-axis.

- (4) Amount of offset in the coordinate system by local coordinate system setting using the G52 command

The amount of offset in the coordinate system with the G52 command along each axis is indicated.

Diagnosis No.	Display	Meaning of display data
4103	G52 OFFSET	Indicates, in input units, the amount of offset using the G52 command along the X-axis. Indicates, in input units, the amount of offset using the G52 command along the Y-axis. Indicates, in input units, the amount of offset using the G52 command along the Z-axis.

- (5) Amount of shift in the coordinate system in the machine lock state

The amount of shift along each axis in the coordinate system by using a move command in the machine lock state is indicated.

Diagnosis No.	Display	Meaning of display data
4104	MCN LOCK SHIFT	Indicates, in input units, the amount of shift in the machine lock state along the X-axis. Indicates, in input units, the amount of shift in the machine lock state along the Y-axis. Indicates, in input units, the amount of shift in the machine lock state along the Z-axis.

1.6 NC STATUS DISPLAY

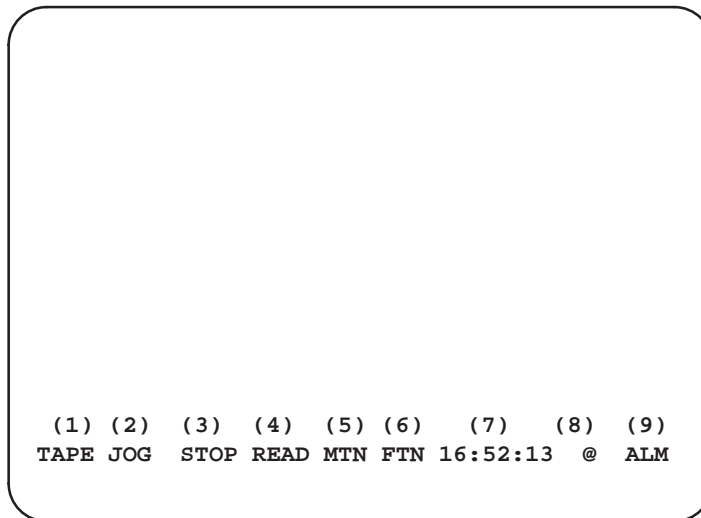

- (1) Automatic operation mode selection
(MEM, MDI, TAPE, EDIT, or *****)

This field displays the automatic operation mode currently selected.
When no automatic operation mode is selected, **** is displayed.

- (2) Manual operation mode selection
(JOG, HND, INC, AGJ, J+REF, or ***)

This field displays the manual operation mode currently selected.
When no manual operation mode is selected, **** is displayed.

- (3) Automatic operation status
(RESET, STOP, HOLD, STRT, MSTR, or SRCH)

This field displays the status of automatic operation.

RSET : Reset is in progress.
STOP : Automatic operation is stopped.
HOLD : Automatic operation is suspended.
STRT : Automatic operation is started.
MSTR : Execution of a manual numeric command is started.
NSRC : Sequence number search is in progress.

- (4) Program editing status
(READ, PNCH, VRFY, SRCH, COND, EDIT, or *****)

This field displays the status of program editing.

READ : Registration is in progress.
PNCH : Punch-out is in progress.
VRFY : Verification is in progress.
SRCH : Search is in progress.
COND : Memory arrangement is in progress.
EDIT : An editing operation (such as insertion or alteration) is in progress.
**** : No editing operation is in progress,

- (5) Axis movement/dwell status (MTN, DWL, or ***)

This field displays MTN during movement along an axis, and displays DWL when the machine is dwelling. This field displays *** in other cases.

(6) M/S/T/B function status (FIN or ***)

This field displays FIN when a miscellaneous function such as M, S, T, and B is being performed (that is, when the system is waiting for a completion signal from the PMC). In other cases, this field displays ***.

(5) (6) Emergency stop status (EMG)

If an emergency stop occurs, the display of (5) and (6) disappears and the character string —EMG— is displayed in reverse, instead.

(7) Current time display

This field displays the current time in hours, minutes, and seconds.

Example)

16:52:13 (Fifty-two minutes and thirteen seconds after four o'clock in the afternoon)

(8) Status of writing into nonvolatile memory (@ or space)

This field displays @ when data is being written into nonvolatile memory.

(9) Alarm status and label skip status (ALM, BAT, WRN, LSK, or ***)

ALM blinks in reverse when an alarm has occurred.

WRN blinks when a warning message appears on the CRT screen.

This field displays BAT when the voltage of the battery for the absolute-position detector or nonvolatile memory for storing parameters, tool compensation data, and part programs is low. This display disappears after the battery is replaced and the alarm is reset.

This field displays LSK when none of these statuses are present, and the tape reader is placed in the label skip status. In other cases, this field displays ***.

1.7 WAVEFORM DIAGNOSIS FUNCTION

1.7.1 Display of Wave Diagnosis (Graph) Screen

- (1) Press the [SERVICE] soft key or  key.
- (2) Press the [WAVE DIAGNS] soft key. Then, the WAVE DIAGNOSIS (GRAPH) screen is displayed.

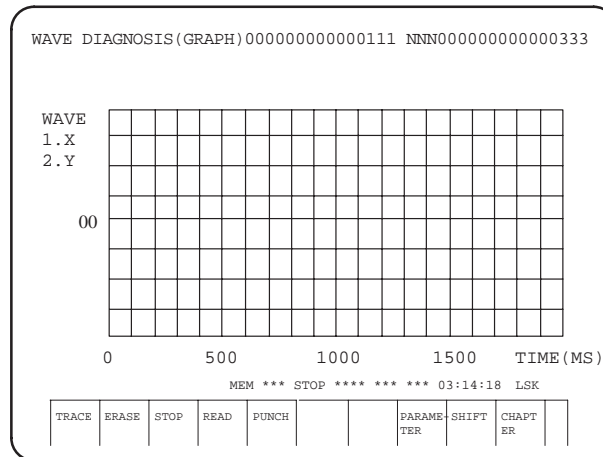

1.7.2 Setting the Waveform Diagnosis Parameters

- While the WAVE DIAGNOSIS (GRAPH) screen is displayed, press the [PARAMETER] soft key. Then, the WAVE DIAGNOSIS (PARAMETER) screen is displayed.

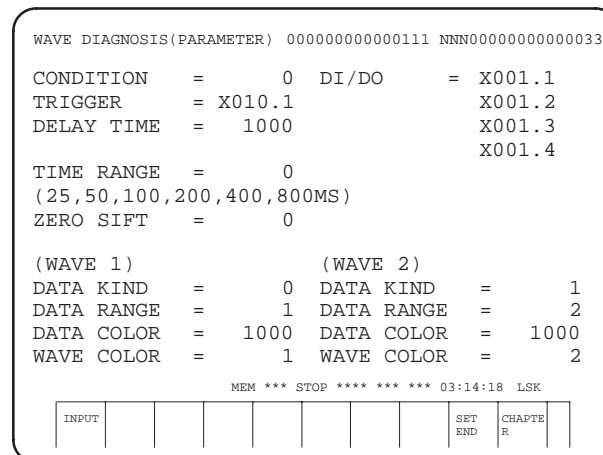

(1) One-shot type waveform diagnosis

The collection of data is started according to a set start condition, and data changes are displayed graphically.

(a) CONDITION

Enter one of the following settings in the CONDITION field on the WAVE DIAGNOSIS (PARAMETER) screen.

- 0 : Starts sampling data the moment the [TRACE] key is pressed.
- 1 : Starts sampling data when the trigger signal rises after the [TRACE] key is pressed.
- 2 : Starts sampling data when the trigger signal falls after the [TRACE] key is pressed.

NOTE

When no trigger signal is specified, 1 and 2 are assumed to be 0.

(b) TRIGGER

Enter the PMC address and bit number corresponding to a trigger signal in the TRIGGER field on the WAVE DIAGNOSIS (PARAMETER) screen.

Valid data range : G000.0 to G511.7, F000.0 to F319.7,
Y000.0 to Y127.7, and X000.0 to X127.7

(c) TIME RANGE

Enter 25, 50, 100, 200, 400, or 800 in the TIME RANGE field on the WAVE DIAGNOSIS (PARAMETER) screen. The sampling time is specified as 0.5, 1.0, 2.0, 4.0, 8.0, or 16.0 s.

The sampling time determines not only sampling conditions, but also graph display conditions.

(d) DATA KIND

Select the type of waveform to be traced and enter your choice in the DATA TYPE field on the WAVE DIAGNOSIS (PARAMETER) screen.

- 0 : Servo error (pulses, detection units)
- 1 : Number of servo pulses to be generated (pulses, command units)
- 2 : Servo torque (%)
- 5 : Actual speed (pulses, detection units)
- 6 : Value of the electric current command for the servo (%)
- 7 : Data during heat simulation (%)
- 9 : Composite speed for all axes (mm/min or rpm)
- 10: Spindle speed (rpm)
- 11: Load meter for a spindle (%)

NOTE

The servo torque and the value of the electric current command are represented as percentages of the corresponding settings in parameter 1979. Spindle speed refers to the speed of a digital spindle only.

(e) AXIS ASSIGN

Enter one of the following settings in the AXIS ASSIGN field on the WAVE DIAGNOSIS (PARAMETER) screen.

[When 1 to 7 is specified as the waveform type]

1 to (the number of controlled axes): Servo axis number

[When 9 is specified as the waveform type]

1 or 2: For the Series 15-MB/15-TB, specify 1 only. For the Series 15-TTB, specify 1 on the head 1 side, and specify 2 on the head 2 side.

[When 10 or 11 is specified as the waveform type]

1 or 2: Spindle amplifier number

(f) DI/DO

Enter the PMC address and bit number of the external input/output signal to be traced in the DI/DO field on the WAVE DIAGNOSIS (PARAMETER) screen.

Valid data range : G000.0 to G511.7, F000.0 to F319.7,
Y000.0 to Y127.7, and X000.0 to X127.7

(g) DATA RANGE

Enter the value per graduation on the vertical axis of the graph (0 to 524287) in the DATA RANGE field on the WAVE DIAGNOSIS (PARAMETER) screen.

(h) ZERO SHIFT

Enter the value for the zero point (-10000 to +10000) in the ZERO SHIFT field on the WAVE DIAGNOSIS (PARAMETER) screen.

(i) WAVE COLOR

Enter one of the following settings in the WAVE COLOR field on the WAVE DIAGNOSIS (PARAMETER) screen.

1: Red, 2: Green, 3: Yellow, 4: Blue, 5: Purple, 6: Light blue, 7: White

(2) Waveform diagnosis of servo-alarm type

(a) CONDITION

Enter one of the following settings in the CONDITION field on the WAVE DIAGNOSIS (PARAMETER) screen.

100 : Starts sampling data and fetching it into the ring buffer the moment the [TRACE] key is pressed and terminates the sampling when a servo alarm occurs.

101 : Starts sampling data and fetching it into the ring buffer the moment the [TRACE] key is pressed and terminates the sampling when a servo alarm occurs or when the trigger signal rises.

102 : Starts sampling data and fetching it into the ring buffer the moment the [TRACE] key is pressed and terminates the sampling when a servo alarm occurs or when the trigger signal falls.

(b) TRIGGER

Enter the PMC address and bit number corresponding to the trigger signal specified in the TRIGGER field on the WAVE DIAGNOSIS (PARAMETER) screen.

Valid data range : G000.0 to G511.7, F000.0 to F319.7,
Y000.0 to Y127.7, and X000.0 to X127.7

(c) DELAY TIME

Enter the time (0 to 32000 ms) in the DELAY TIME field on the WAVE DIAGNOSIS (PARAMETER) screen. This setting specifies how long actual termination of tracing is delayed since the tracing termination condition is satisfied.

(d) DATA KIND

Select the types of waveforms to be traced from the following and enter the settings in parameters 4640, 4641, 4645, and 4646 on the WAVE DIAGNOSIS (PARAMETER) screen.

For details, see the later description of parameters.

- 0 : Servo error (pulses, detection units)
- 1 : Number of servo pulses to be generated (pulse,command units)
- 2 : Servo torque (%)
- 5 : Actual speed (pulses, detection units)
- 6 : Value of the electric current command for the servo (pulses, detection units)
- 7 : Data during heat simulation (%)

NOTE

The servo torque and the value of the electric current command are represented as percentages of the corresponding settings in parameter 1979.

(e) AXIS ASSIGN

Enter one of the following settings in the AXIS ASSIGN field on the WAVE DIAGNOSIS (PARAMETER) screen.

1 to (the number of controlled axes): Servo axis number

(f) DATA RANGE

Enter the value per graduation on the vertical axis of the graph (0 to 524287) in the DATA RANGE field on the WAVE DIAGNOSIS (PARAMETER) screen.

(g) ZERO SHIFT

Enter the value for the zero point (-10000 to +10000) in the ZERO SHIFT field on the WAVE DIAGNOSIS (PARAMETER) screen.

(h) WAVE COLOR

Enter one of the following settings in the WAVE COLOR field on the WAVE DIAGNOSIS (PARAMETER) screen.

1: Red, 2: Green, 3: Yellow, 4: Blue, 5: Purple, 6: Light blue, 7: White

1.7.3 Starting or Terminating Data Sampling

- (1) Starting data sampling
Press the [TRACE] key. The system enters the sampling-enabled state (trace mode).
- (2) Terminating data sampling
Press the [STOP] key. When data is being sampled, data sampling is terminated.

1.7.4 Waveform Display

As soon as data is sampled, it is displayed in the form of a graph on the WAVE DIAGNOSIS (GRAPH) screen. For servo-alarm types, the date and time at the end of data sampling are displayed at the top of the screen.

1.7.5 Editing a Displayed Waveform

The waveform representing the sampled data can be edited using the following operations to make it easier to view.

- (1) Specifying the waveform type (only for the servo-alarm type)
To display data items sampled with the servo-alarm waveform diagnosis function, specify the waveform type specified in parameters 4640 and 4641 as the type of the 1st waveform and the waveform type specified in parameters 4645 and 4646 as the type of the 2nd waveform.
- (2) Specifying the display range of the vertical axis
To enlarge or reduce the display range of the vertical axis, enter a value per graduation in the DATA RANGE field on the WAVE DIAGNOSIS (PARAMETER) screen.
- (3) Specifying the display range of the horizontal axis
To enlarge or reduce the display range of the horizontal axis, enter a time per graduation in the TIME RANGE field on the WAVE DIAGNOSIS (PARAMETER) screen.
- (4) Specifying the value of the zero point
To move the display range for the vertical axis up or down, enter the desired value of the zero point in the ZERO SHIFT field on the WAVE DIAGNOSIS (PARAMETER) screen.
- (5) Moving the zero point
press the [SHIFT] key on the WAVE DIAGNOSIS (PARAMETER) screen. The WAVE DIAGNOSIS (GRAPH) screen is displayed. To move the position of the zero point in the graph up and down, press the [WAVE 1 ↑], [WAVE 1 ↓], [WAVE 2 ↑], and [WAVE 2 ↓] keys on the screen.

1.7.6 Erasing a Displayed Waveform

To erase the waveform being displayed, press the [ERASE] key on the WAVE DIAGNOSIS (PARAMETER) screen. Once a waveform is erased, it cannot be displayed again.

1.8 OPERATING MONITOR SCREEN

1.8.1 Display Method

1. Press the <PRG-CHK> soft key or  key.
2. Press the <OPE.MNTR> key.

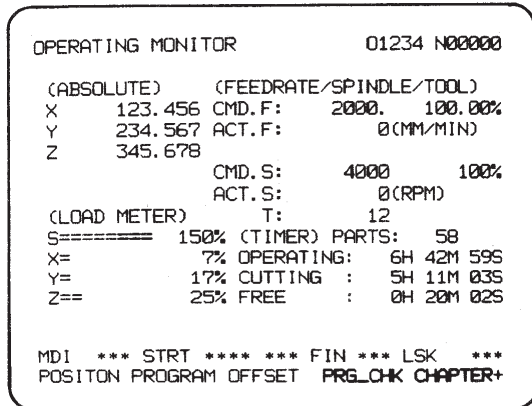

NOTE

- 1 Set the numbers of the axes whose load is to be displayed in parameter Nos. 2231 to 2333. Set the rated load of the motor corresponding to each load meter in parameter Nos. 2234 to 2237. When the applied load reaches the rated load, the load meter indicates 100%.
- 2 Load meter data is displayed using a bar graph and percentages. The range of the bar graph is 0% to 200%. 100% is indicated by a change in color on the 14" screen or a change in brightness on the 9" CRT screen.
- 3 The 14" CRT screen displays a graph indicating the fluctuations in load over one minute. One screen displays the fluctuations for one load meter. The cursor keys <↑> and <↓> can be used to select the load meter for which this type of graph is to be displayed.

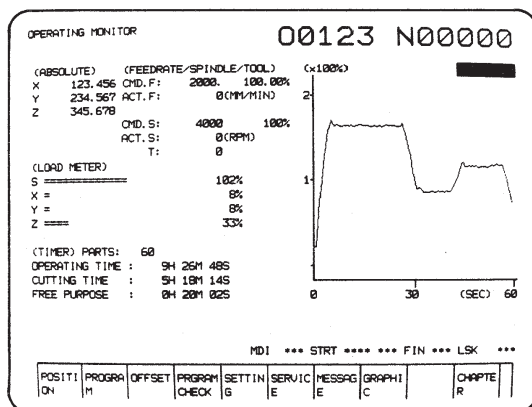

1.9 INTERNAL POSITION COMPENSATION DATA DISPLAY FUNCTION

The function for displaying internal position compensation data displays the data used in the CNC for each function while the following functions are executed:

- Cutter compensation
- Tool length compensation
- Drilling canned cycle
- Coordinate rotation
- Three-dimensional coordinate conversion
- Programmable mirror image
- Scaling
- Three-dimensional tool compensation

1.9.1 Display Method

- (1) Press the [PRG_CHK] soft key or the [P-CHECK] key on the MDI panel.
- (2) Press the [POS_DAT] soft key. Then, the internal position compensation data display screen is displayed.

1.9.2 Display Data

- Cutter compensation screen

POSITION DATA										O0100 N00000		
CUTTER COMPENSATION		(RELATIVE)		(DIST TO GO)								
ON/OFF												
		X	0.000	X	0.000							
		Y	0.000	Y	0.000							
OFFSET VECTOR		Z	0.000	Z	0.000							
		U	0.000	U	0.000							
X	100.000	V	0.000	V	0.000							
Y	200.000	W	0.000	W	0.000							
		(G/D/H) (M) (T)										
		G91	G54	M02								
		G01	G80									
		G17	G64									
		G41	G49	(L):	0							
		D	0	H	0							
		(F)	0	(ACT.F)	0							
		(S)		(ACT.S)	0							
MDI***STOP*** ** ** 02:47:55 LSK												
CUTTER CMPNS	TL LEN OFFSET	CANNED CYCLE	ROTATI ON	3-DIM CNVSON	PRGMBL MIRROR	SCALIN G	3-DIM OFFSET	CHAPT ER				

[ON/OFF]

Displays ON in the cutter compensation mode and OFF in other modes.

[OFFSET VECTOR]

Displays the cutter compensation vector created for each block.

● **Tool length compensation screen**

POSITION DATA										O0100 N00000	
CUTTER COMPENSATION					(RELATIVE)		(DIST TO GO)				
ON/OFF					X	0.000	X	0.000			
OFFSET VECTOR					Y	0.000	Y	0.000			
					Z	0.000	Z	0.000			
					U	0.000	U	0.000			
X	100.000			V	0.000	V	0.000				
Y	200.000			W	0.000	W	0.000				
Z	300.000			(G/D/H) (M) (T)							
U	0.000			G91	G54	M02					
V	0.000			G01	G80						
W	0.000			G17	G64						
					G40	G43	(L):	0			
					D	0 H 0					
					(F)	0 (ACT.F)		0			
					(S)	(ACT.S)		0			
MDI***STOP*** **/ **/ 02:47:55 LSK											
CUTTER CMPENS	TL LEN OFFSET	CANNED CYCLE	ROTATI ON	3-DIM CNVSON	PRGMBL MIRROR	SCALIN G	3-DIM OFFSET		CHAPT ER		

[ON/OFF]

Displays ON in the tool length compensation mode and OFF in other modes.

[OFFSET VECTOR]

Displays the tool length compensation vector created for each block. Remark)

Tool length compensation can be applied for any axis according to parameter setting and therefore data for all axes are displayed.

● **Canned cycle screen**

POSITION DATA										O0100 N00000	
CANNED CYCLE					(RELATIVE)		(DIST TO GO)				
ON/OFF					X	0.000	X	0.000			
INITIAL POINT					Y	0.000	Y	0.000			
NUMBER OF REPETITIONS					Z	0.000	Z	0.000			
					U	0.000	U	0.000			
Z	0.000	L(CMD)	20	V	0.000	V	0.000				
					L(ACT)	1	W	0.000	W	0.000	
POINT R					(G/D/H) (M) (T)						
CUT-IN VALUE					G91	G54	M02				
Z	-200.000			G01	G76						
POINT Z					G17	G64					
SHIFT VALUE					G40	G49	(L):	0			
Z	-200.000			D	0 H 0						
					X	10.000	(F)	0 (ACT.F)	0		
					Y	20.000	(S)	(ACT.S)	0		
MDI***STOP*** **/ **/ 02:47:55 LSK											
CUTTER CMPENS	TL LEN OFFSET	CANNED CYCLE	ROTATI ON	3-DIM CNVSON	PRGMBL MIRROR	SCALIN G	3-DIM OFFSET		CHAPT ER		

[ON/OFF]

Displays ON in the drilling canned cycle mode and OFF in other modes.

[INITIAL POINT]

Displays the absolute position of the initial point.

[POINT R]

Displays the absolute position of point R.

[POINT Z]

Displays the absolute position of point Z.

[NUMBER OF REPETITIONS]

Displays the specified value and current value of the number of repetitions.

[CUT IN VALUE]

Displays the depth of cut for G73 and G83.

[SHIFT VALUE]

Displays the shift for G76 and G87.

- Coordinate rotation screen

POSITION DATA										O0100 N00000	
COORDINATE SYSTEM ROTATION (RELATIVE) (DIST TO GO)											
ON/OFF											
ROTATION CENTER											
X	100.000									X	0.000
Y	200.000									Y	0.000
										Z	0.000
										U	0.000
										V	0.000
										W	0.000
ANGLE OF ROTATION											
90.00000											
G91 G54 M02											
G01 G80											
G17 G64											
G40 G49 (L): 0											
D 0 H 0											
(F) 0 (ACT.F) 0											
(S) (ACT.S) 0											
MDI***STOP*** /* /* 02:47:55 LSK											
CUTTER	TL LEN	CANNED	ROTATI	3-DIM	PRGMBL	SCALIN	3-DIM		CHAPT		
CMPEMS	OFFSET	CYCLE	ON	CONVSON	MIRROR	G	OFFSET		ER		

[ON/OFF]

Displays ON in the coordinate rotation mod and OFF in other modes.

[ROTATION CENTER]

Displays the absolute position of the center of coordinate rotation.

[ANGLE OF ROTATION]

Displays the angle of coordinate rotation.

- Three-dimensional coordinate conversion screen

POSITION DATA										O0100 N00000	
3-DIMENSIONAL COORDINATE CONVERSION (RELATIVE) (DIST TO GO)											
ON/OFF											
ROTATION CENTER											
(FIRST)					(SECOND)						
X	1.000	X	-1.000							U	0.000
Y	2.000	Y	-2.000							V	0.000
Z	3.000	Z	-3.000							W	0.000
DIRECTION OF CENTER AXIS OF POTATION											
(FIRST)					(SECOND)						
X	1.000	X	-1.000							G91 G54 M02	
Y	2.000	Y	-2.000							G01 G80	
Z	3.000	Z	-3.000							G17 G64	
ROTATION ANGLE											
(FIRST)					(SECOND)						
30.00000					-30.00000						
(F) 0 (ACT.F) 0											
(S) (ACT.S) 0											
MDI***STOP*** /* /* 02:47:55 LSK											
CUTTER	TL LEN	CANNED	ROTATI	3-DIM	PRGMBL	SCALIN	3-DIM		CHAPT		
CMPEMS	OFFSET	CYCLE	ON	CONVSON	MIRROR	G	OFFSET		ER		

[ON/OFF]

Displays ON in the three-dimensional coordinate conversion mode and OFF in other modes.

[ROTATION CENTER]

Displays the absolute position of the rotation center for three-dimensional coordinate conversion.

[DIRECTION OF CENTER AXIS OF ROTATION]

Displays the direction of the rotation center axis for three-dimensional coordinate conversion

[ROTATION ANGLE]

Displays the rotation angle for three-dimensional coordinate conversion.

● Programmable mirror image screen

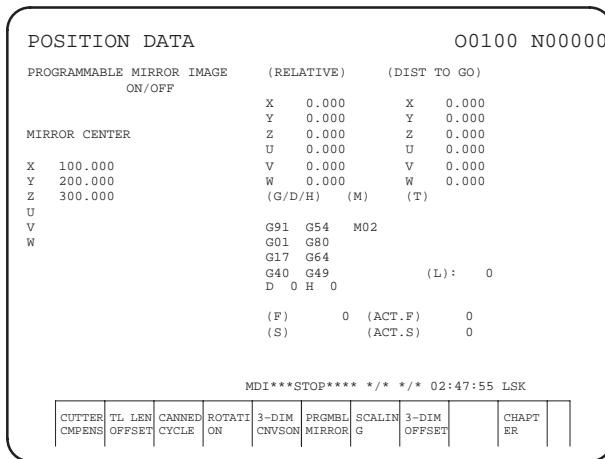

[ON/OFF]

Displays ON in the programmable mirror image mode and OFF in other modes.

[MIRROR CENTER]

Displays the absolute position of the mirror axis.

Remark)

Nothing is displayed for axes along which no mirror axis exists. When 0 is displayed, it means that the mirror axis exists at coordinate 0.

● Scaling screen

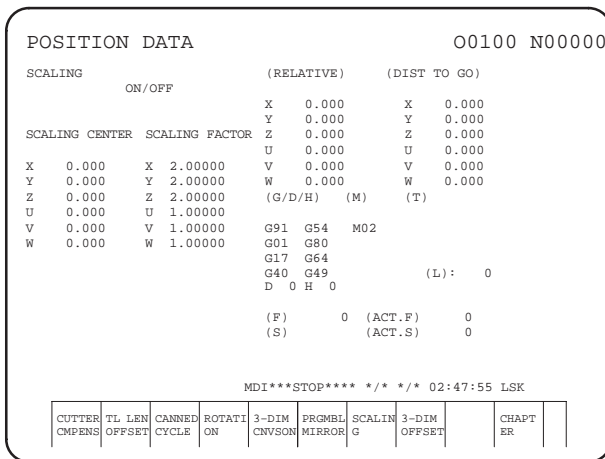

[ON/OFF]

Displays ON in the scaling mode and OFF in other modes.

[SCALING CENTER]

Displays the absolute position of the scaling center.

[SCALE FACTOR]

Displays the scale factor for each axis.

- **Three-dimensional tool compensation screen**

POSITION DATA										O0100 N00000	
THREE-DIMENSIONAL TOOL OFFSET (RELATIVE) (DIST TO GO)											
ON/OFF											
OFFSET VECTOR											
X	1.000	Y	2.000	Z	3.000	X	0.000	Y	0.000	Z	0.000
						U	0.000	U	0.000	V	0.000
						W	0.000	W	0.000	(G/D/H)	(M)
						(T)					
G91 G54 M02											
G01 G80											
G17 G64											
G41 G49										(L): 0	
D 0 H 0											
(F) 0 (ACT.F) 0											
(S) (ACT.S) 0											
MDI***STOP*** **/* 02:47:55 LSK											
CUTTER CMPENS	TL LEN OFFSET	CANNED CYCLE	ROTATI ON	3-DIM CNVSON	PRGMBL MIRROR	SCALIN G	3-DIM OFFSET	CHAPT ER			

[ON/OFF]

Displays ON in the three-dimensional tool compensation mode and OFF in other modes.

[OFFSET VECTOR]

Displays the three-dimensional tool compensaion vector created for each block.

1.10 OPERATION HISTORY

This function always collects history data for keys pressed by the NC operator and the states of signals set by the NC operator. In addition, this function enables the operator to monitor history data when necessary.

1.10.1 Display Method

Press the [HISTORY] soft key. Then, the OPERATION HISTORY screen is displayed. Smaller numbers represent older data.

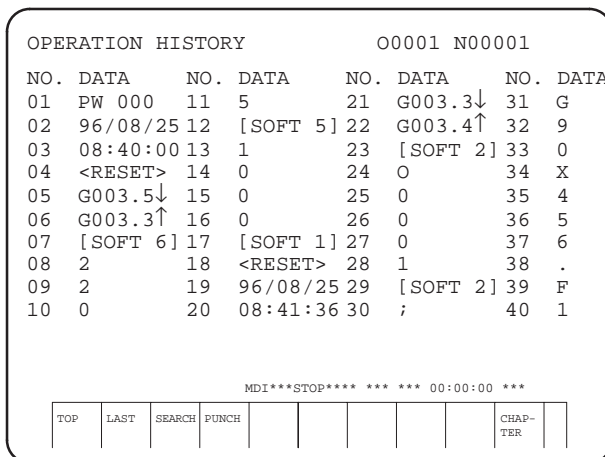

1.10.2 Soft Key Operation

- (1) TOP
Displays the first page of history data, which starts with oldest history data item.
- (2) LAST
Displays the last page of history data, which ends with the newest history data item.
- (3) SEARCH
By selecting the SEARCH key from the operation selection keys, the search operation described below can be performed.
 - (a) Signal data item
 - (i) Press the [DIDO] key.
 - (ii) Use one of the following search methods:
 1. Enter a signal type (X, Y, G, or F), address, decimal point (.), and bit number.
ExampleG3.5
When the entered signal type, address, and bit number agree with those of a history data item, that history data item is found.
 2. Enter a signal type (X, Y, G, or F) and address.
ExampleG3
When the entered signal type and address agree with those of a history data item, that history data item is found.
 3. Enter a signal type (X, Y, G, or F).
ExampleG
When the entered signal type agrees with that of a history data item, that history data item is found.

(b) Alarm data item

- (i) Press the [ALARM] key.
- (ii) Use one of the following search methods:
 1. Enter an alarm type and alarm number with keys.

ExampleOT7

When the entered alarm type and alarm number agree with those of a history data item, that history data item is found.

2. Enter an alarm type with keys.

ExampleOT

When the entered alarm type agrees with that of a history data item, that history data item is found.

(c) Time data

- (i) Press the [TIME] key.
- (ii) Use the following search method.

Enter month/date/hour/minute with keys. Less significant data can be omitted as shown in the example below.

ExampleMonth/date/hour/minute: 08/26/13/24

Month/date/hour: 08/26/13

Month/date: 08/26

Month: 08

NOTE

Enter the month, date, hour, and minute with two digits each.

After the above operations do the following:

To search for a history data item forward from the currently displayed history data (toward newer history data), press the [FW_SRCH] soft key.

To search for a history data item backward from the currently displayed history data (toward older history data), press the [BW_SRCH] soft key.

NOTE

Searching forward for a history data item terminates at the most recent history data item (last data item). Searching backward for a history data item terminates at the oldest history data item (first data item). If the specified history data item is not found, a warning is issued.

When the specified history data item is found during searching, the page of history data items that contains the specified history data item is displayed. The line number of the specified history data item is displayed in reverse video. Subsequently, this history data item is used as the (search pointer) during searching. When searching has not yet been performed, the oldest history data item (first data) is used as the search pointer. The search pointer is also used during partial punching-out.

Once history data has been searched for, the search pointer is kept until the power is turned off. When the memory for history data items becomes full, the first data in the history is automatically used as the search pointer.

(4) Outputting history data

History data can be output to the host computer via the RS-232-C interface.

(a) Press the [PUNCH] soft key (one of the operation selection keys) on the OPERATION HISTORY screen.

(b) The following punching-out can be performed:

(i) Complete punch-out

Press the [ALL] soft key, then press the [EXEC] soft key. All history data items are output.

(ii) Partial punch-out

1. Before starting partial punch-out, use the search function to determine the reference points for starting and ending partial punch-out. The search pointer is used as (reference history data item) for partial punch-out.

2. Specify the number of display lines of history data items to output.

Example1 To output 100 history data items forward from the reference history data item, press the [PART] soft key, enter 100, then press the [EXEC] soft key.

Example2 To output 100 history data items backward from the reference history data item, press the [PART] soft key, enter -100, then press the [EXEC] soft key.

Example3 To output all history data items forward from the reference history data item, press the [PART] soft key, enter 9999, then press the [EXEC] soft key.

Example4 To output all history data items backward from the reference history data item, press the [PART] soft key, enter -9999, then press the [EXEC] soft key.

NOTE

- 1 History data items are always output in the foreground.
- 2 The valid data range for partial punching is -9999 to 9999 excluding 0. 9999 and -9999 have the meanings described in the above examples.

When the number of history data items is less than the absolute value of the value entered, the entered numeric value is handled as if it were 9999 or -9999.

(c) History data items are output in ASCII code in the following format.

(i) MDI key

Example When the [A] key is pressed
[MDI] key pushed A LF

(ii) DI/DO

Example1 When the state of G003.5 changes from off to on
DI/DO changed G3.5_ON LF

Example2 When different signals with the same address are
changed at the same time
DI/DO changed F0.6_ONF0.1_OFF LF

(iii) Alarm

Example When the alarm, "PW000 TURN OFF THE
POWER" occurs
Alarm! PW0 at '92/8/30 23:17:56 LF

(iv) Time

Example1 At 23:17:56 on August 30, 1996
'96/8/30 23:17:56 LF

Example2 When the power is turned on
'96/8/30 23:17:56 Power On LF

(d) Communication protocol

Refer to the case where the NC sends data in "Transmission Method for the RS-232-C Interface" in the FANUC Series 15-B Operator's Manual (Operation).

(5) Erasing history data

(a) Press the [OPE_HIS] soft key (one of the chapter selection keys).

(b) Press the [ERASE] soft key (one of the operation selection keys).

(c) Press the [EXEC] soft key (one of the operation instruction keys).

When the [EXEC] soft key is pressed by mistake during selection, press the [CANCEL] soft key.

When operation history data is erased, the date and time it was erased is recorded at the beginning of new history data.



1.10.3 Select DI/DO Screen

Select the [DIDO SELECT] key. Then, the DI/DO SELECT screen is displayed.

DI/DO SELECT				O0001 N0001			
NO.	ADDRESS	SIGNAL	NO.	ADDRESS	SIGNAL		
01	X000	00001000	11	G000	00000001		
02	X004	10000000	12	G004	00000010		
03	X008	00001100	13	G008	00000011		
04	X009	00111000	14	G003	01011100		
05	X012	00001111	15	G043	00100001		
06	Y000	01000000	16	F000	01100010		
07	Y004	00110000	17		*****		
08	Y007	00011100	18		*****		
09	Y008	00011100	19		*****		
10	Y010	00011100	20	F020	10101010		

MDI	***	STOP	*****	***	00:00:00	***
CLEAR		ALL_CLR	ON:1	OFF:0	CHAPTER	+

Specifying data

1. Press the cursor keys  or  to move the cursor to the position to enter data.
2. Enter a signal type (X, Y, G, or F) and address, then press the [INPUT] soft key.

Example Y4([INPUT] key)

Valid data range: G0 to G511, F0 to F319, X0 to X127, or Y0 to Y127

3. Specify signal address Y004 in the ADDRESS column, then set the SIGNAL column to the initial value (00000000).
4. The operation selection keys have the following functions:
 - (i) CLEAR
When the [CLEAR] soft key and the [EXEC] soft key are pressed, the signal data at the cursor is deleted. The contents of the signal field is changed to *****, and the address field is cleared. When the [CLEAR] soft key is pressed by mistake, press the [CANCEL] key.
 - (ii) ALL_CLR
When the [ALL_CLR] soft key and the [EXEC] soft key are pressed, all specified data items are deleted. When the [ALL_CLR] soft key is pressed by mistake, press the [CANCEL] key.
 - (iii) ON:1
Press this soft key to set all bits of the data item at the cursor to 1.
 - (iv) OFF:0
Press this soft key to set all bits of the data item at the cursor to 0.
 - (v) INPUT
This soft key is used to enter a signal address. It is also used to enter the value of the signal after a signal address is entered.

NOTE

Changes in signals cannot be deleted unless they continue for longer than 16ms.

1.10.4 Related Parameters

- Parameter No. 0013#5: Specifies whether to display DI/DO history information.
- Parameter No. 0013#4: Specifies whether to display MDI key operation history information.
- Parameter No. 0015#4: Specifies whether to display the deletion key.
- Parameter No. 0015#3: Specifies whether to display the OPERATION HISTORY screen.

1.11 OPERATION LIST

Classification	Function	Data protection key	PWE =1 (DATA No. 8000)	Mode selection	Function key	
Clear	Tool offset Value	KEY 1		Power ON	OFFSET	Operation menu key → [ALL-CLR] → [ALL], [WEAR], or [GEOMETRY]
Data Input From Tape	One Program Input (program number not changed)	KEY 3		EDIT	PRGRM	Operation menu key → [READ] → [1-PRGRM] → [NEW]
	One Program Input (program number changed or added)	KEY 3		EDIT	PRGRM	Operation menu key → [READ] → [(PROG#)] → Program number → [EXEC]
	Add Program	KEY 3		EDIT	PRGRM	Operation menu key → [READ] → [1-PRGRM] → [ADD]
	Registration of all programs	KEY 3		EDIT	PRGRM	Operation menu key → [READ] → [ALL]
	Pitch Error Compensation amount		○	Emergency SW. ON.	SERVICE	[PITCHH] → [READ]
Data Input From MDI	Parameter		○	MDI or Emergency switch ON.	SERVICE	[PARAM] → [INP-No.] → [ON:1] [OFF:0] Data No. → [EXEC] → [INPUT] [+INPUT]
	Offset Value	KEY 1			OFFSET	Operation menu key → [INPUT] (Absolute input) [+INPUT] (Incremental input) → Offset value → [EXEC]
	Setting Data	KEY 2		MDI	SETTING	Operation menu key → [HANDY] (Setting relating to I/O) [GENERAL] (Settable parameter) → [1 : ON] [0 : OFF] → Data → [EXEC] [(VALUE)]

Classification	Function	Data protection key	PWE =1 (DATA No. 8000)	Mode selection	Function key	
Output	Parameter, Pitch error compensation data			EDIT	SERVICE	Operation menu key → [PUNCH] → [ALL] [PARAM] [PITCH]
	Offset Value			EDIT	OFFSET	Operation menu key → [PUNCH] → [TOOL]
	All Program	KEY 3		EDIT	PRGRM	Operation menu key → [PUNCH] → [ALL]
	One Program	KEY 3		EDIT	PRGRM	Operation menu key → [PUNCH] → [THIS] or [PUNCH] → [(PROG#)] → Program number → [EXEC]
Search	Program No. Search (Programs in memory)	KEY 3		EDIT or MEMORY	PRGRM	Operation menu key → [FW-SRCH] → [(PROG#)] → Program number → [EXEC]
	Sequence No. Search (Sequence No. in memory)	KEY 3		EDIT or MEMORY	PRGRM	Operation menu key → [FW-SRCH] → [(SEQ#)] → Sequence number → [EXEC]
	Sequence No. Search (Sequence Nos. on tape)			TAPE	PRGRM	[CHAPTER] → [TEXT] Operation menu key → [FW-SRCH] → [(SEQ#)] → Sequence num → [EXEC]
	Word Search (Words in memory)	KEY 3		EDIT	PRGRM	[CHAPTER] → [TEXT] → Operation menu key → [FW-SRCH] or [BW-SRCH] [(WORD)] → Word to be searched → [EXEC]
	Address Search (Addresses in memory)	KEY 3		EDIT	PRGRM	[CHAPTER] → [TEXT] → Operation menu key → [FW-SRCH] or [BW-SRCH] [(WORD)] → Word to be searched → [EXEC]

Classification	Function	Data protection key	PWE =1 (DATA No. 8000)	Mode selection	Function key		
Program Editing	Deletion of all Programs	KEY 3		EDIT	PRGRM	Operation menu key → [DELETE] → [PROGRAM] → [ALL] → [EXEC]	
	Deletion of a Program	Currently displayed program	KEY 3		EDIT	PRGRM	Operation menu key → [DELETE] → [PROGRAM] → [THIS]
		Designated program	KEY 3		EDIT	PRGRM	Operation menu key → [DELETE] → [PROGRAM] → [(PROG#)] → Program number → [EXEC]
	Deletion of words, from cursor positioned to designated word	KEY 3		EDIT	PRGRM	Operation menu key → [DELETE] → [~(WORD)] → Word → [EXEC]	
	Deletion of words from cursor position to EOB	KEY 3		EDIT	PRGRM	Operation menu key → [DELETE] → [~EOB]	
	Deletion of one word	KEY 3		EDIT	PRGRM	Operation menu key → [DLT→WRD] or [DELETE]→ [WORD]	
	Alternation of a word	KEY 3		EDIT	PRGRM	Operation menu key → [ALTER] [(WORD)]→ Word to changed → [EXEC]	
	Insertion of a word	KEY 3		EDIT	PRGRM	Operation menu key → [INSERT] [(WORD)]→ Word to changed → [EXEC]	
	All Program Memory Arrangement	KEY 3		EDIT	PRGRM	Operation menu key → [CONDENS] → [ALL]	
	Currently Selected Program Memory Arrangement	KEY 3		EDIT	PRGRM	Operation menu key → [CONDENS] → [THIS]	
	Designated Program Memory Arrangement	KEY 3		EDIT	PRGRM	Operation menu key → [CONDENS] [(PROG#)]→ Program number → [EXEC]	
Comparison	Comparison all Programs in Memory with those on tape			EDIT	PRGRM	Operation menu key → [VERIFY] → [ALL]	
	Comparison one Program in Memory with that on tape			EDIT	PRGRM	Operation menu key → [VERIFY] → [1-PRGRM]	
	Comparison from Current Position			EDIT	PRGRM	Operation menu key → [VERIFY] → [HERE]	

Classification	Function	Data protection key	PWE =1 (DATA No. 8000)	Mode selection	Function key	
I/O to or from FANUC cassette	File head search			EDIT	PRGRM	Operation menu key → [SERCHFILE] → [TOP] → [EXEC] Operation menu key → [SERCHFILE] → [(FILE#)] → [EXEC] Operation menu key → [SERCHFILE] → [(FILE NAME)] → [EXEC]
	File deletion			EDIT	PRGRM	Operation menu key → [DELFILE] → [(FILE#)] → N[File name] → [EXEC] Operation menu key → [DELFILE] → [(FILE NAME)] → N[File name] → [EXEC] Operation menu key → [DELFILE] → [ALL] → [EXEC]
	Program registration	KEY 3		EDIT	PRGRM	Operation menu key → [READ] → [(FILE#)] → N[File No.] → [EXEC] Operation menu key → [READ] → [(PROG#)] → O[Program No.] → [EXEC] Operation menu key → [READ] → [(FILE NAME)] → [File name] → [EXEC]
	Output of all programs	KEY 3		EDIT	PRGRM	Operation menu key → [PUNCH] → [ALL]
	Output of one program	KEY 3		EDIT	PRGRM	Operation menu key → [PUNCH] → [THIS] or [PUNCH] → [(PROG#)] O[Program No.] → [EXEC] Operation menu key → [PUNCH] → [(FILE NAME)] "[File name] → [EXEC] Operation menu key → [PUNCH] → [(FILE#)] → N[File No.] → [EXEC]
	Change of file name			EDIT	PRGRM	Operation menu key → [RENAME] → [(FILE#)] → N[File No.] → "[File name] → [EXEC]

Classification	Function	Data protection key	PWE =1 (DATA No. 8000)	Mode selection	Function key	
Manual operation	Manual reference position return			JOG		Set the reference position return switch to ON. → Set the +X, -X, +Y, and -Y switches to ON. → The reference position return completion lamp lights.
	Jog feed			JOG		Set the +X, -X, +Y, and -Y switches to ON. → Specify the feedrate using the jog feedrate dial. → Press the rapid traverse button to perform rapid traverse.
	Incremental feed			INC		Specify the travel using the travel selection switch. → Set the +X, -X, +Y, and -Y switches to ON. → Press the rapid traverse button to perform rapid traverse.. → During rapid traverse, rapid traverse override is enabled.
	Manual handle feed			HANDLE		Select the axis to move, using the axis selection switch. → Turn the handle. → Specify the magnification using the handle magnification switch.
Graphic function	Parameter setting				GRAPH-IC	[GRAPH PARAM]
	Tool path				GRAPH-IC	Selection of graphic screen
						[GRAPH]
						Graphic start/end
						Automatic or manual operation
						Erasing graphic screen
						[ERASE]
Magnification						
[ENLARGE]						
Help function	Displaying INITIAL MENU screen				SHIFT + HELP	
	Displaying ALARM HELP screen				SHIFT + HELP	[1 ALARM]" Scroll to the required screen by using the <PAGEUP> or <PAGEDOWN> key, enter the number, then press the <INPUT> key to display the screen.
	Displaying ALARM HELP screen when alarm occurred			Alarm status	SHIFT + HELP	The alarm help screen is displayed. Press the <PAGEUP> or <PAGEDOWN> key to display other information. Press the <INPUT> key to display all alarms.
	Displaying SOFT KEY HELP screen				SHIFT + HELP	[2.SOFT KEY]" Scroll to the desired screen by pressing the <PAGEUP> or <PAGEDOWN> key.
Displaying DIAGNOSTIC screen					SERVICE	[DGNOS] 1. Page change keys 2. Number of the diagnostic data

2

HARDWARE

This chapter describes the overall configuration of the CNC control section, the interconnections between the units, the functions of the PC boards, and the functions of the modules on the PC boards.

2.1	STRUCTURE	52
2.2	OUTLINE OF HARDWARE	53
2.3	TOTAL CONNECTION	56
2.4	INTER-MACHINE CONNECTION	68
2.5	LIGHTING OF ALARM LEDS ON PCBS	92
2.6	LIST OF THE PCBS AND UNITS	163
2.7	HOW TO REPLACE THE MODULES	176
2.8	HOW TO REPLACE THE BATTERIES	177
2.9	HOW TO REPLACE FAN MOTOR	179
2.10	FUSE REPLACEMENT IN POWER SUPPLY UNIT ..	181
2.11	MAINTENANCE OF HEAT PIPE TYPE HEAT EXCHANGER	182
2.12	ADJUSTING THE LIQUID-CRYSTAL DISPLAYS ...	185
2.13	REPLACING THE FUSES OF THE LIQUID-CRYSTAL DISPLAYS	187
2.14	REPLACING THE LCD BACKLIGHT	188
2.15	HOW TO REPLACE THE CRT DISPLAY	189
2.16	HOW TO REPLACE THE MDI KEYBOARD	190
2.17	HOW TO REPLACE THE CARD CAGE IN THE CONTROL UNIT	191
2.18	HANDLING MEMORY CARDS	192

2.1 STRUCTURE

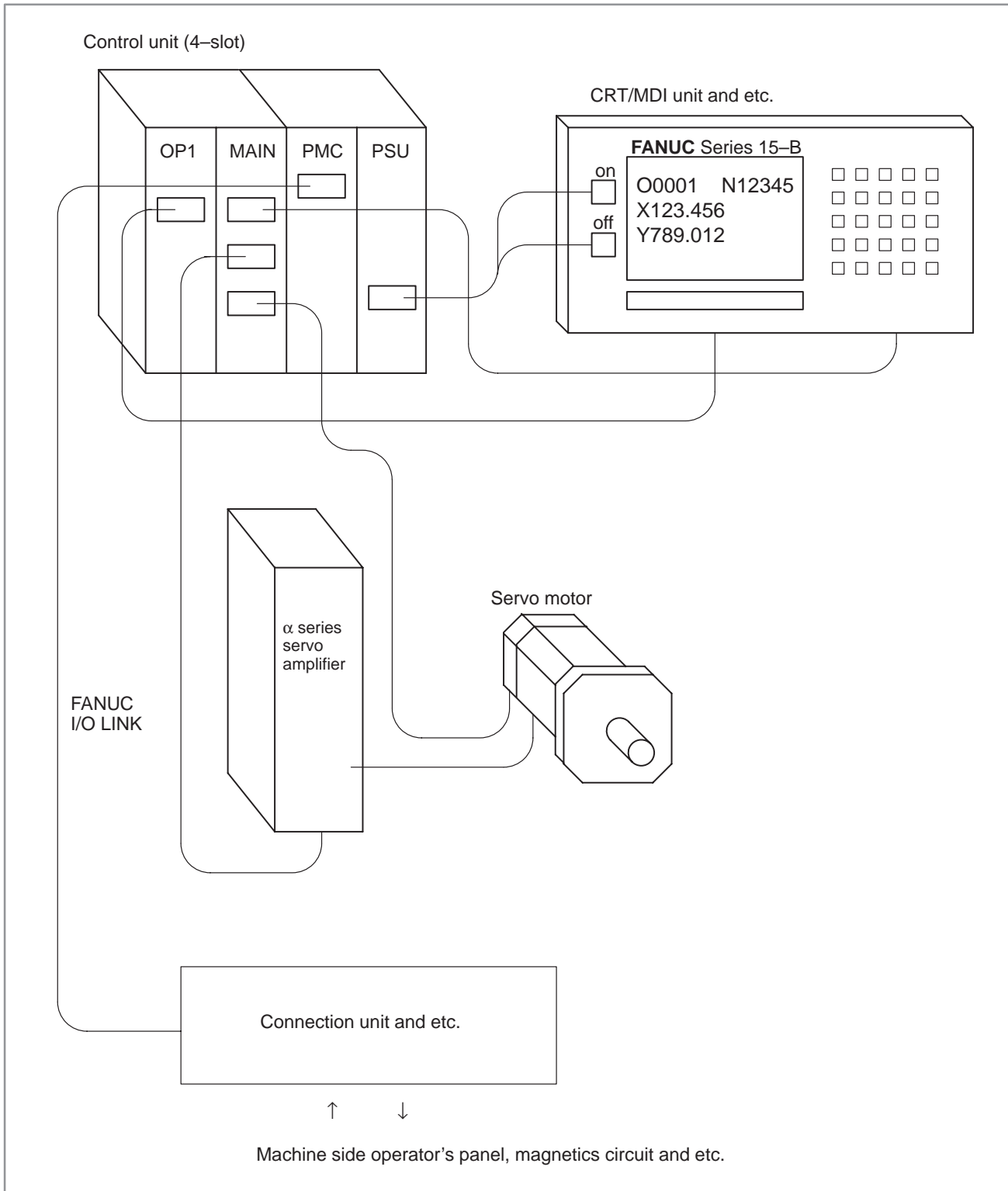

2.2 OUTLINE OF HARDWARE

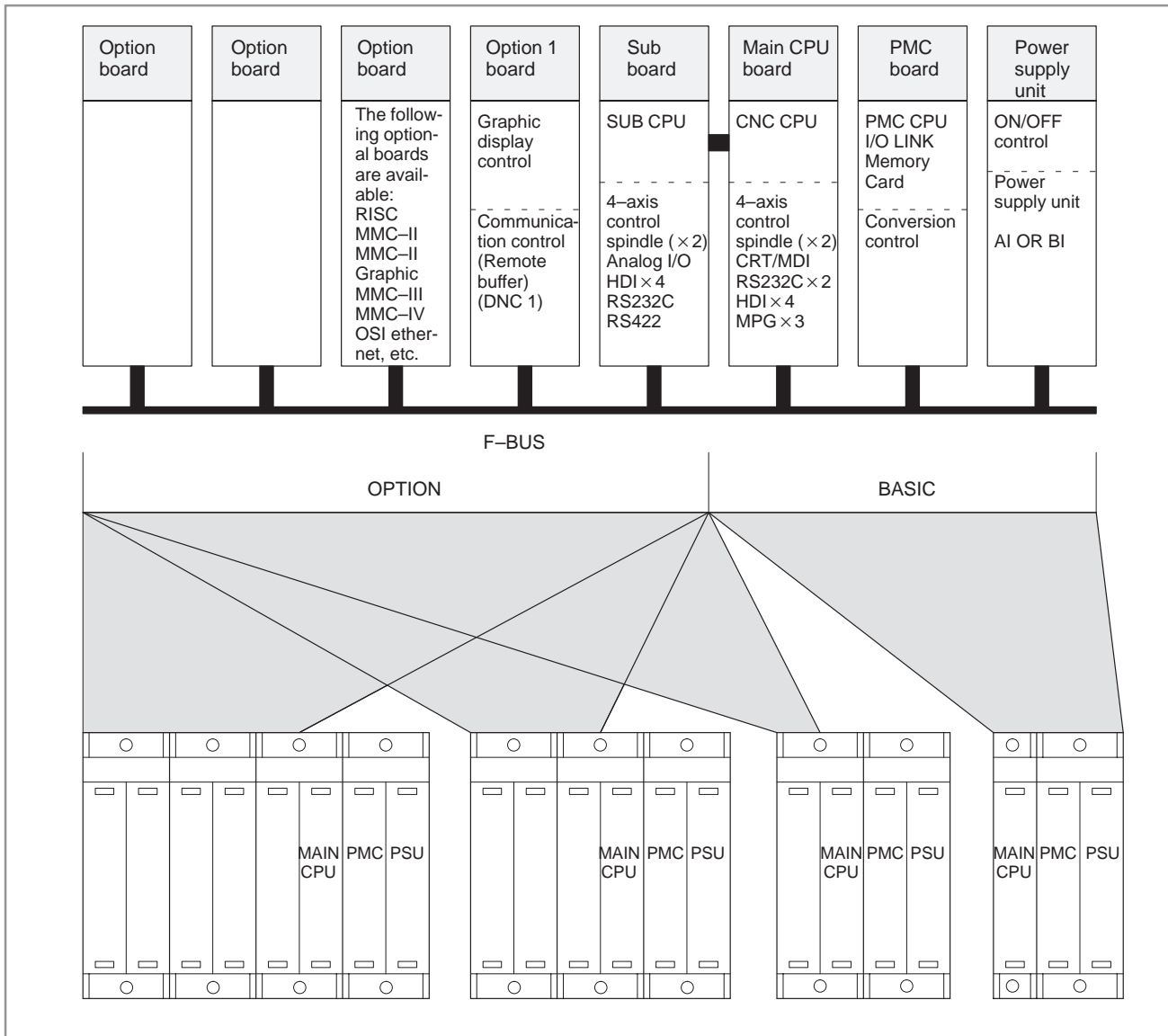

Fig. 2.2 (a) Control unit configuration of Series 15/150-B

NOTE

With the Series 15MEK/MEL/TED/TEE/TEF/TEF-B-4, the SUB CPU, RISC, and OSI Ethernet boards cannot be used. (The MMC board can be used only with the Series 150-B.)

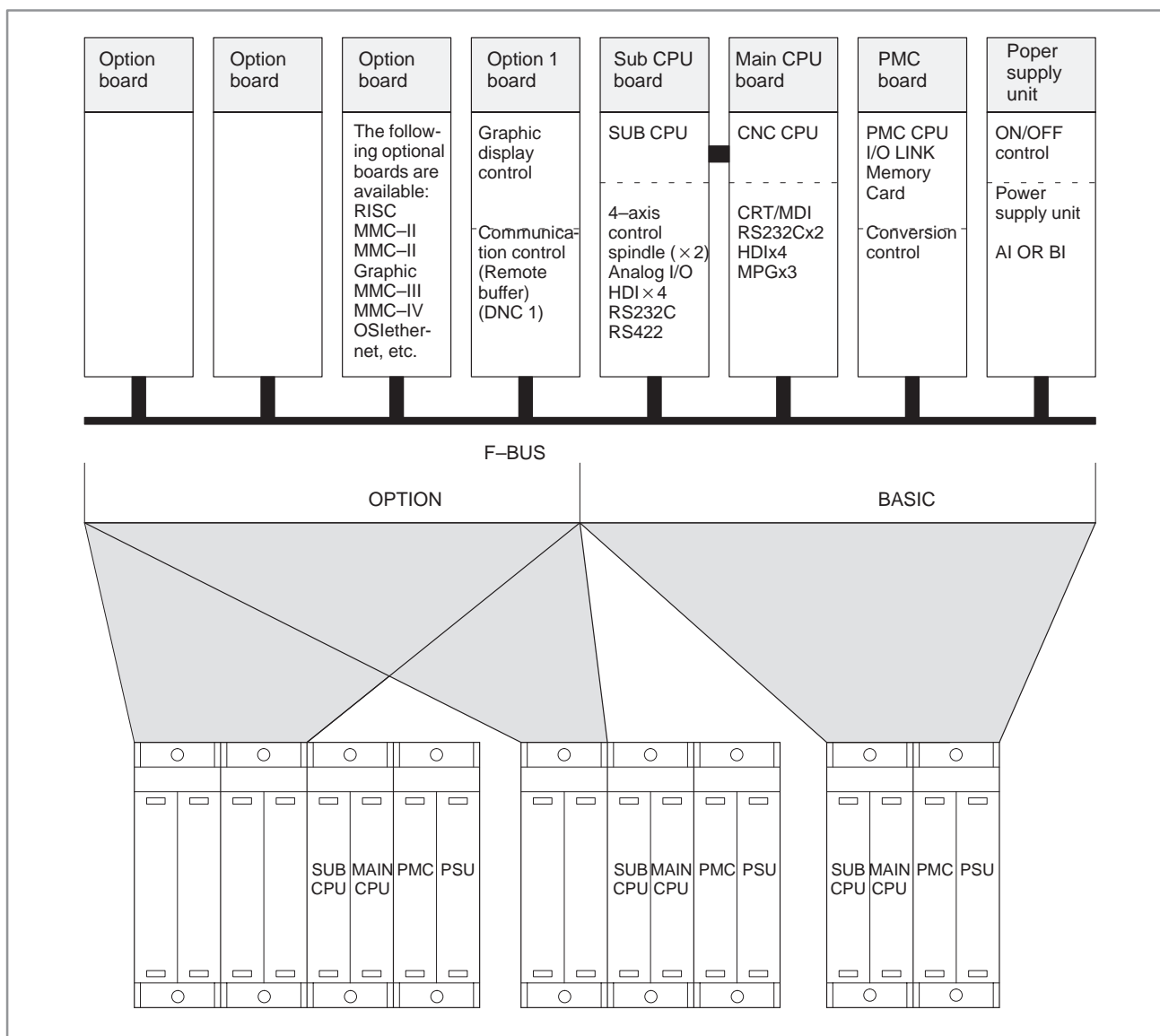

Fig. 2.2 (b) Control unit configuration of Series 15/150-B (Multiple axis)

NOTE

With the Series 15MEK/MEL/TED/TEE/TEF/TEF-B-4, the SUB CPU, RISC, and OSI Ethernet boards cannot be used. (The MMC board can be used only with the Series 150-B.)

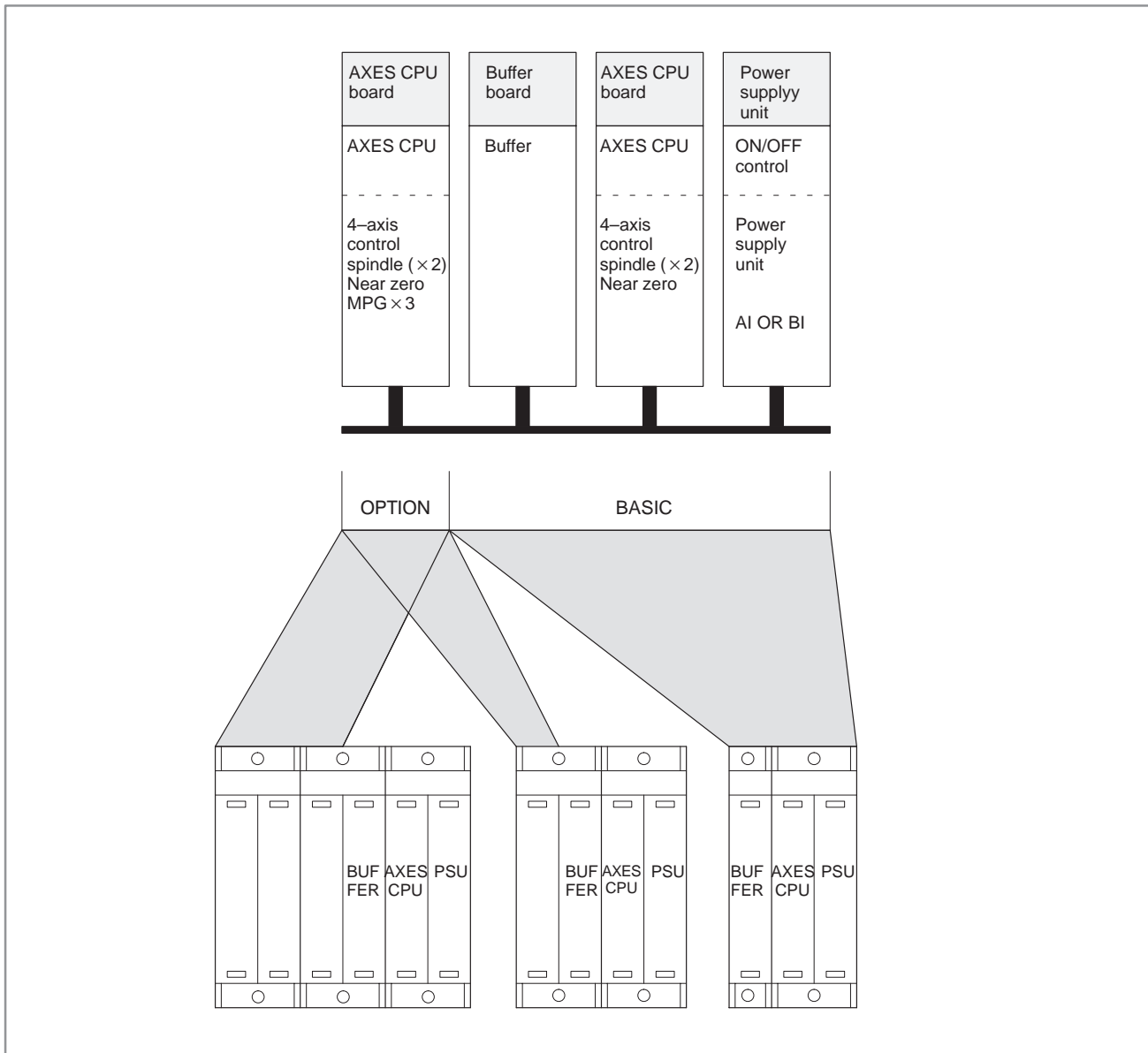

Fig. 2.2 (c) Configuration of Series 15/150-B additional locker used with multi-axis machines

NOTE
 More than one axis CPU board may be used, depending on the system configuration.

2.3

TOTAL CONNECTION

Connection diagram for Series 15-TB/TTB/MB/TFB/TTFB/MFB/MEK/MEL/
TED/TEE/TEF, Series 150-TB/MB/TTB (in case of serial spindle)

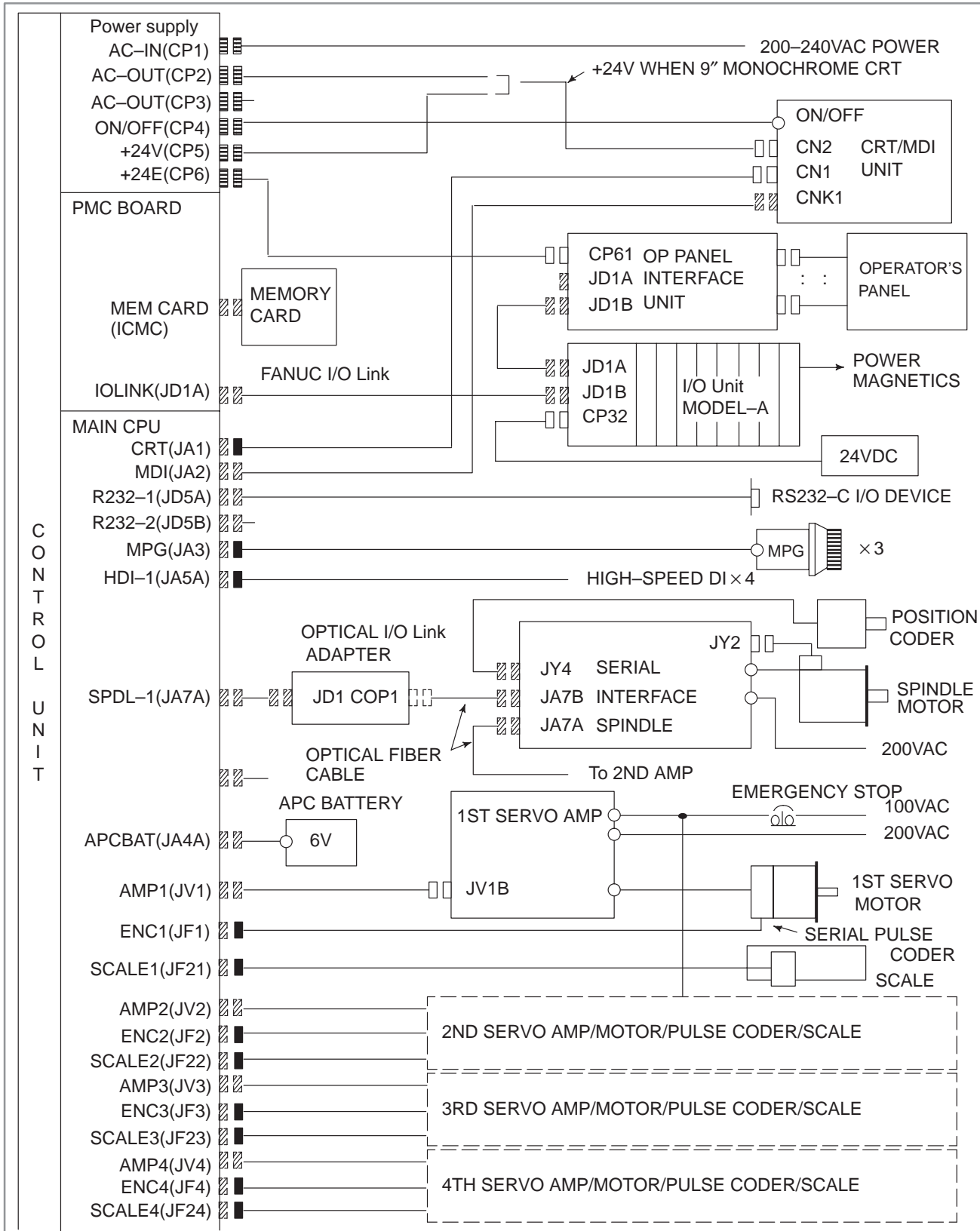

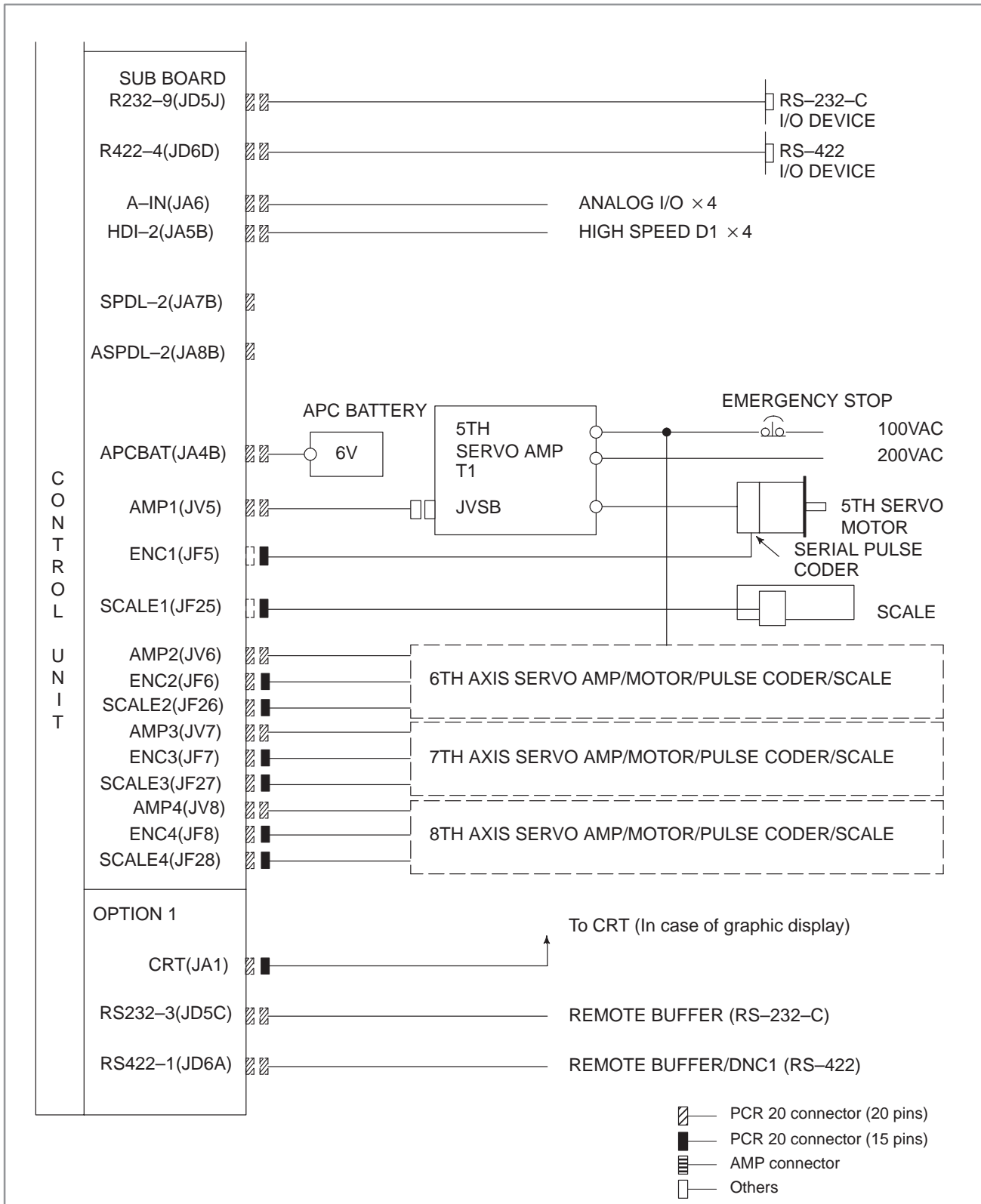

NOTE
 Some connections in the above diagram may not be provided, depending on the system configuration.

**Connection diagram for Series 15-TB/TTB/MB/TFB/TTFB/MFB/MEK/MEL/
TED/TEE/TEF, Series 150-TB/MB/TTB (in case of analog spindle)**

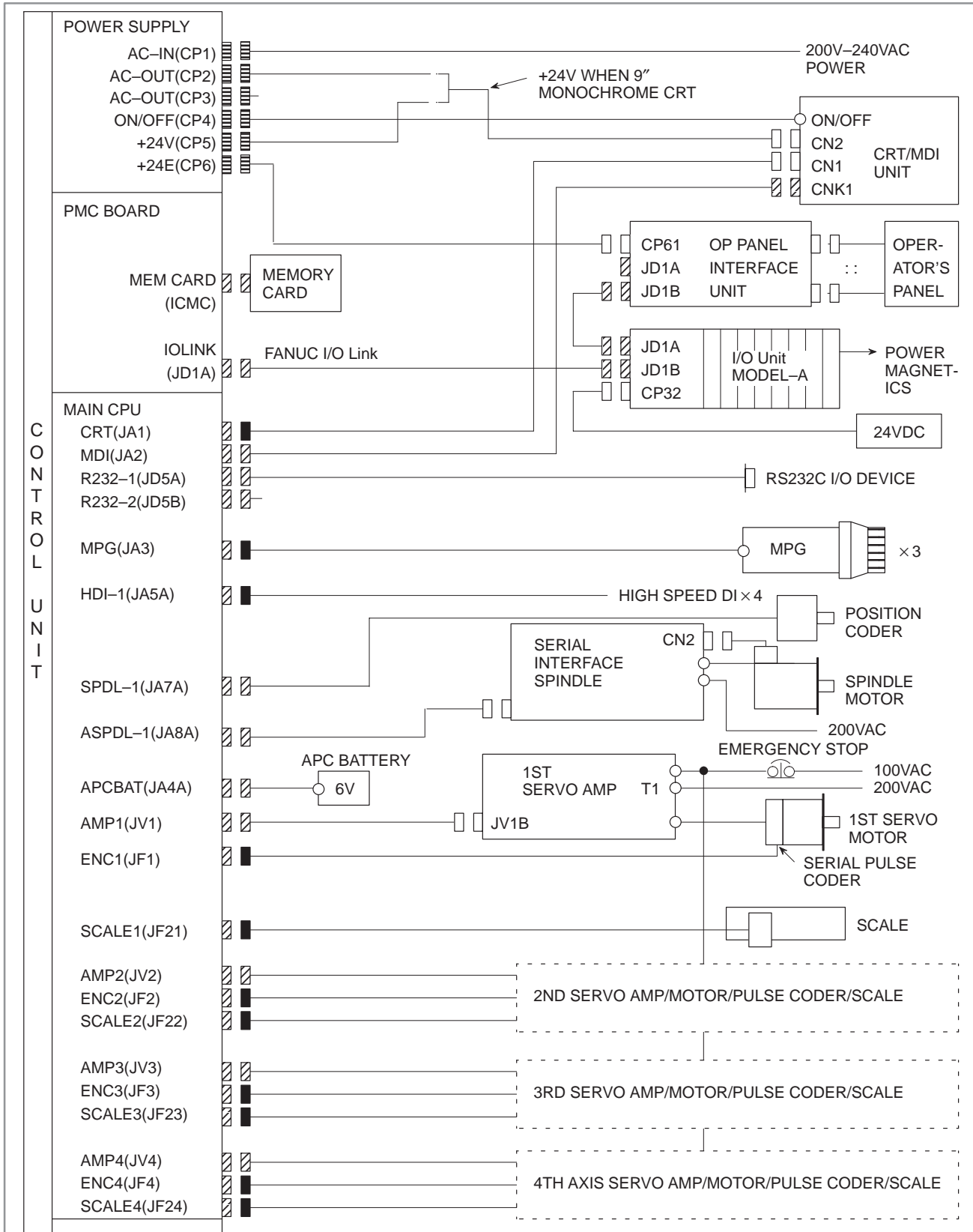

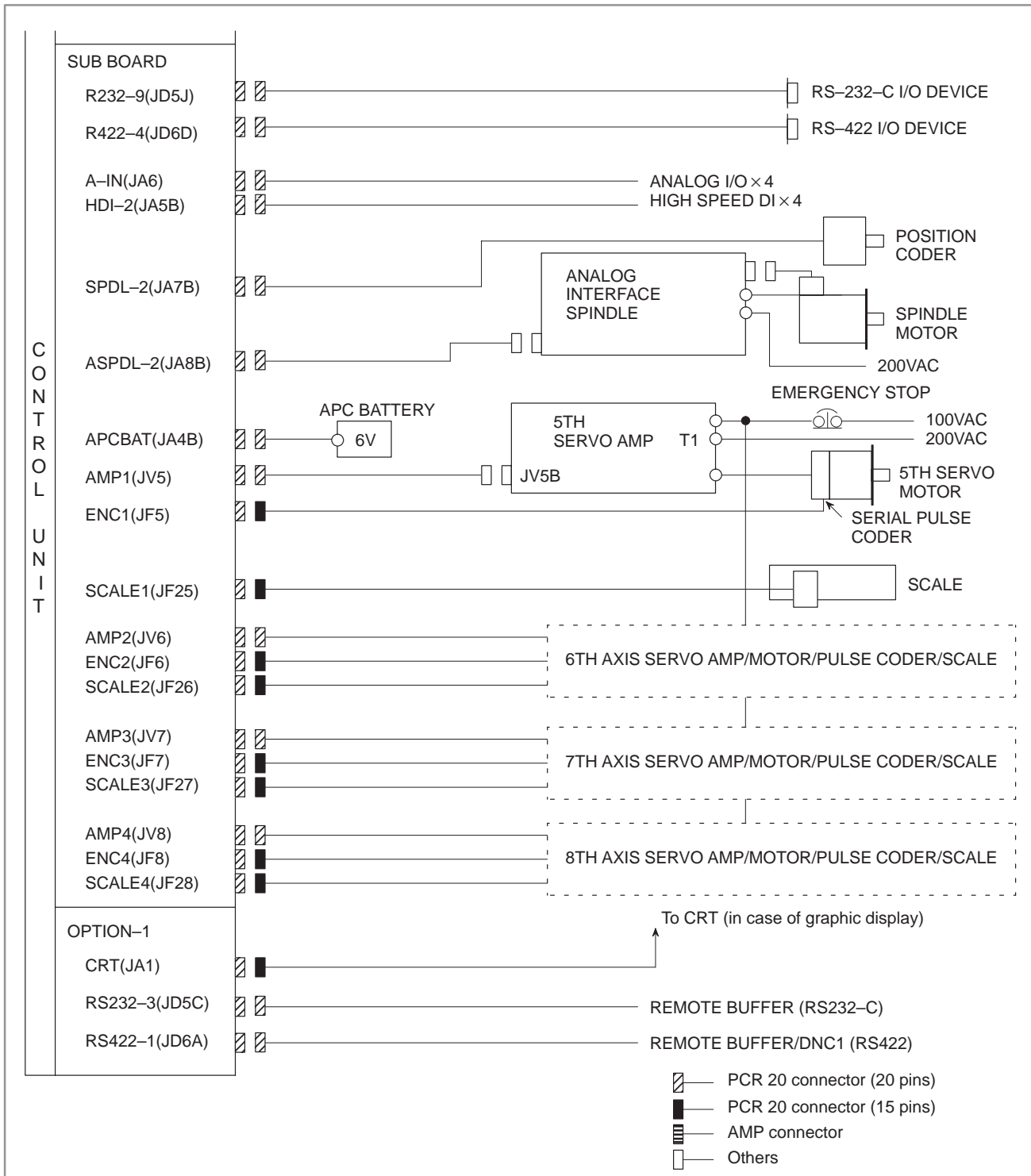

NOTE
 Some connections in the above diagram may not be provided, depending on the system configuration.

Connection diagram for Series 15-MB (incase of multiple axis)

● Control unit

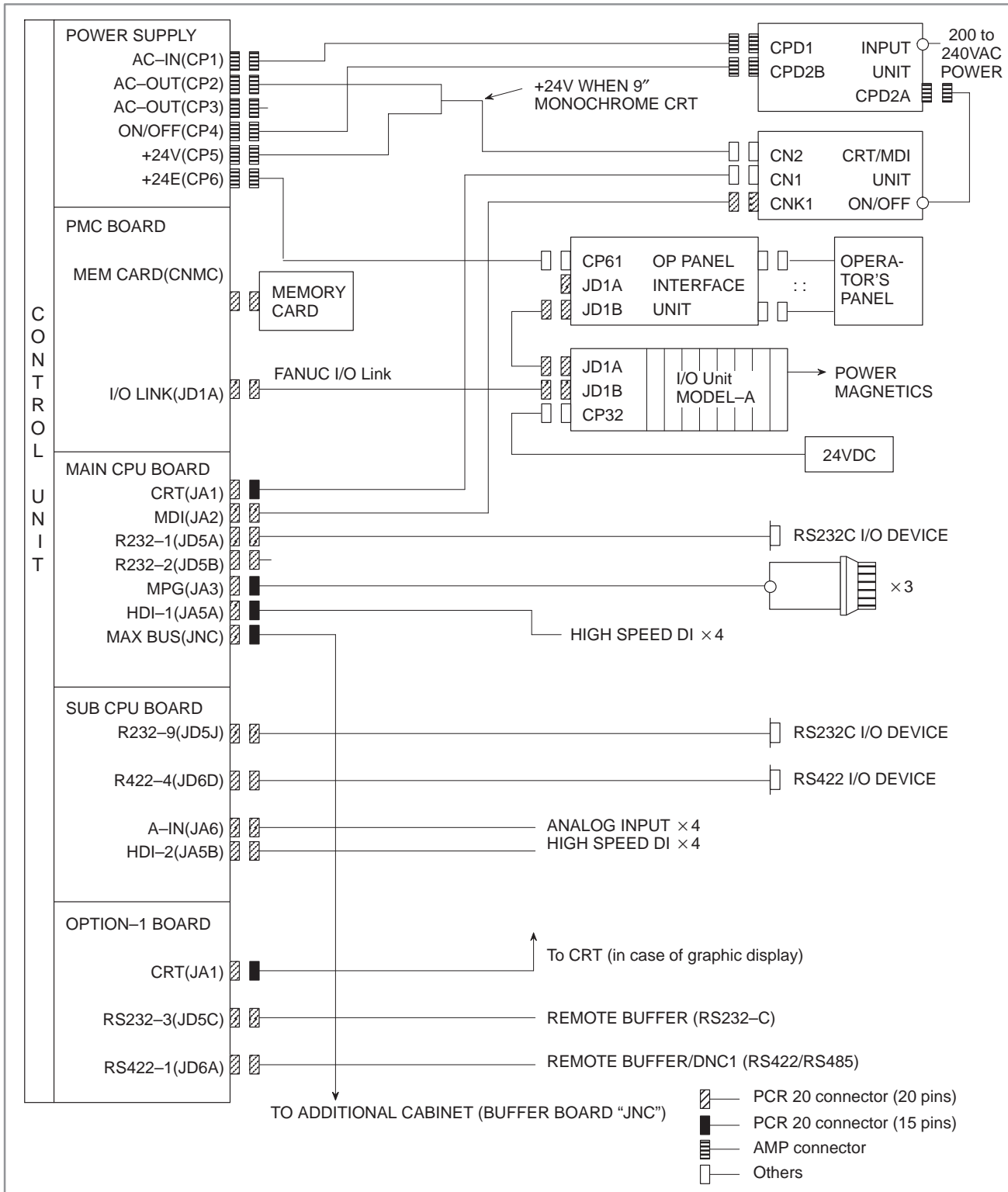

NOTE
 Some connections in the above diagram may not be provided, depending on the system configuration.

Additional cabinet (in case of serial spindle interface)

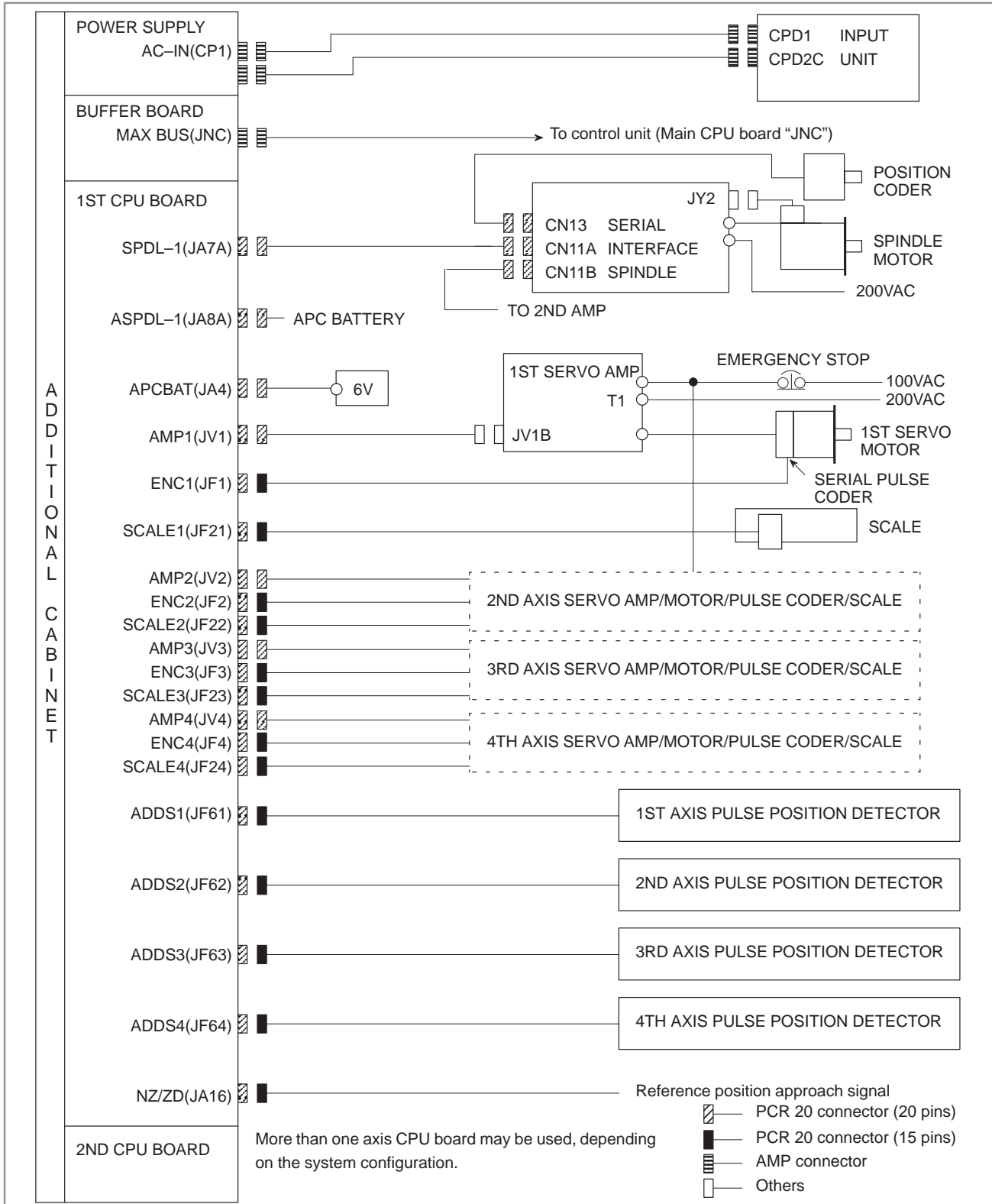

NOTE

Some connections in the above diagram may not be provided, depending on the system configuration.

Additional cabinet (in case of analog spindle interface)

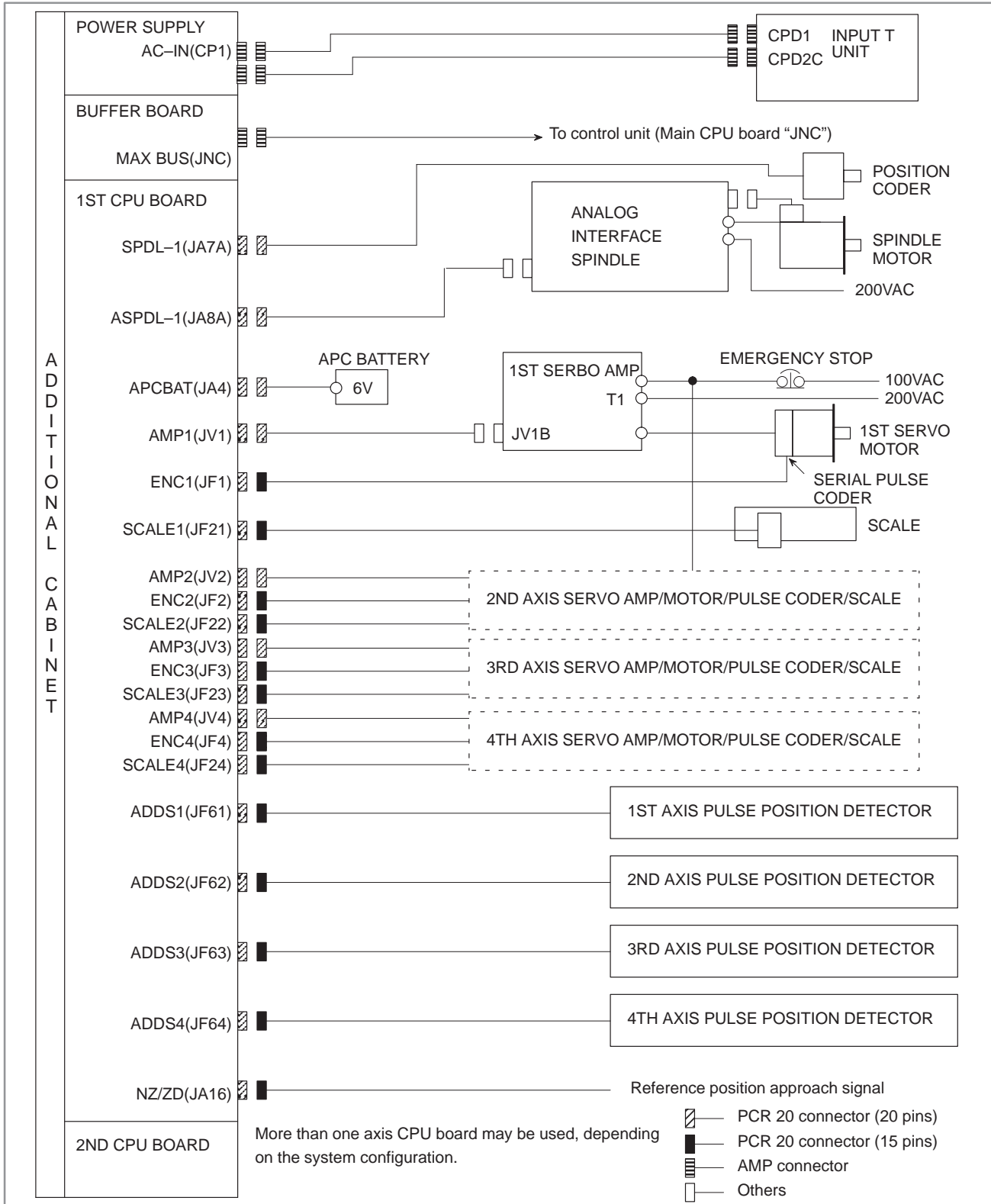

NOTE
Some connections in the above diagram may not be provided, depending on the system configuration.

**Connection diagram for Series 15-TB/TTB/MB/MEL/TEE
(in case of graphic function built-in type LCD/MDI unit)**

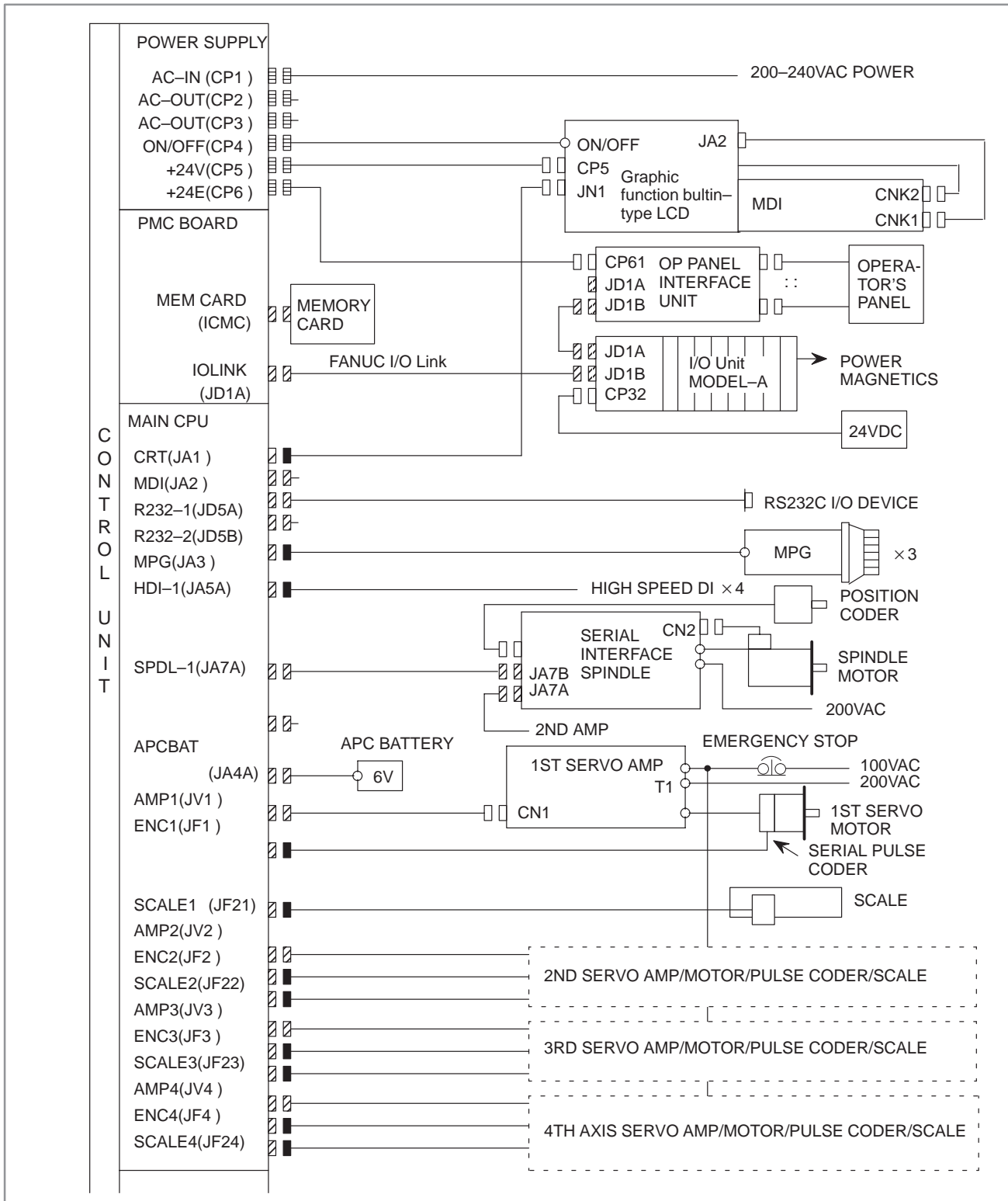

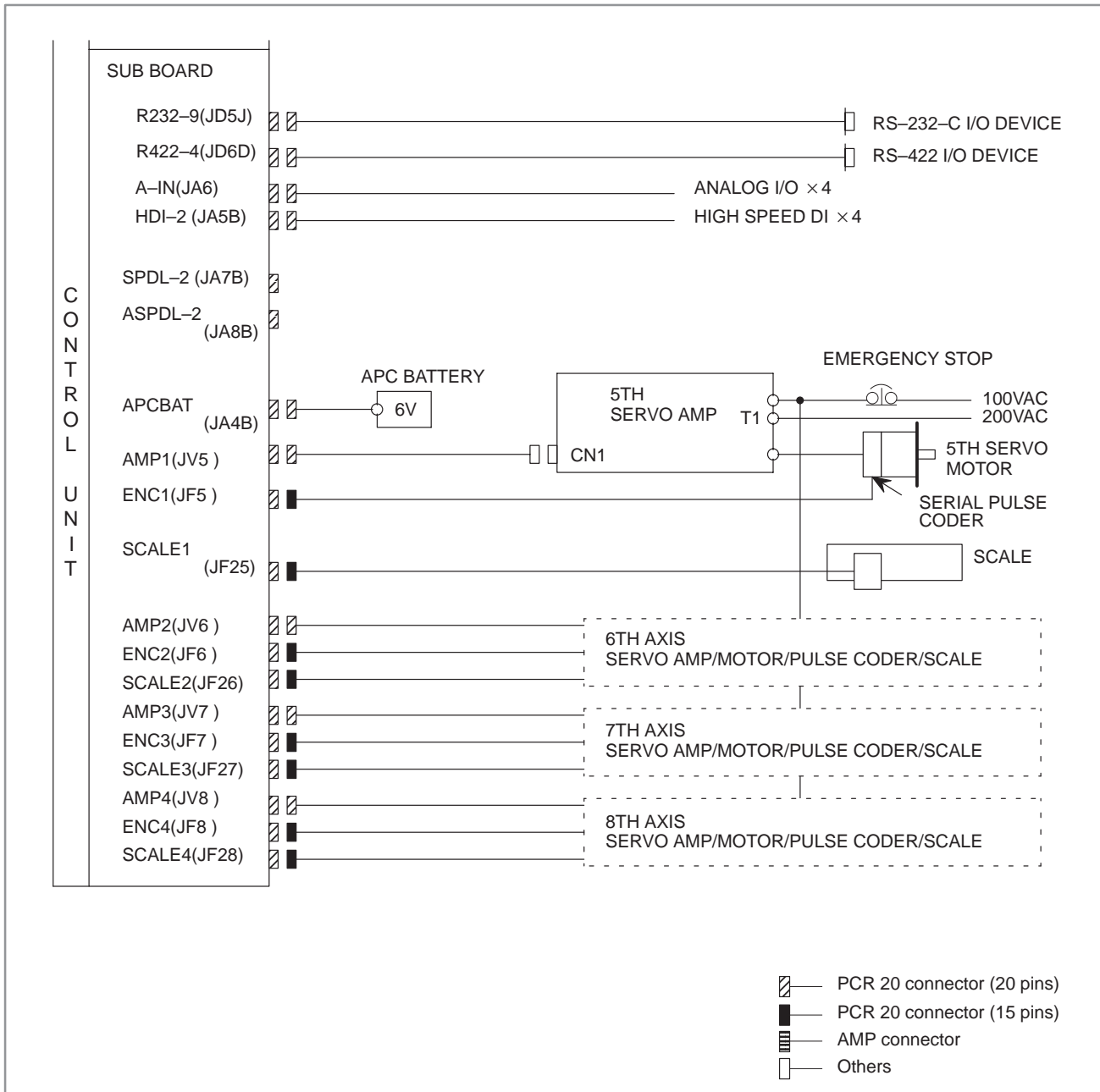

NOTE
 Some connections in the above diagram may not be provided, depending on the system configuration.

Connection diagram for MMC-II

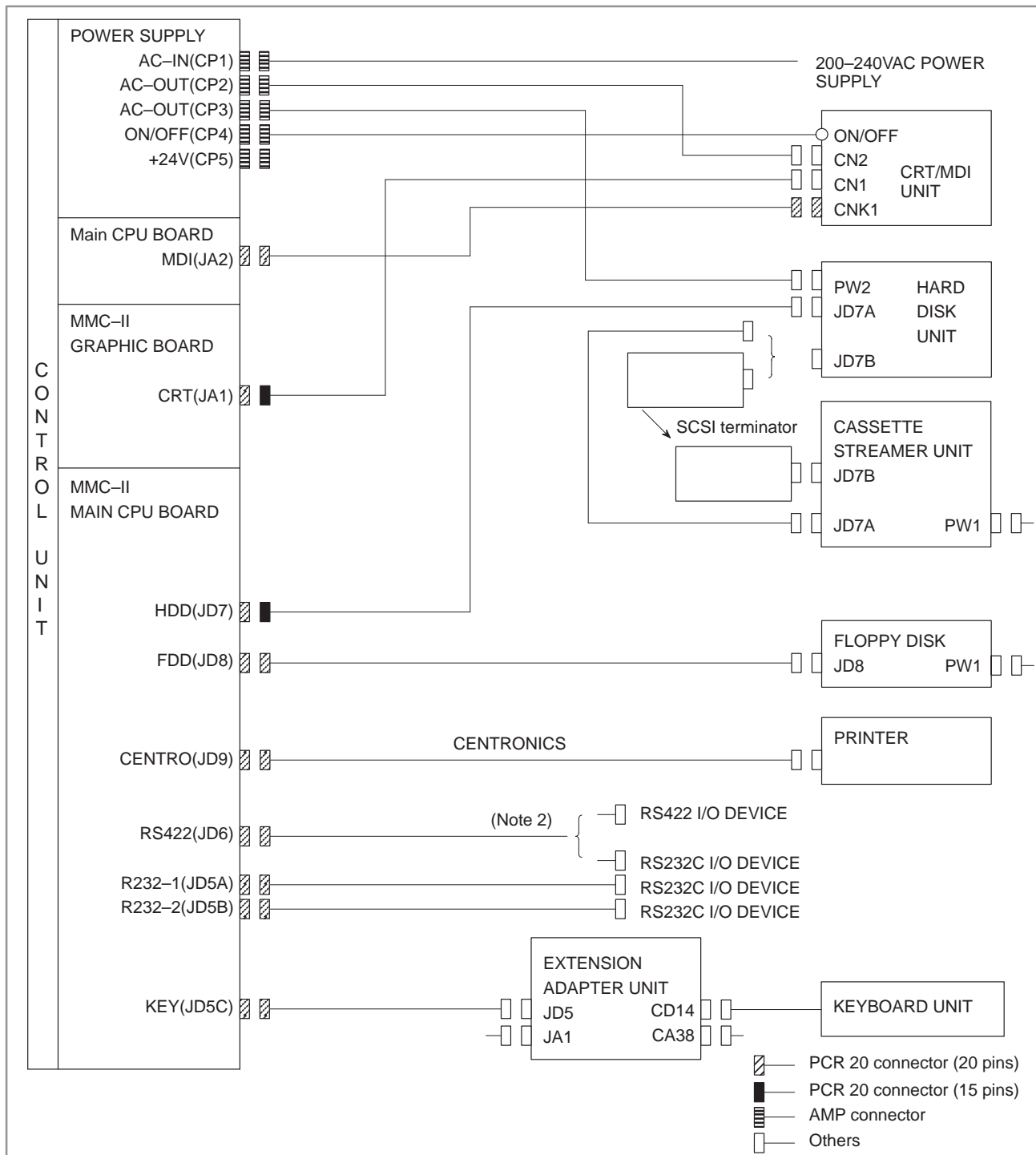

NOTE

- 1 The above diagram shows the connections between the MMC-II and peripheral devices. For details of the other connections, see 4.1, 4.2, and 4.3.
- 2 The MMC-II CPU (A02B-0120-J202), which requires three RS-232C channels, uses JD6 as an RS-232C port.
- 3 The MMC board can be used only with the Series 150-B.

Connection diagram for MMC-III

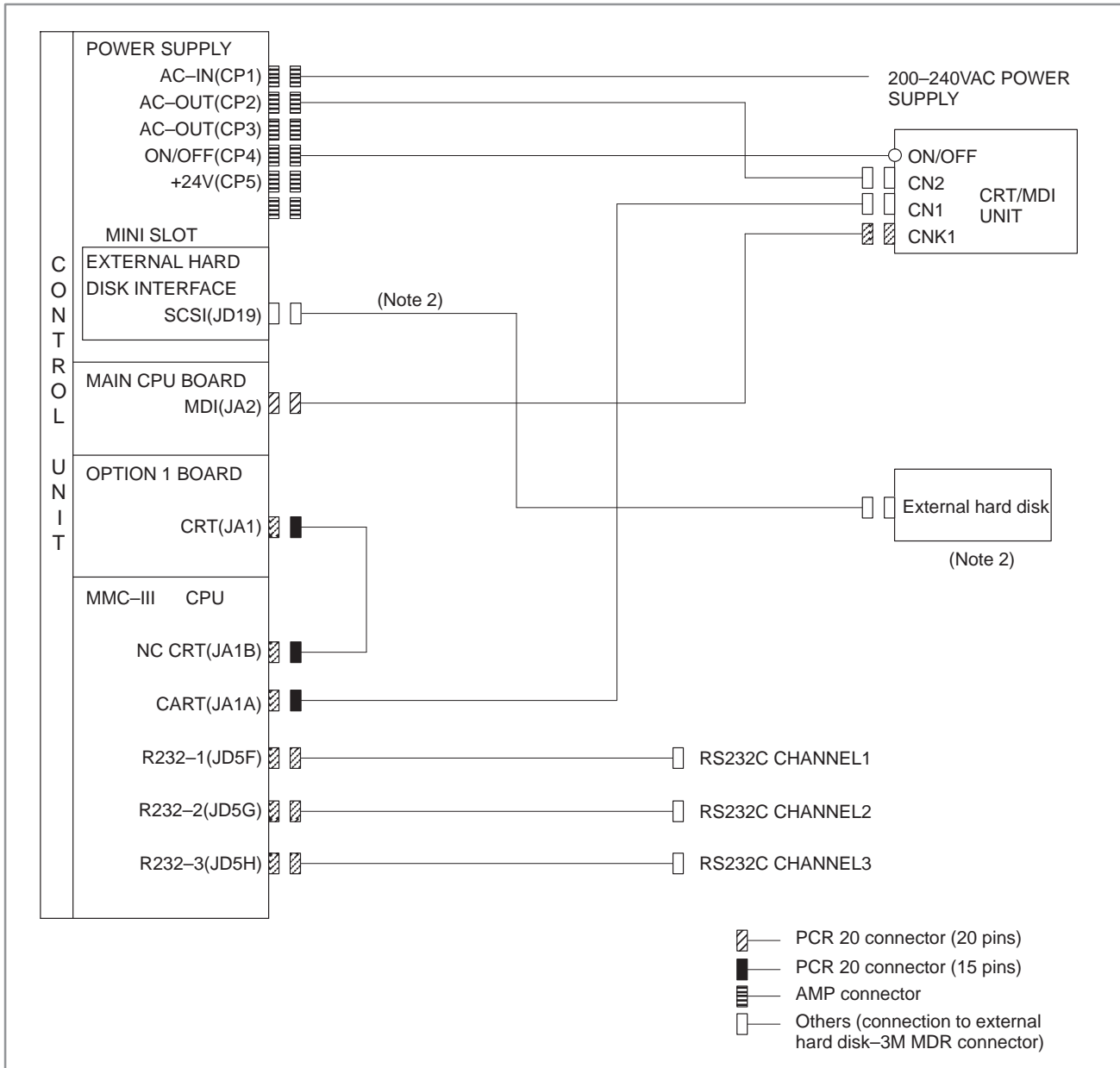

NOTE

- 1 The above diagram shows the connections between the MMC-III and peripheral devices. For details of the other connections, see 4.1, 4.2, and 4.3.
- 2 Used for application download only.
- 3 The MMC board can be used only with the Series 150-B.

Connection diagram for MMC-IV

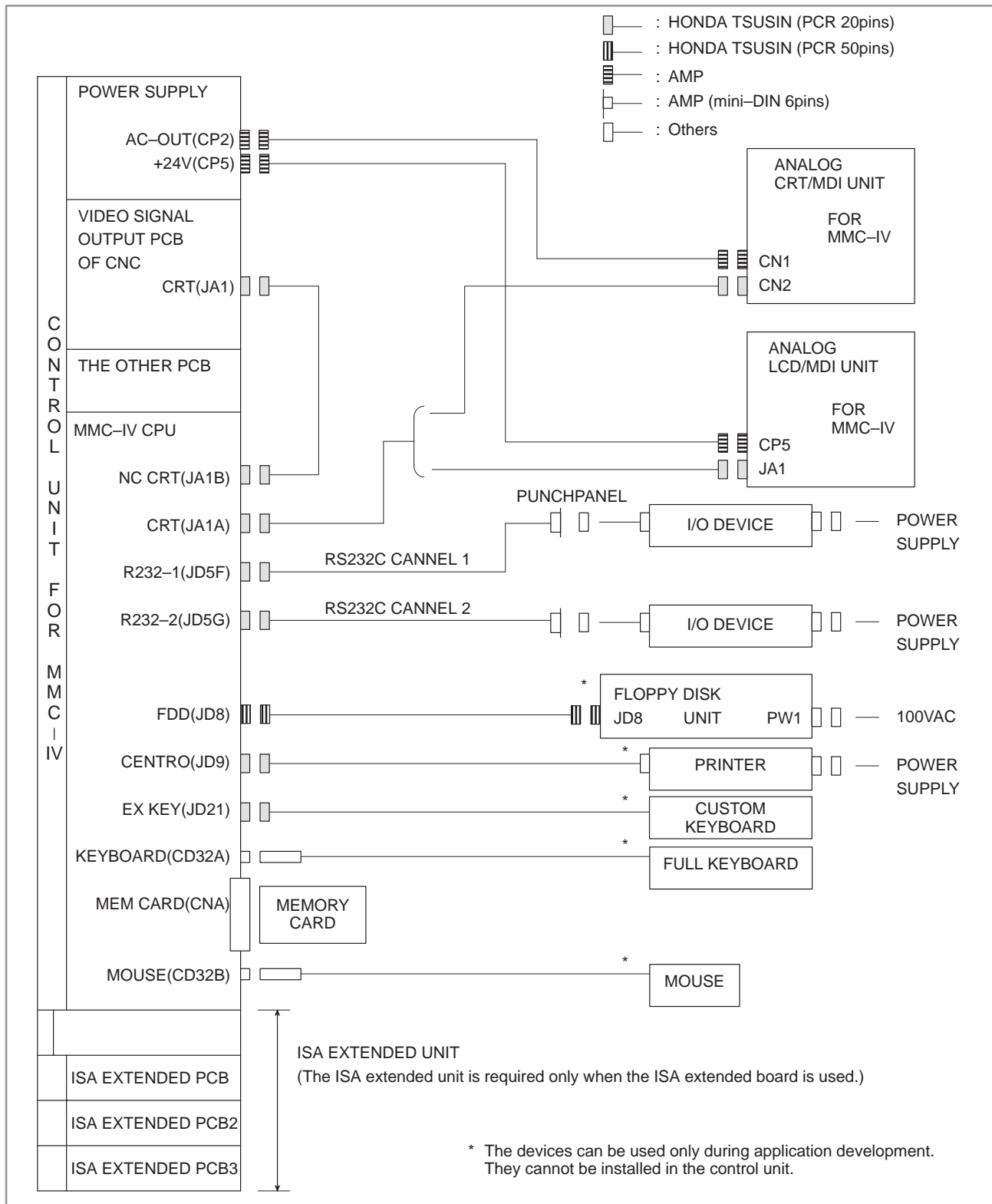

NOTE
MMC-IV can be used only with the Series 150-B.

2.4 INTER-MACHINE CONNECTION

2.4.1 CRT/MDI Unit

- Connection of Series 15-B

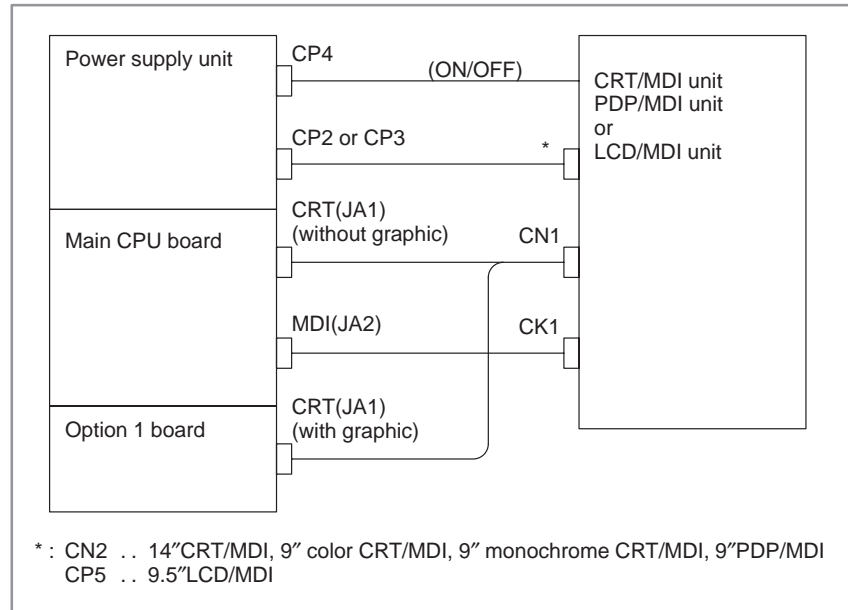

- Graphic function built-in type 10.4" LCD/MDI unit

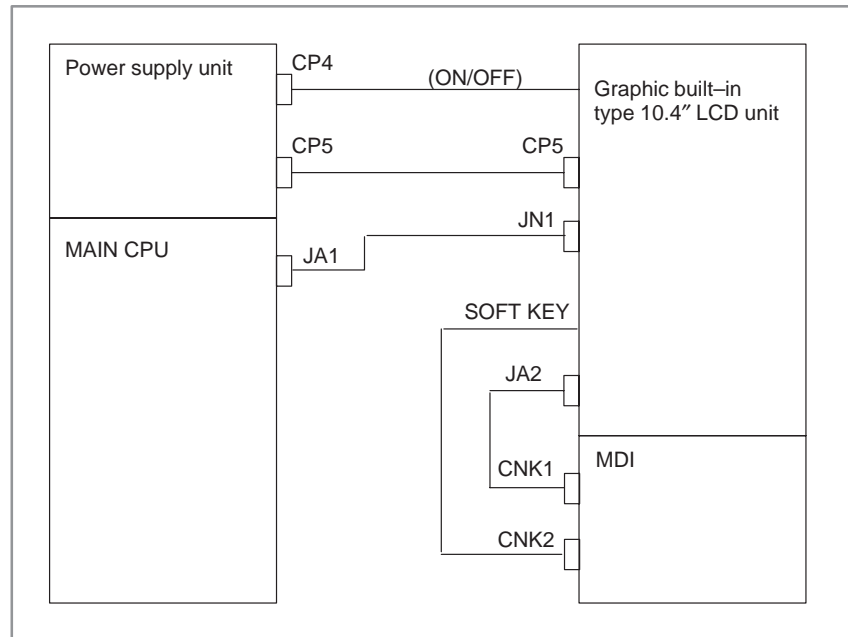

● **Terminal arrangement on the display power supply**

(For details, including connector information, refer to the “FANUC Series 15/150–MODEL B CONNECTION MANUAL (B-62073E).”

14" CRT/MDI, 9" color CRT/MDI, 9" PDP/MDI (200V type)

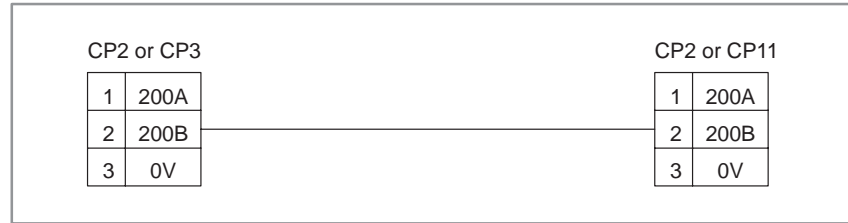

9" monochrome CRT/MDI



9.5"LCD/MDI, Graphic function built-in type 10.4"LCD, 10.4"LCD for MMC-IV

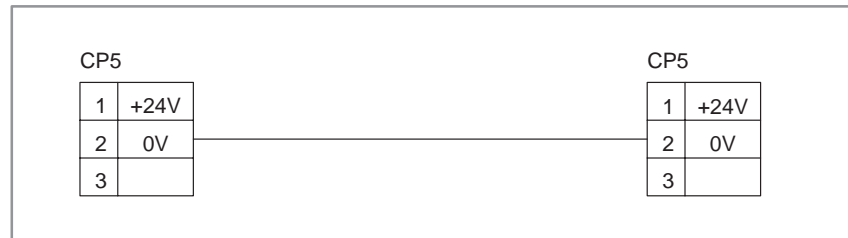

9" PDP/MDI (+24V type)

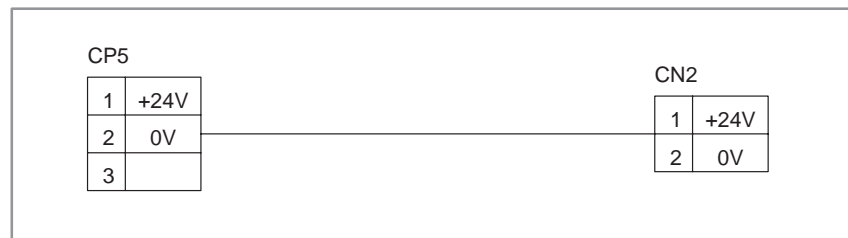

● Cable connection

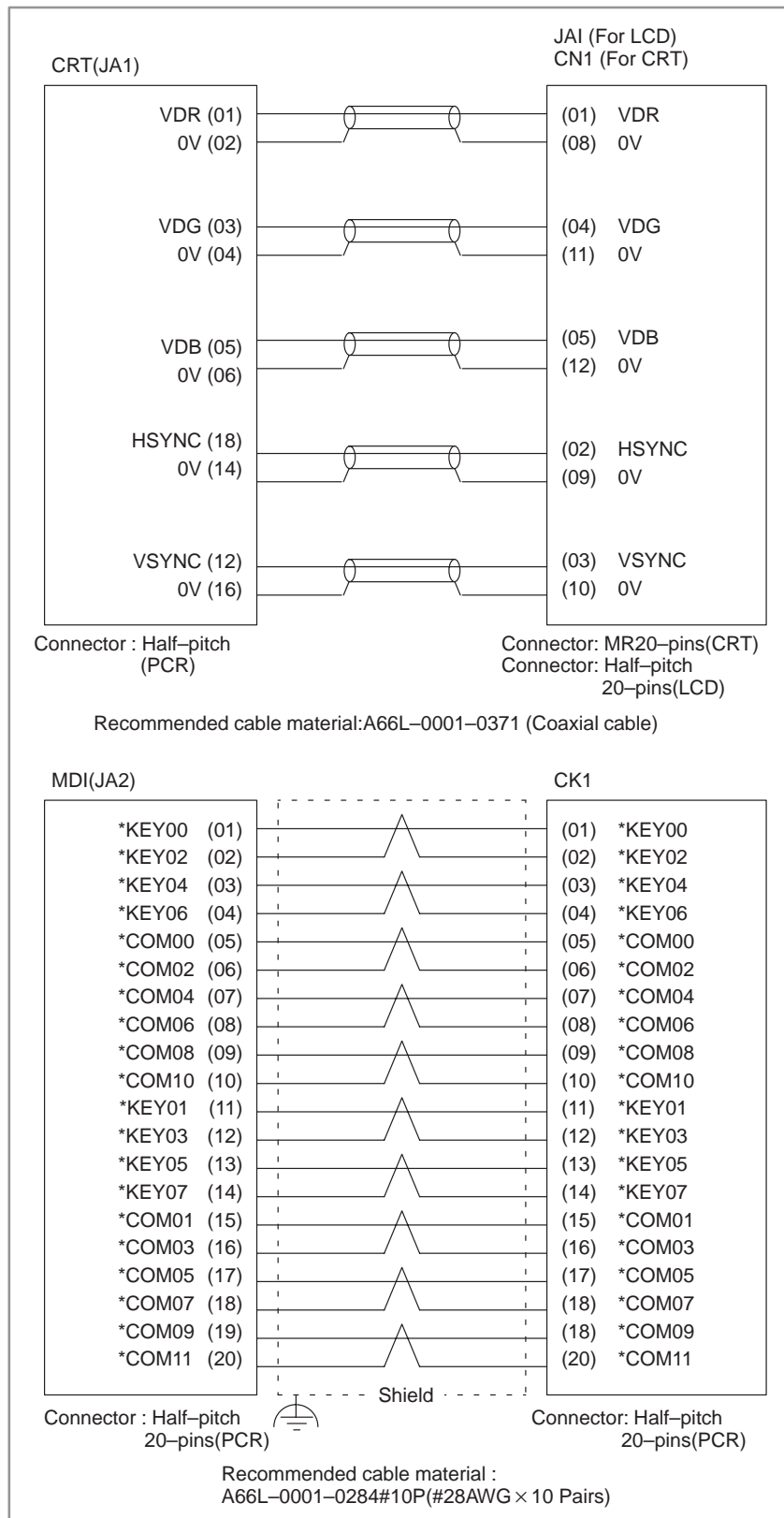

2.4.2 Reader/Puncher Interface

- Connection

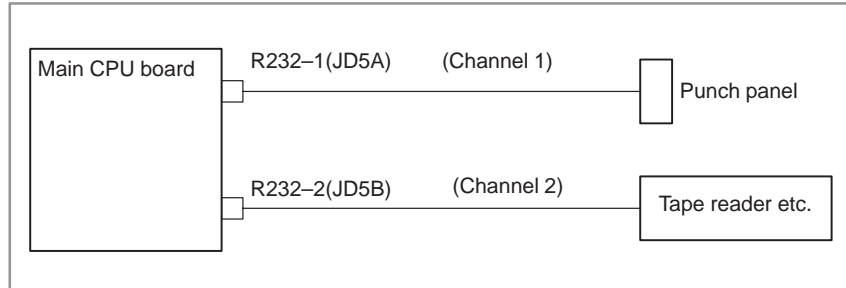

- Cable connection

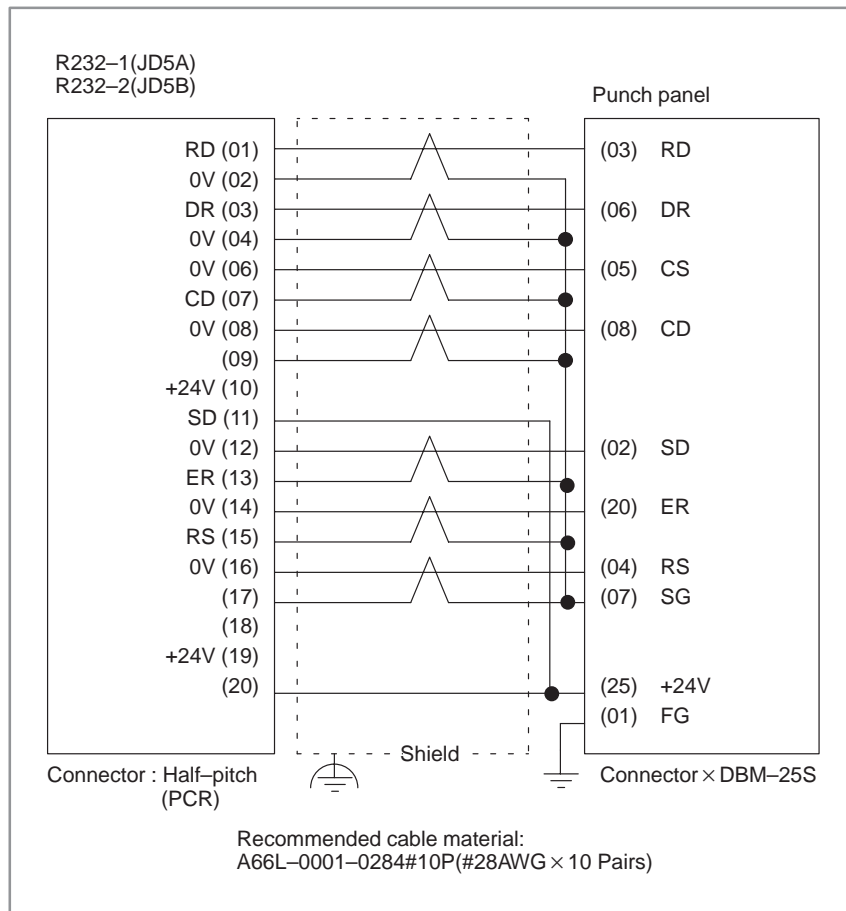

2.4.3 Manual Pulse Generator

- Connection

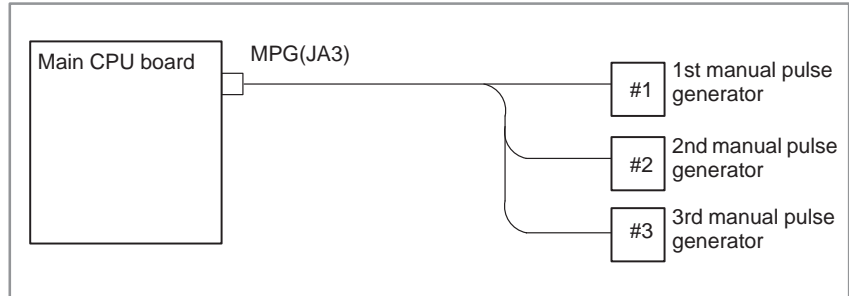

- Cable connection

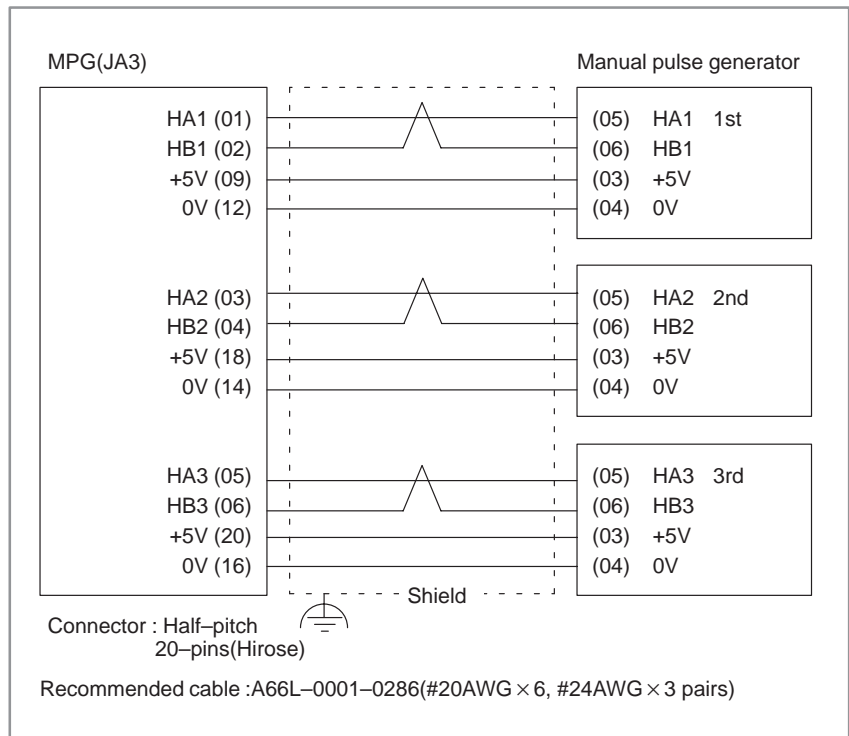

● **Voltage drop by cable length**

Restrict voltage drop by cable to less than 0.2V in accordance with +5V/0V.

$$\text{Voltage drop } V = \frac{A \times R \times 2L}{m}$$

Where A : manual pulse generator's current (0.1A)

R : Resistence per cable length

L : Cable length

m : No. of cables

When cable A66L-0001-0286 is used for one unit of manual pulse generator, resistence is 0.0394Ω/m and 3 cables are used. Therefore, cable length can be extended up to 50 m according to the following equation:

$$L = \frac{V \times m}{2A \times R} = \frac{0.2 \times 3}{2 \times 0.1 \times 0.0394} = 76.75[m]$$

2.4.4 I/O Link

● **Connection**

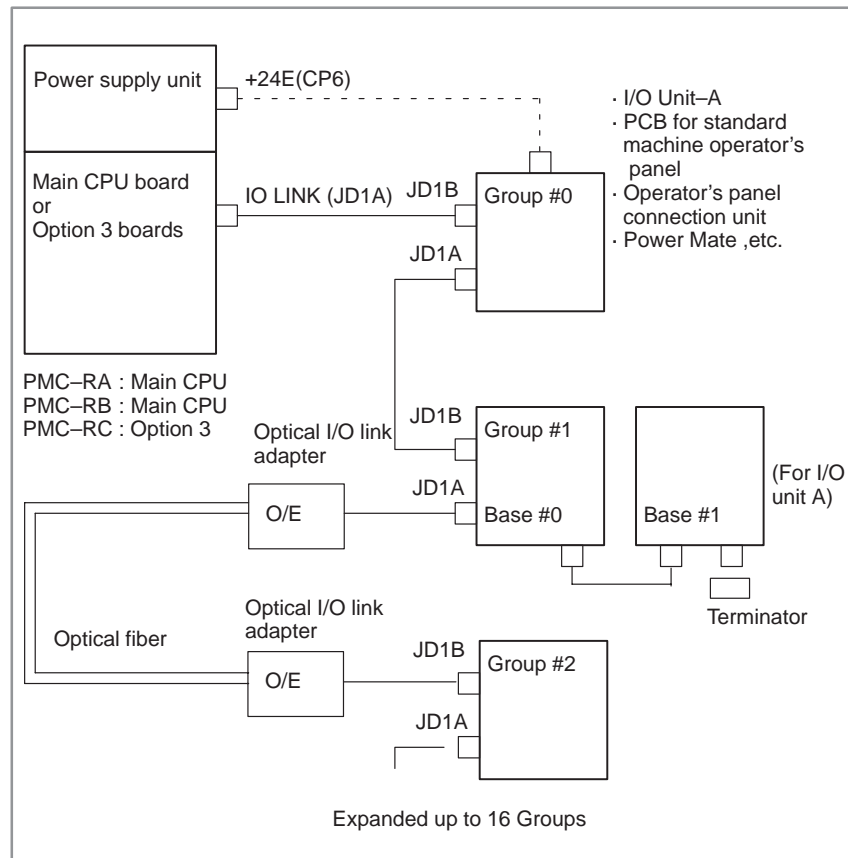

● **Cable connection within group**

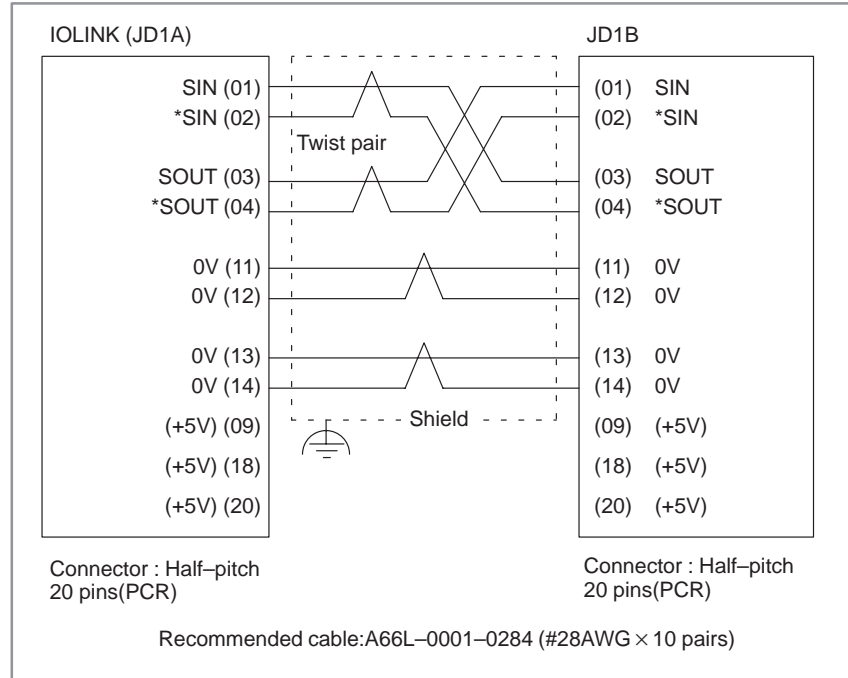

NOTE

Connect +5V when optical I/O link adapter is used. Do not connect when metal cable is used. When metal cable is used, cable length between units is extended by 10 m. When optical I/O link adapter is used, cable length between units is extended by 200m.

● **Connection between bases (with I/O unit-A)**

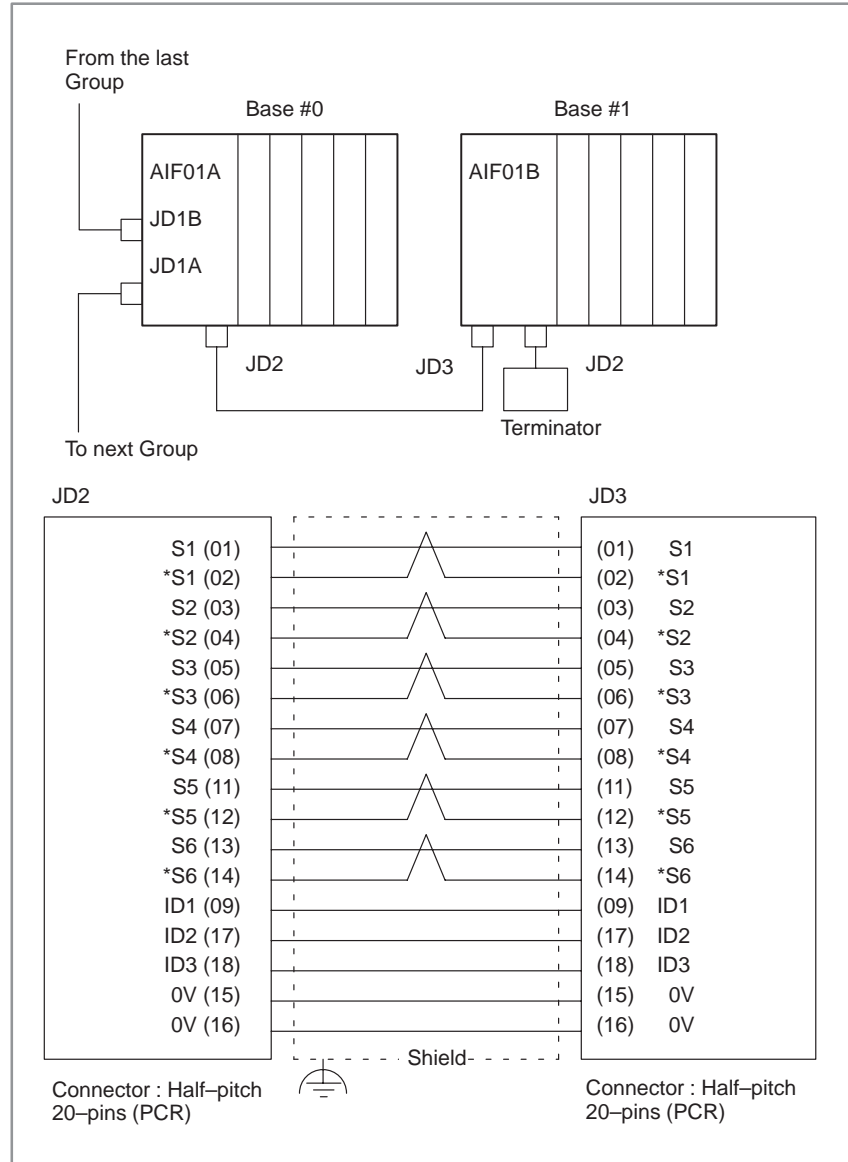

● **Cable connection in the terminator**

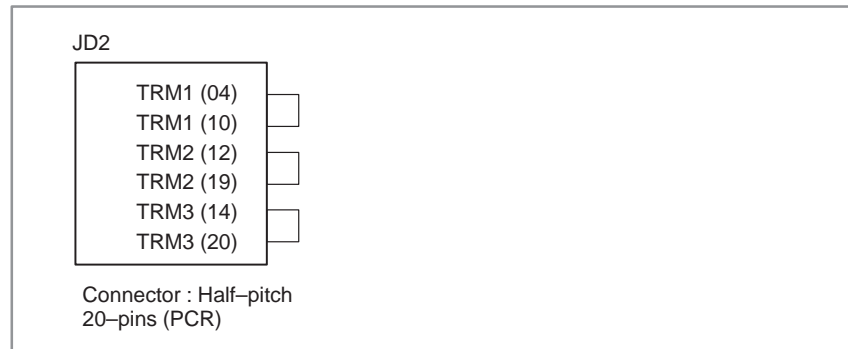

2.4.5 Servo Interface

• Connection

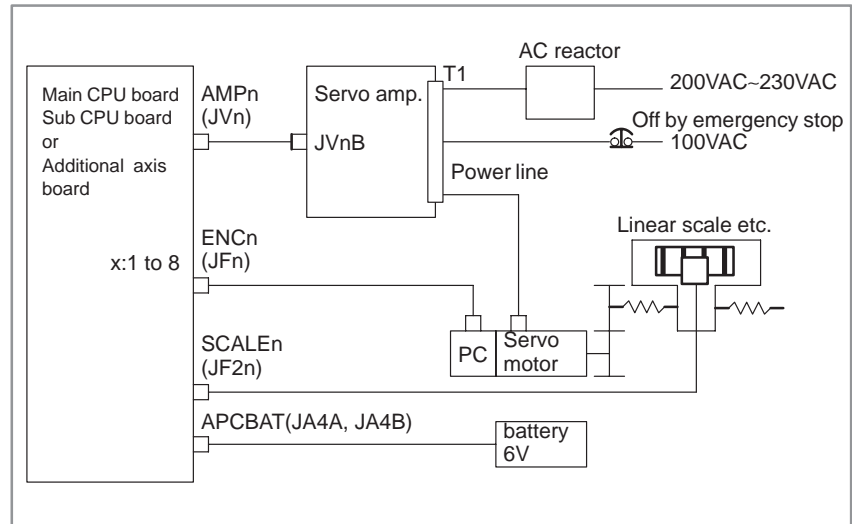

• Connection to α series servo amplifier

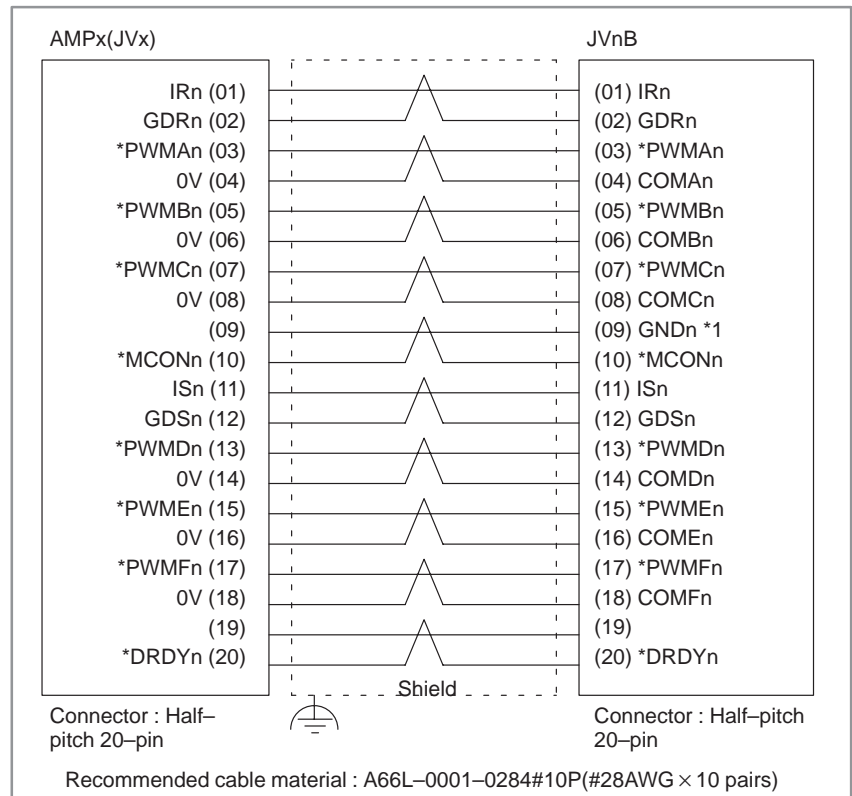

NOTE

- 1 Not used for α series amplifier.
- 2 Suffix n in signal name is an axis number 1 to 8.

● Connection of serial pulse coder

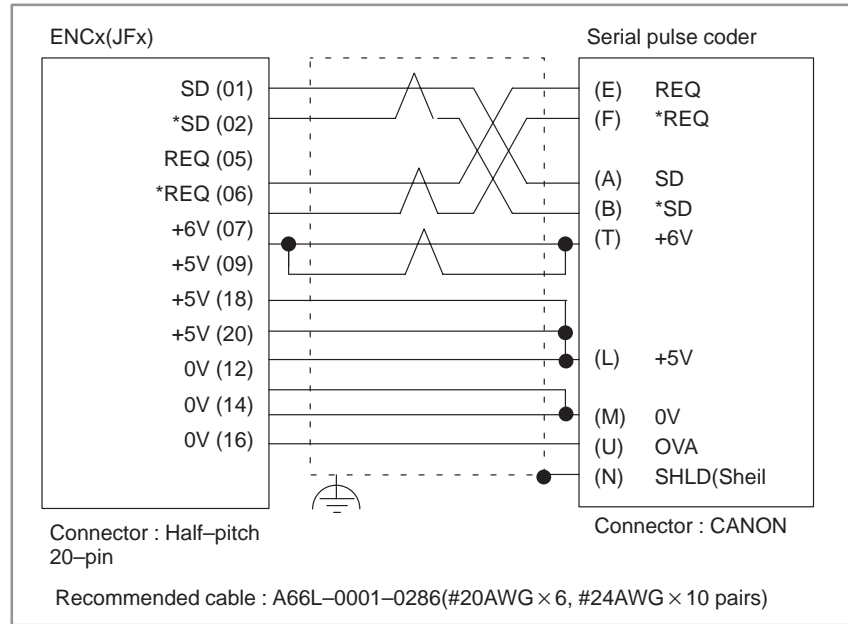

NOTE

Be sure to note voltage drop by cable resistance.

2.4.6 Connections by Type of Detectors

● Built-in pulse coder

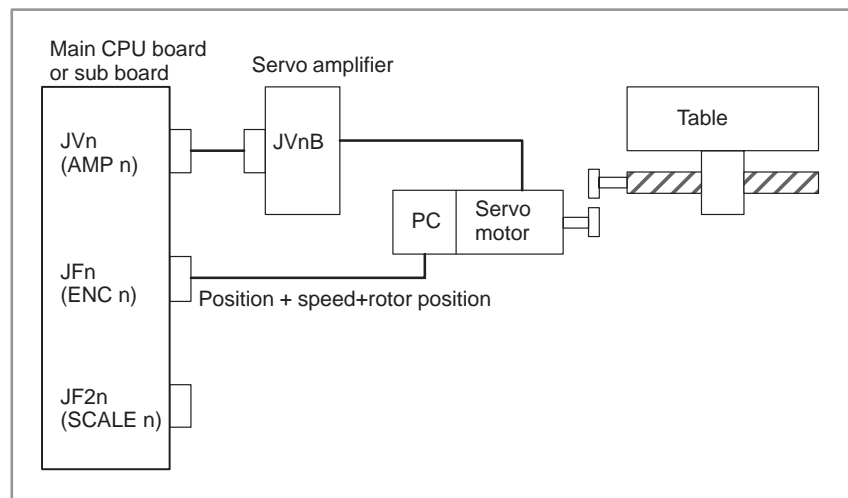

(n: 1 to 8. However, the sub-board is used when n = 4 to 8.)

• **Separate type pulse coder, Linear scale**

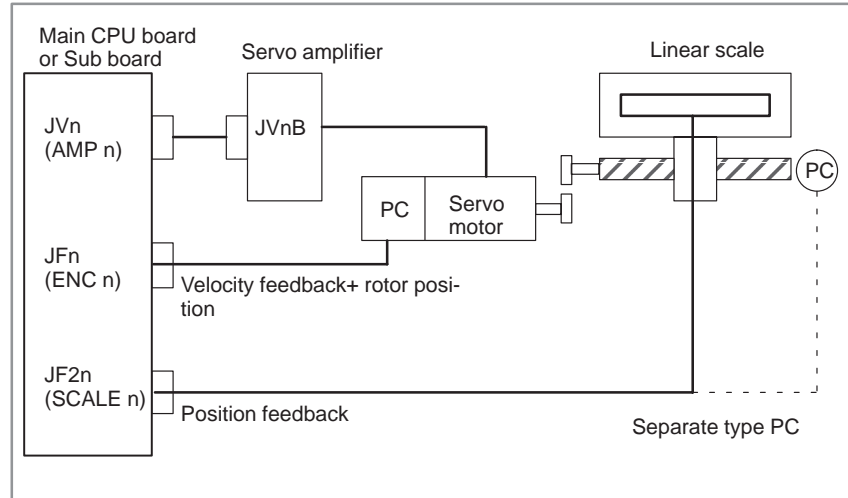

(n: 1 to 8. However, the sub-board is used when n = 4 to 8.)

	Cable for connecting between the main CPU board to the servo amplifier	When a built-in pulse coder is used	When a separate pulse coder or linear scale is used	
			Feedback cable connected to the motor	Cable connected to the separate pulse coder
1st axis	AMP1	ENC1	ENC1	SCALE1
2nd axis	AMP2	ENC2	ENC2	SCALE2
3rd axis	AMP3	ENC3	ENC3	SCALE3
4th axis	AMP4	ENC4	ENC4	SCALE4

2.4.7 Combining Serial Spindle and Analog Spindle

- Only serial spindle is used

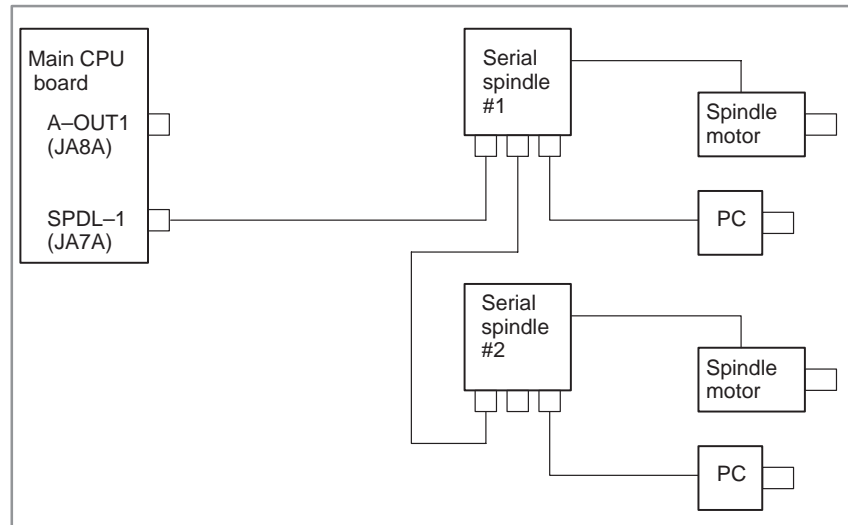

- Only analog spindle is used

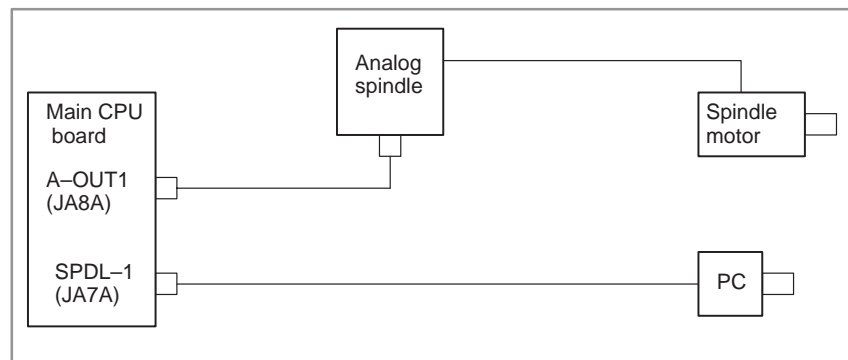

2.4.8 Connection to α Serial Spindle Amplifier

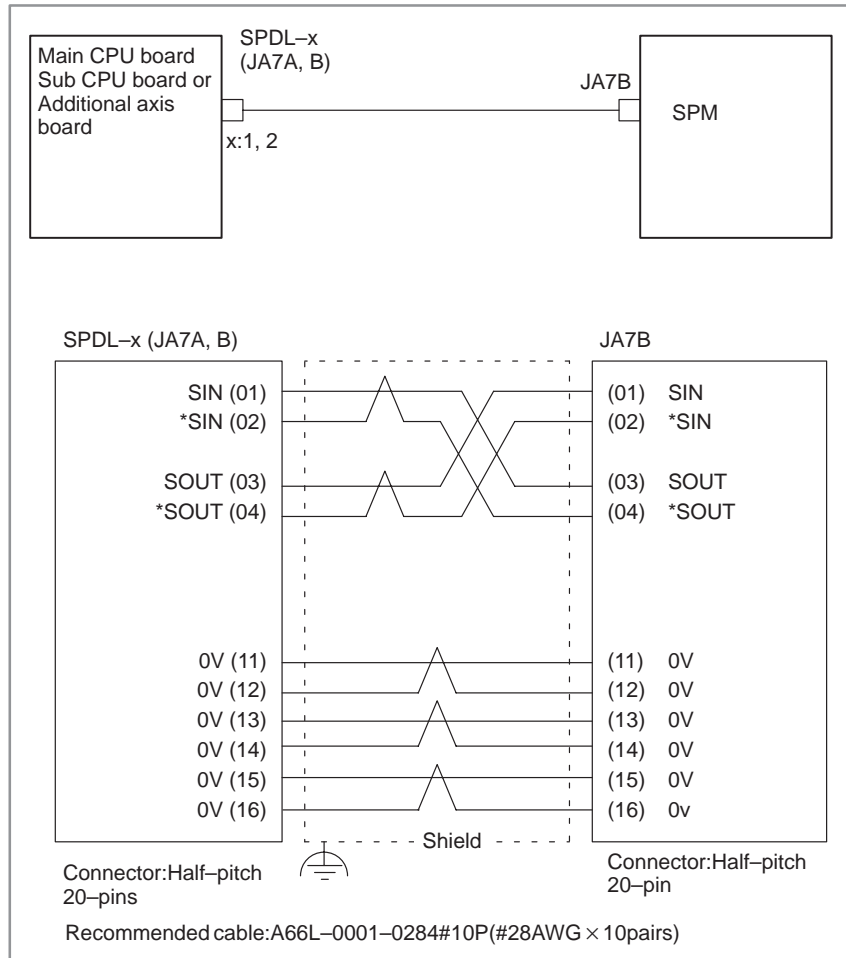

2.4.9 Connection to Analog Spindle Amplifier

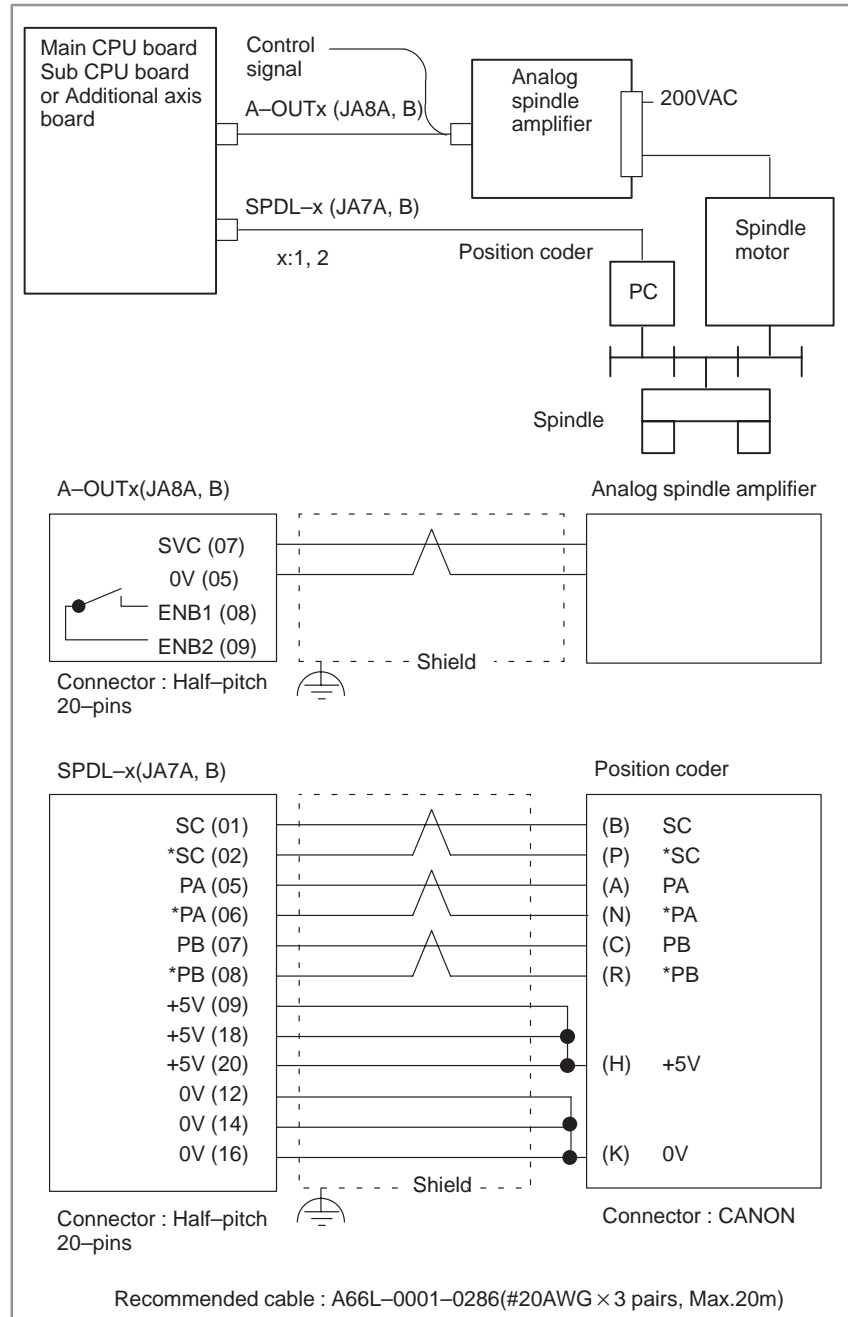

2.4.10 Remote Buffer Interface

- Connection

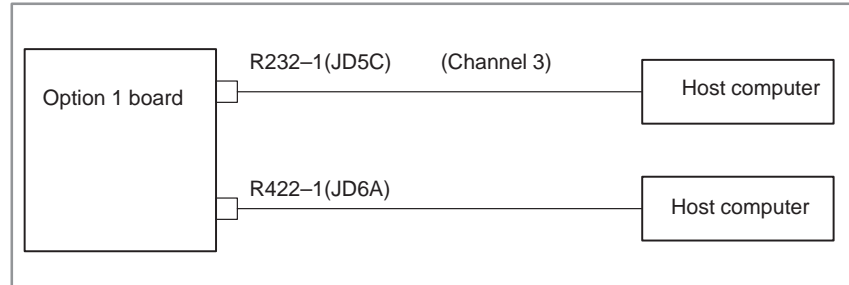

- Example of cable connection

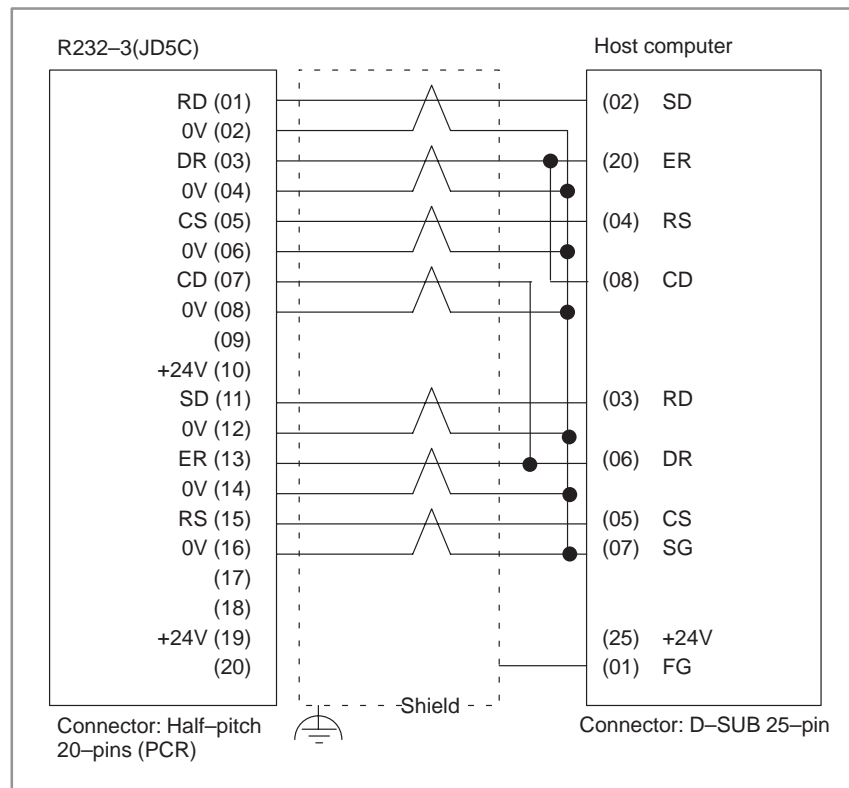

NOTE

- 1 Connect RS when CS is not used.
- 2 Connect as follows when protocol A or extended protocol A is used:
 - a) Connect to ER when DR is not used.
 - b) Always connect CD to ER

● Example of RS-422 cable

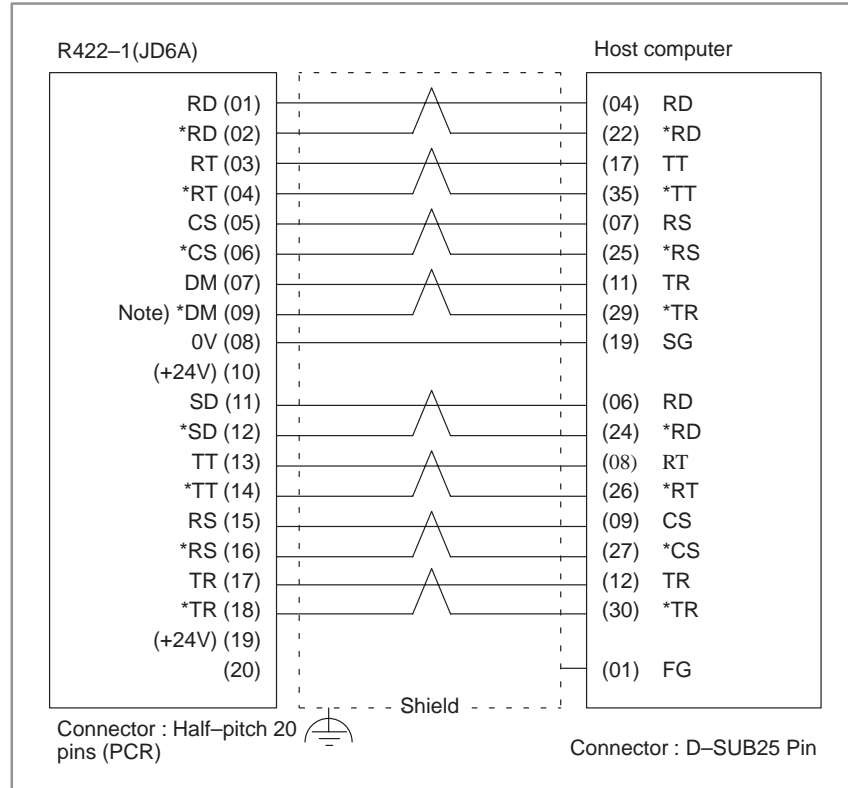

NOTE

Be sure to use the twisted pair cable. Note that pin arrangement of *DM signal on NC side is not regular to escape from damage due to wrong connection.

2.4.11 High-speed DI Signal Interface

- Connection diagram

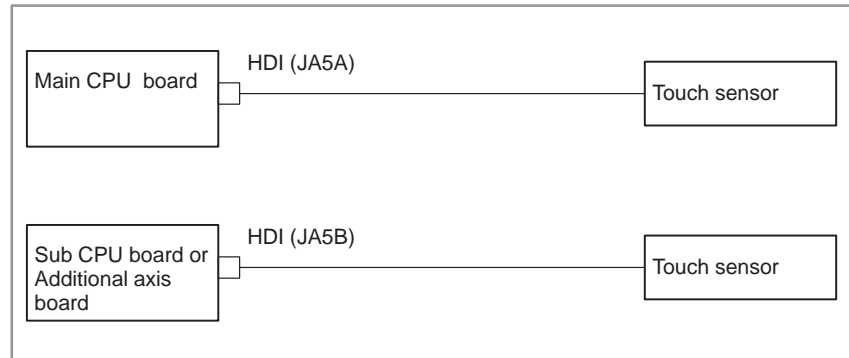

- Connection details

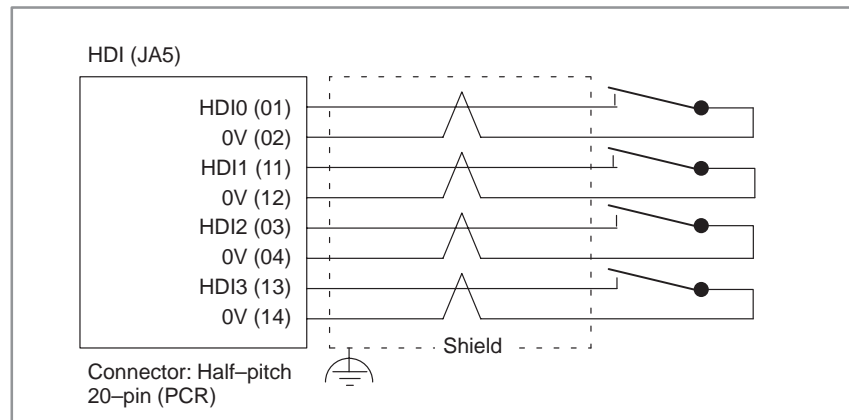

2.4.12 Environmental Requirement

The peripheral units, such as the control unit and CRT/MDI, have been designed on the assumption that they are housed in closed cabinets. In this manual “cabinet” refers to the following:

- (1) Cabinet manufactured by the machine tool builder for housing the control unit or peripheral units;
- (2) Cabinet for housing the flexible turnkey system provided by FANUC;
- (3) Operation pendant, manufactured by the machine tool builder, for housing the CRT/MDI unit or operator’s panel ;
- (4) Equivalent to the above.

The environmental conditions when installing these cabinets shall conform to the following table.

Ambient temperature	Operating Ambient temperature outside the cabinet: +0 °C to +45°C Ambient temperature inside the cabinet: 0°C to +55°C (+5°C to +50°C for MMC-IV) Storage or transportation -20°C to +60°C
Temperature change rate	Allowable temperature change rate $\leq 1.1^\circ\text{C}$ per minute
Humidity	Relative humidity: 30% to 95% (no condensation)
Altitude	No more than 2000 m above sea level
Vibration	Operating: 0.5 G or less
Atmosphere	Environment outside the cabinet: Special consideration is required when cabinets are used in an environment exposed to relatively high levels of contaminants (dust, coolant, organic solvent, acid, corrosive gas, salt, and so forth). Environment inside the cabinet: Ensure that the equipment housed in the cabinet is exposed to those contaminants described above. Radiation fins, fans, and so forth outside the cabinet: Ensure that these components are not directly exposed to coolant, lubricant, or chips.
Ionizing radiation and non-ionizing radiation	When a cabinet is used in an environment exposed to radiation (microwaves, ultraviolet rays, laser beams, X rays, and so forth), take protective measures.

2.4.13 Power Capacity

The power capacity of the CNC control unit, which in this section means the specification required for the power supply, is obtained by adding the power capacity of the control section and the power capacity of the servo section.

Power capacity of the control section	When the control unit has four slots or less, and power supply AI is used.	0.4KVA
	When the control unit has six or more slots, or power supply BI is used.	1KVA
	When the multiple axis is used.	2KVA
Power capacity of the servo section	Depends on servo motor type.	

2.4.14 Action Against Noise

The CNC has been steadily reduced in size using surface-mount and custom LSI technologies for electronic components. The CNC also is designed to be protected from external noise. However, it is difficult to measure the level and frequency of noise quantitatively, and noise has many uncertain factors. It is important to prevent both noise from being generated and generated noise from being introduced into the CNC. This precaution improves the stability of the CNC machine tool system.

The CNC component units are often installed close to the parts generating noise in the power magnetism cabinet. Possible noise sources into the CNC are capacitive coupling, electromagnetic induction, and ground loops.

When designing the power magnetism cabinet, guard against noise in the machine as described in the following:

- **Separating signal lines**

The cables used for the CNC machine tool are classified as listed in the following table :

Bind the cables in each group as described in the action column.

Group	Signal line	Action
A	Primary AC power line	Bind the cables in group A separately (Caution 1) from groups B and C or cover group A with an electromagnetic shield (Caution 2). Connect spark killers or diodes with the solenoid and relay.
	Secondary AC power line	
	AC/DC power lines (containing the power lines for the servo and spindle motors)	
	AC/DC solenoid	
	AC/DC relay	
B	DC solenoid (24VDC)	Connect diodes with DC solenoid and relay. Bind the cables in group B separately from group A or cover group B with an electromagnetic shield. Separate group B as far from group C as possible. It is more desirable to cover group B with the shield.
	DC relay (24 VDC)	
	DI/DO cable between the CNC and power magnetics cabinet	
	DI/DO cable between the CNC and machine	
C	Cable between the CNC and servo amplifier	Bind the cables in group C separately from group A or cover group C with an electromagnetic shield. Separate group C as far from group B as possible. Be sure to perform shield processing
	Cable for position and velocity feedback	
	Cable between the CNC and spindle amplifier	
	Cable for the position coder	
	Cable for the manual pulse generator	
	Cable between the CRT and MDI	
	RS232C and RS422 interface cables	
	Cable for the battery	
	Other cables to be covered with the shield	

CAUTION

- 1 The groups must be 10 cm or more apart from one another when binding the cables in each group.
- 2 The electromagnetic shield refers to shielding between groups with grounded steel plates.

• Ground

The following ground systems are provided for the CNC machined tool:

1. Signal ground system (SG)

The signal ground (SG) supplies the reference voltage (0V) of the electrical signal system to the machine.

2. Frame ground system (FG)

The frame ground system (FG) is used for safety, and suppressing external and internal noises. In the frame ground system, the frames and cases of the units, panels, and shields for the interface cables between the units are connected.

3. System ground system

The system ground system is used to connect the frame ground systems connected between devices or units with the ground.

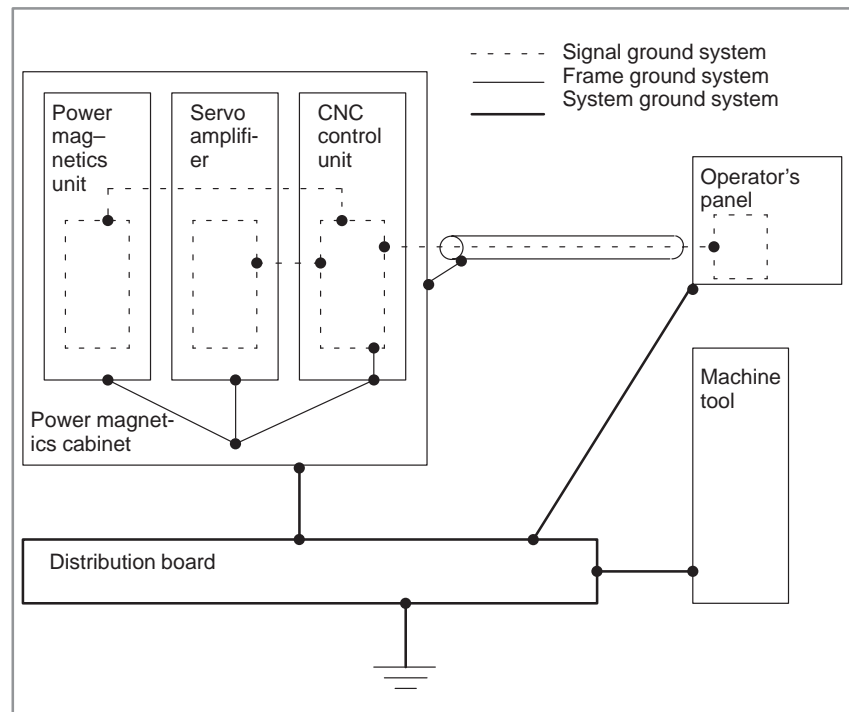

Notes on connecting the ground systems

- Connect the signal ground with the frame ground (FG) at only one place in the CNC control unit.
- The grounding resistance of the system ground shall be 100 ohms or less (class 3 grounding).
- The system ground cable must have enough cross-sectional area to safely carry the accidental current flow into the system ground when an accident such as a short circuit occurs.
(Generally, it must have the cross-sectional area of the AC power cable or more.)
- Use the cable containing the AC power wire and the system ground wire so that power is supplied with the ground wire connected.

- **Connecting the signal ground (SG) of the control unit**

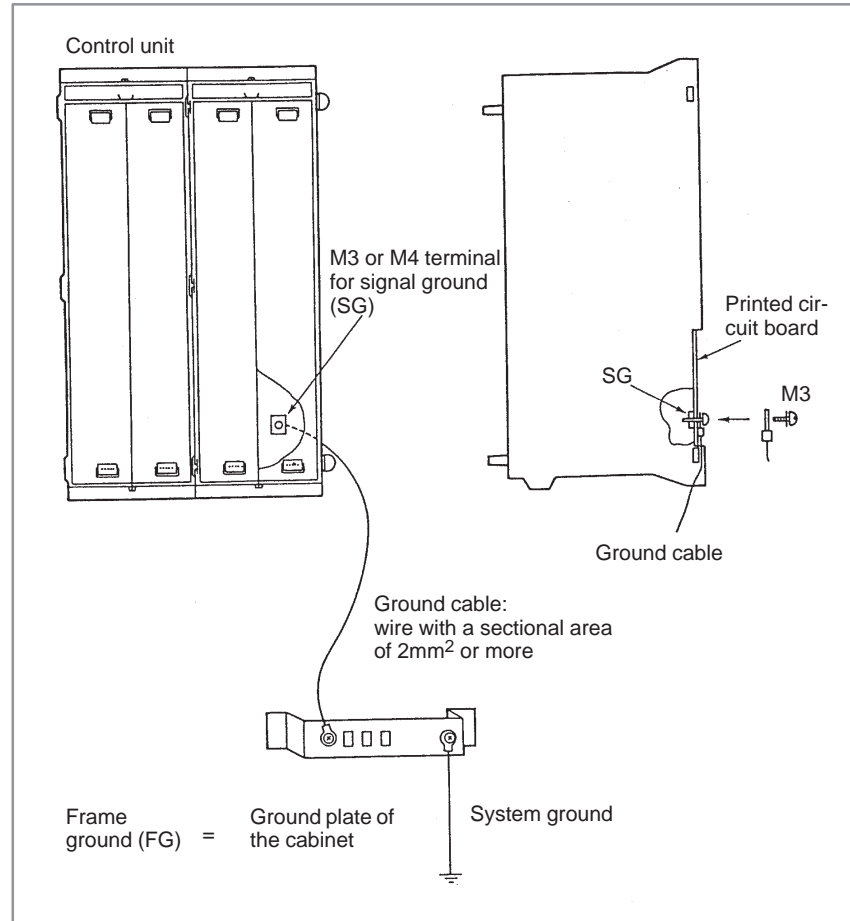

Connect the 0 V line of the electronic circuit in the control unit with the ground plate of the cabinet via the signal ground (SG) terminal. The SG terminal is located on the printed circuit board at the rear of the control unit.

● **Noise suppressor**

The AC/DC solenoid and relay are used in the power magnetics cabinet. A high pulse voltage is caused by coil inductance when these devices are turned on or off.

This pulse voltage induced through the cable causes the electronic circuits to be disturbed.

To reduce the pulse voltage, use a spark killer for an AC device or a diode for a DC device.

Notes on selecting the spark killer

Use a spark killer consisting of a resistor and capacitor in series. This type of spark killer is called a CR spark killer.

(A varistor is useful in clamping the peak voltage of the pulse voltage, but cannot suppress the sudden rise of the pulse voltage. FANUC therefore recommends a CR spark killer.)

The reference capacitance and resistance of the spark killer shall conform to the following based on the current (1(A)) and DC resistance of the stationary coil :

- 1) Resistance (R):Equivalent to DC resistance of the coil
- 2) Capacitance (C): $\frac{I^2}{10} \sim \frac{I^2}{20} (\mu F)$

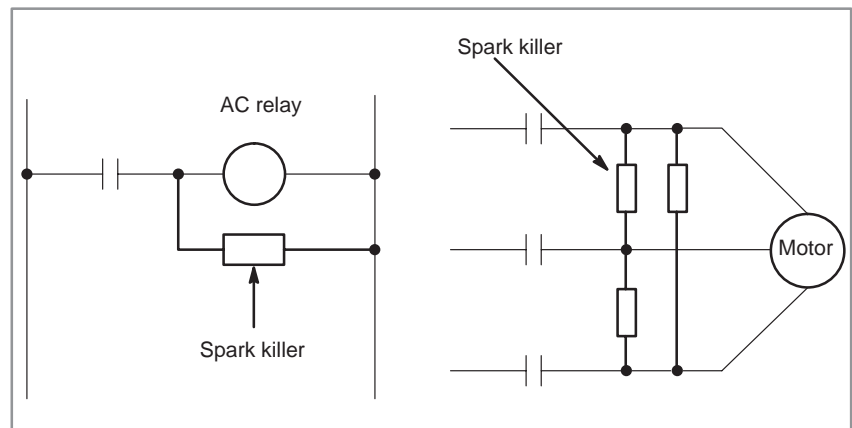

- **Cable clamp and shield processing**

The CNC cables that required shielding should be clamped by the method shown below. This cable clamp treatment is for both cable support and proper grounding of the shield. To insure stable CNC system operation, follow this cable clamp method.

Partially peel out the sheath and expose the shield. Push and clamp by the plate metal fittings for clamp at the part. Metal fittings for clamp are attached to the control unit. The ground plate must be made by the machine tool builder, and set as follows:

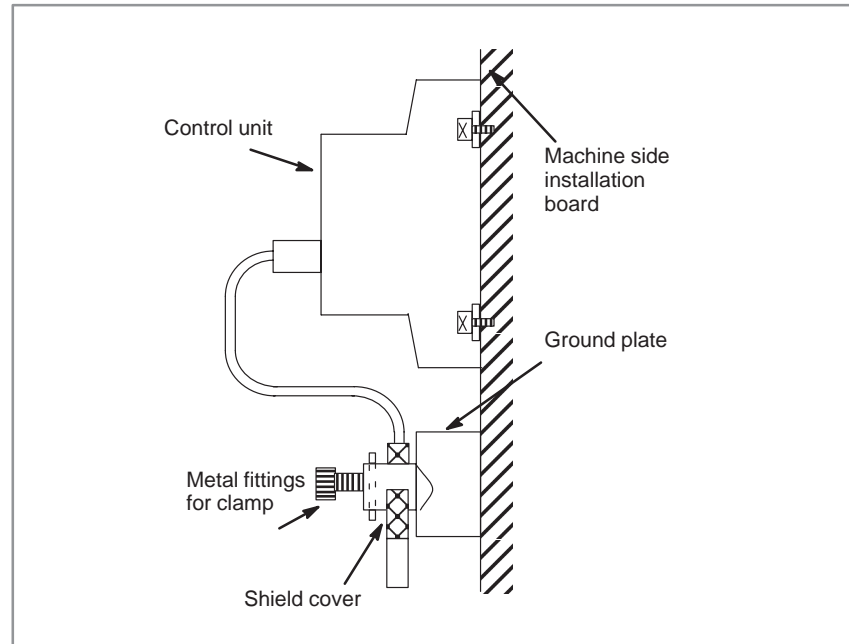

Use a cable of the appropriate length. A cable that is longer than necessary is undesirable because immunity to noise is likely to degrade and the cable may induce noise on another cable. If the excess length of cable is coiled, increased inductance will result. Such an increased inductance may induce a very high voltage when a signal is turned on or off, and could cause a failure or noise-based malfunction.

2.5 LIGHTING OF ALARM LEDS ON PCBS

If an alarm condition occurs, an alarm message is usually displayed on the CRT screen. The state of the PCB when the alarm occurred is indicated by the LEDs on the front panel of each control unit PCBs, as shown below.

When a system alarm occurs, the alarm message displayed on the screen, together with the LED indications on each PCB, help you to determine the cause. Record the LED indications for each PCB to enable rapid recovery of the system.

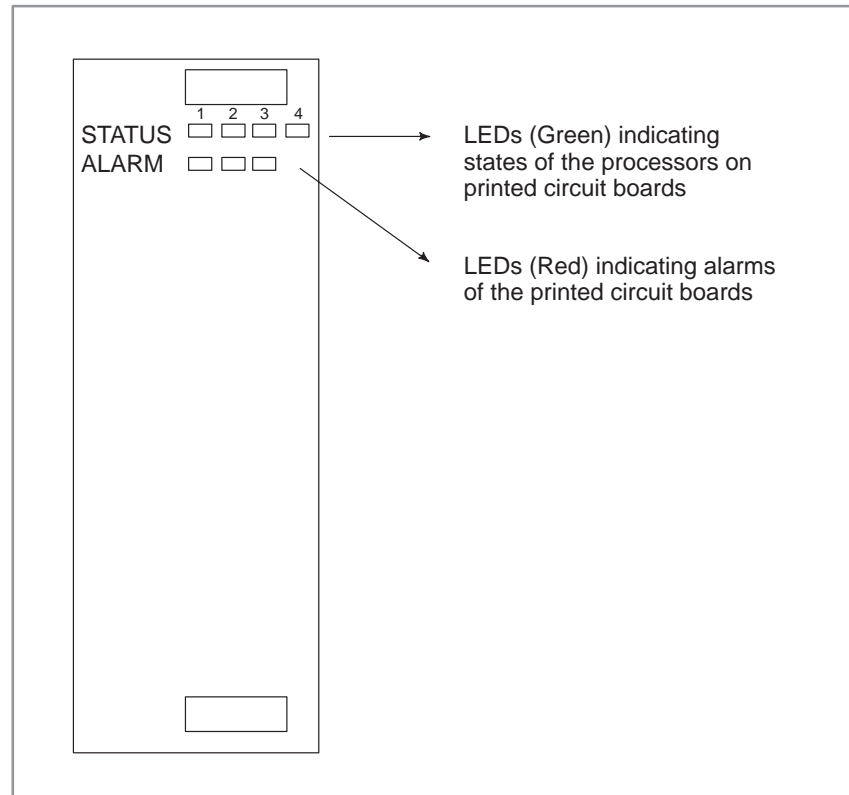

Fig. 2.5 LED display for the printed circuit boards in the control unit

2.5.1 Configuration of the Power Supply Unit

Name	Code	Remarks
Power supply unit A1	A16B-1212-0471	Conventional type
	A16B-1212-0901	CE marking compatible type
Power supply unit B1	A16B-1212-0531	Conventional type
	A16B-1212-0871	CE marking compatible type

- LED display

PIL (Green)	This LED is lit when the input AC power voltage is supplied to CP1.
ALM (Red)	This LED is lit when overcurrent, overvoltage, or low voltage occurs in direct current output voltage.

● Disposition of Connector, etc.

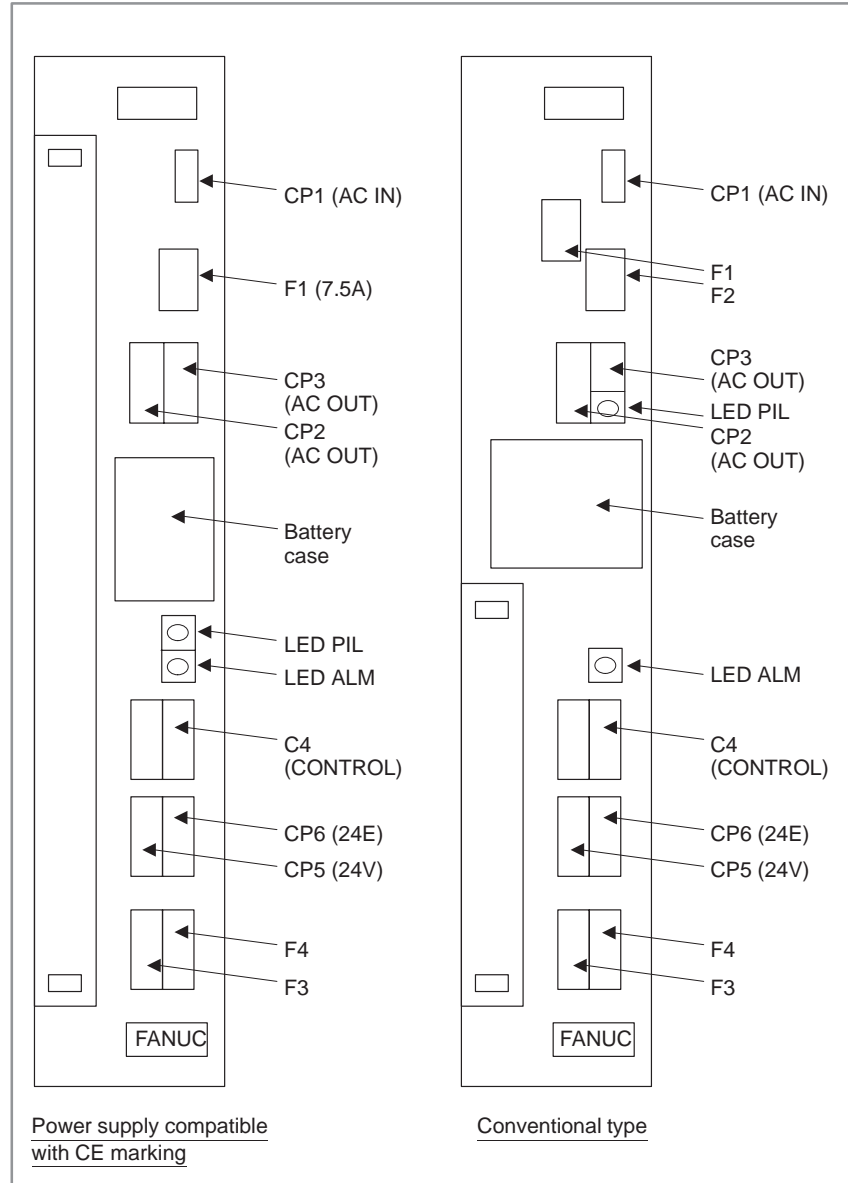

- Fuse

List of fuses (Conventional type)

Power supply	Ordering drawing number	Symbol	Rating	Specification	Application
AI	A02B-0120-K102	F1	7.5A	A60L-0001-0245#GP75	For a 200-VAC input power supply
		F2	7.5A	A60L-0001-0245#GP75	For a 200-VAC input power supply
		F3	3.2A	A60L-0001-0075#3.2	24-V indicator, main CPU, +24V for optional PC boards
		F4	5AS	A60L-0001-0046#5.0	Protection of the machine-side +24E line from external failures
		F5	0.3A	A60L-0001-0290#LM03	Inside the power supply unit
BI	A02B-0120-K103	F1	10A	A60L-0001-0245#GP100	For a 200-VAC input power supply
		F2	10A	A60L-0001-0245#GP100	For a 200-VAC input power supply
		F3	5A	A60L-0001-0075#5.0	24-V indicator, main CPU, +24V for optional PC boards
		F4	5AS	A60L-0001-0046#5.0	Protection of the machine-side +24E line from external failures
		F5	0.3A	A60L-0001-0290#LM03	Inside the power supply unit

List of fuses (CE Marking compatible type)

Power supply	Ordering drawing number	Symbol	Rating	Specification	Application
AI	A02B-0200-K100	F1	7.5A	A60L-0001-0245#GP75	For the 200-VAC input power supply
		F3	3.2A	A60L-0001-0075#3.2	24-V indicator, main CPU, +24V for optional PC boards
		F4	5AS	A60L-0001-0046#5.0	Protection of the machine-side +24E line from external failures
BI	A02B-0200-K101	F1	7.5A	A60L-0001-0245#GP100	For the 200-VAC input power supply
		F3	5A	A60L-0001-0075#5.0	24-V indicator, main CPU, +24V for optional PC boards
		F4	5AS	A60L-0001-0046#5.0	Protection of the machine-side +24E line from external failures

● **Battery**

Ordering drawing number	Specification	Remarks
A02B-0120-K106	A98L-0031-0007	Battery for conventional power supply
A02B-0200-K103	A98L-0031-0012	Battery for power supply compatible with CE marking

● **Block diagram**

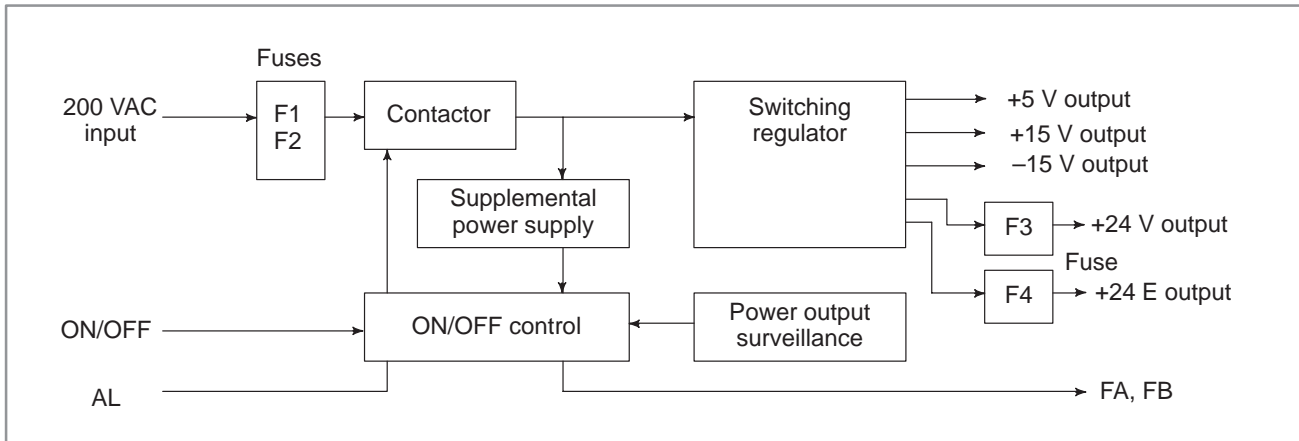

Fig. 2.5.1 Power unit block diagram

● **Adjustment**

No adjustment is needed.

2.5.2 Configuration of the CPU Board (MAIN-B)

(1) Parts layout

Drawing number : A16B-2201-0320

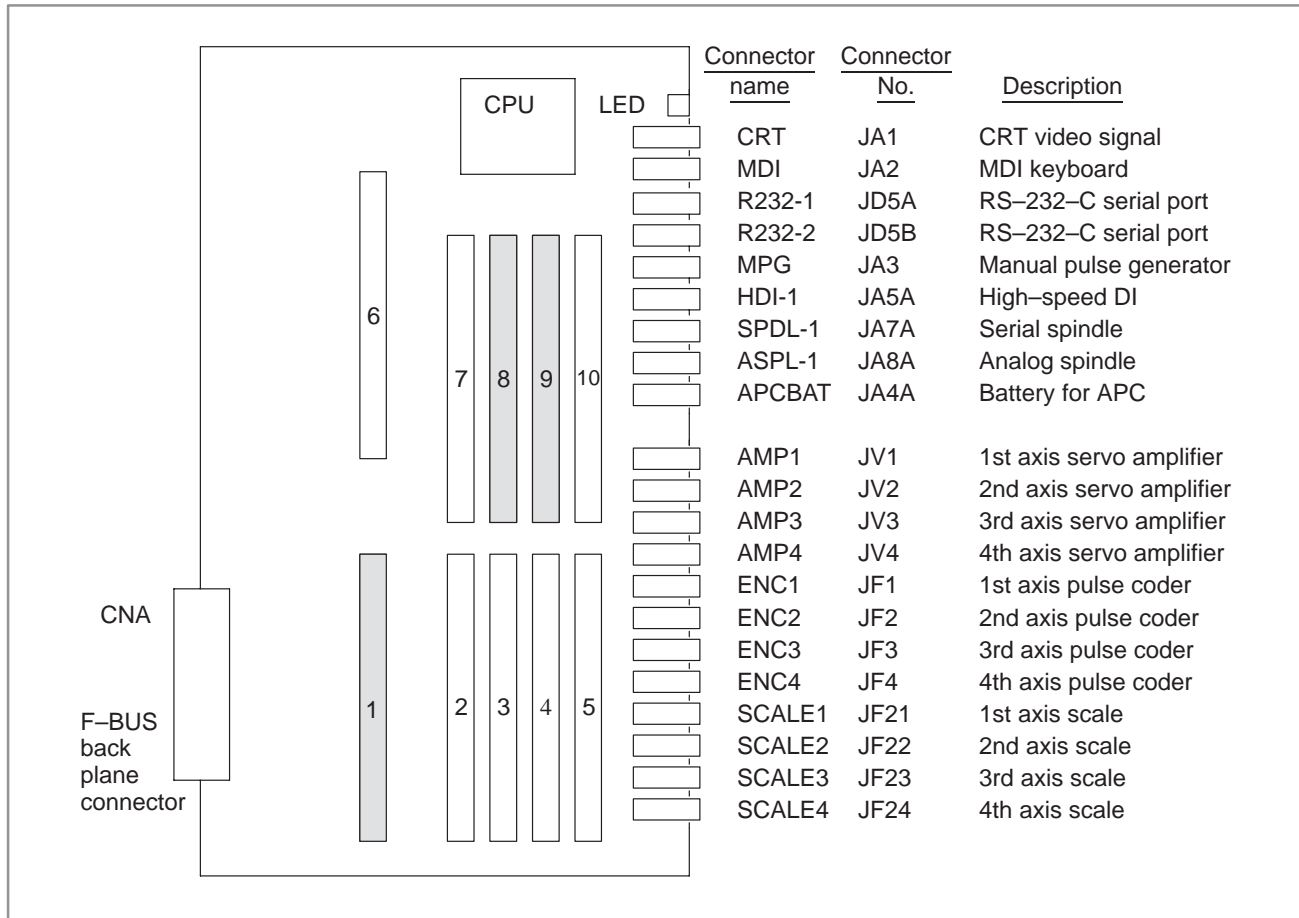



No.	Module name	Function outline
1	SRAM module	Part programs storage, RAM for parameter
2	Servo control module	3rd and 4th servo control
3	Servo control module	1st and 2nd servo control
4	Servo interface module	3rd and 4th amplifier, pulse coder interface
5	Servo interface module	1st and 2nd amplifier, pulse coder interface
6	DRAM module	RAM for CNC system
7	FLASH ROM module	FLASH-EPROM for CNC system
8	Spindle control module	System clear, battery backup control, spindle control, HDI interface etc....
9	Peripheral module	MDI, MPG, RS-232C, etc.... System timer, system clock, calendar clock
10	CRT control module	CRT display control

WARNING

means the module connected power supply for battery backup. If the module are taken away carelessly, the backup are lost.

NOTE

If a peripheral module is replaced, the time indicator may be disabled. In such a case, turn off the CNC. Then, turn on the CNC while holding down both the  key and  key on the MDI keyboard. Keep the two keys held down until the position screen is displayed. Then, the time indicator will resume normal operation.

(2) Block diagram

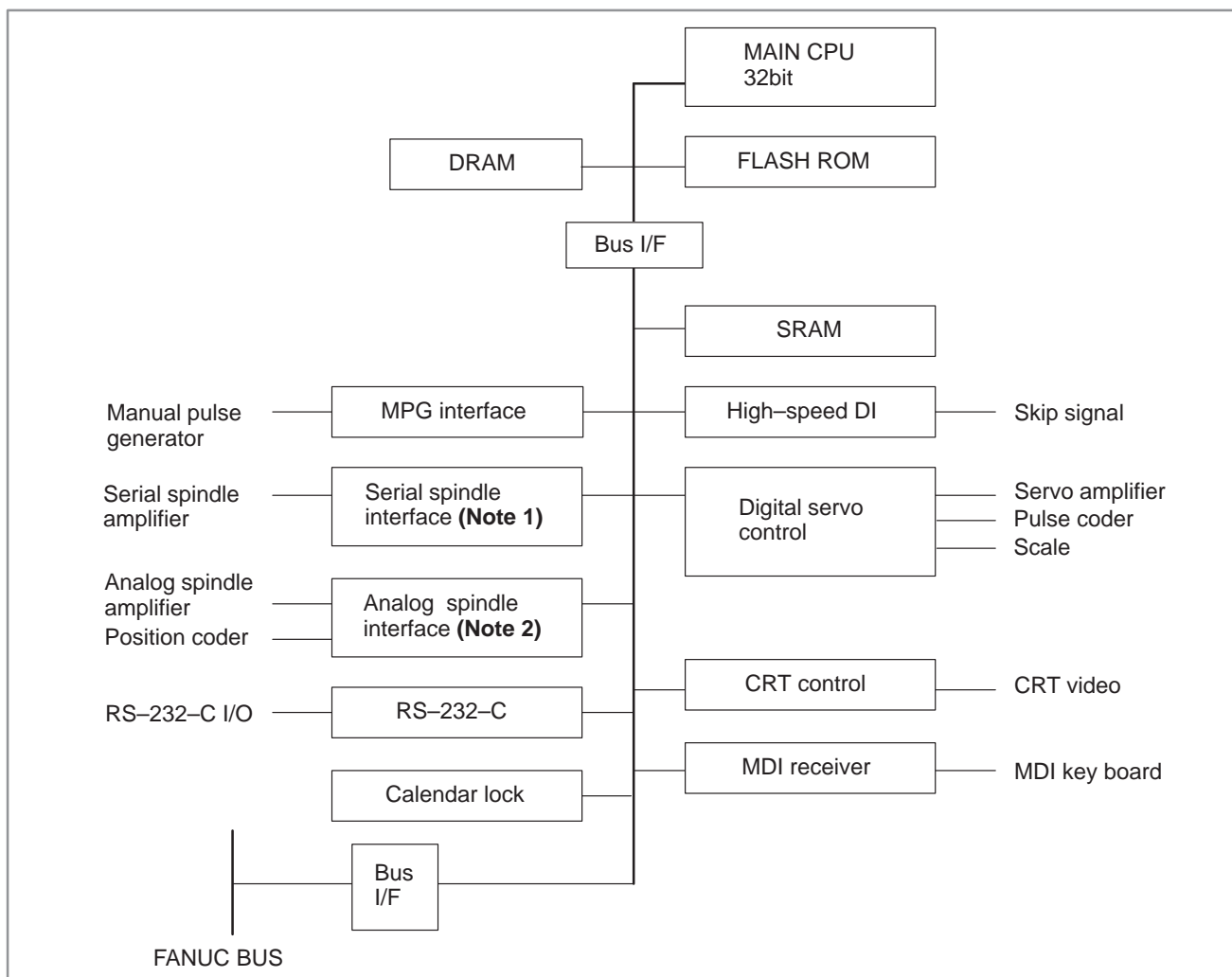
**NOTE**

- 1 When the module of analog spindle is built in as a module of spindle control, the series interface is not there.
- 2 When a serial spindle module is mounted as the spindle control module, an analog spindle interface is not used.

(3) Adjustment

No adjustment is needed.

(4) LED display

□ : off ■ : Lit ★ : Flashing

1. LED display transition when the power is turned on

No.	LED display	NC status
1	STATUS □□□□	Power-off
2	STATUS ■■■■	Initial state immediately after power-on
3	STATUS ■□□■	Beginning of activation of the CNC software
4	STATUS □□□■	End of CNC local RAM test
5	STATUS ■■■□	End of CNC local RAM clear
6	STATUS □■■□	FROM test in progress
7	STATUS ■□■□	End of key initialization. Logical slot setting is completed.
8	STATUS □□■□	End of CRT initialization. The CRT is ready for use.
9	STATUS ■■□■	Waiting for the completion of setting of the PC boards connected to the FANUC bus (1)
10	STATUS □■□■	IPL monitoring in progress
11	STATUS ■■□□	End of IPL
12	STATUS ■□■■	Waiting for the setting of *SYSFAIL
13	STATUS □□■■	Waiting for the completion of setting of the PC boards connected to the FANUC bus (2)
14	STATUS □■□□	Waiting for the completion of initialization of the servo
15	STATUS ■□□□	Normal state. The power-on sequence is ended.

2. LED display when an error occurs (STATUS LED)

No.	LED display	NC status
1	STATUS ★□□□	An error (1) occurred in the DRAM module of the CNC.
2	STATUS □★□□	An error occurred in the file SRAM.
3	STATUS ★★□□	An error (2) occurred in the DRAM module of the CNC.
4	STATUS □□★□	The CRT control module is not supported by the installed CNC software.
5	STATUS ★□★□	The main CPU board is not supported by the installed CNC software.
6	STATUS □★★□	An illegal PC board is installed in a slot of the FA-NUC bus. Two or more identical PC boards are installed when only one is permitted.
7	STATUS ★★★□	A system error (stack overflow) occurred.
8	STATUS □□□★	An illegal module is installed in the flash ROM module.
9	STATUS ★□□★	A flash ROM file configuration error (CNC area) occurred.
10	STATUS □★□★	A flash ROM file configuration error (PMC area) occurred.
16	STATUS □■ ■■	A system error (NMI to the CNC CPU) occurred.

3. LED display (STATUS LED) when an error occurs

No.	LED display	NC status
1	ALARM ■□□	Battery voltage for backup decreases.
2	ALARM □■□	SYSFAIL (A fault occurred on some modules of F-BUS)
3	ALARM ■■□	SERVO ALARM
4	ALARM □□■	SYSEMG (NMI occurred on some modules of F-BUS.)
5	ALARM ■□■	ABC ALARM (Parity alarm on FILE SRAM, A fault of peripheral bus)
6	ALARM □■■	Parity alarm occurred on DRAM area

2.5.3

(1) Parts layout

Configuration of the Main CPU Board (MAIN-A)

Drawing number : A16B-2201-0300

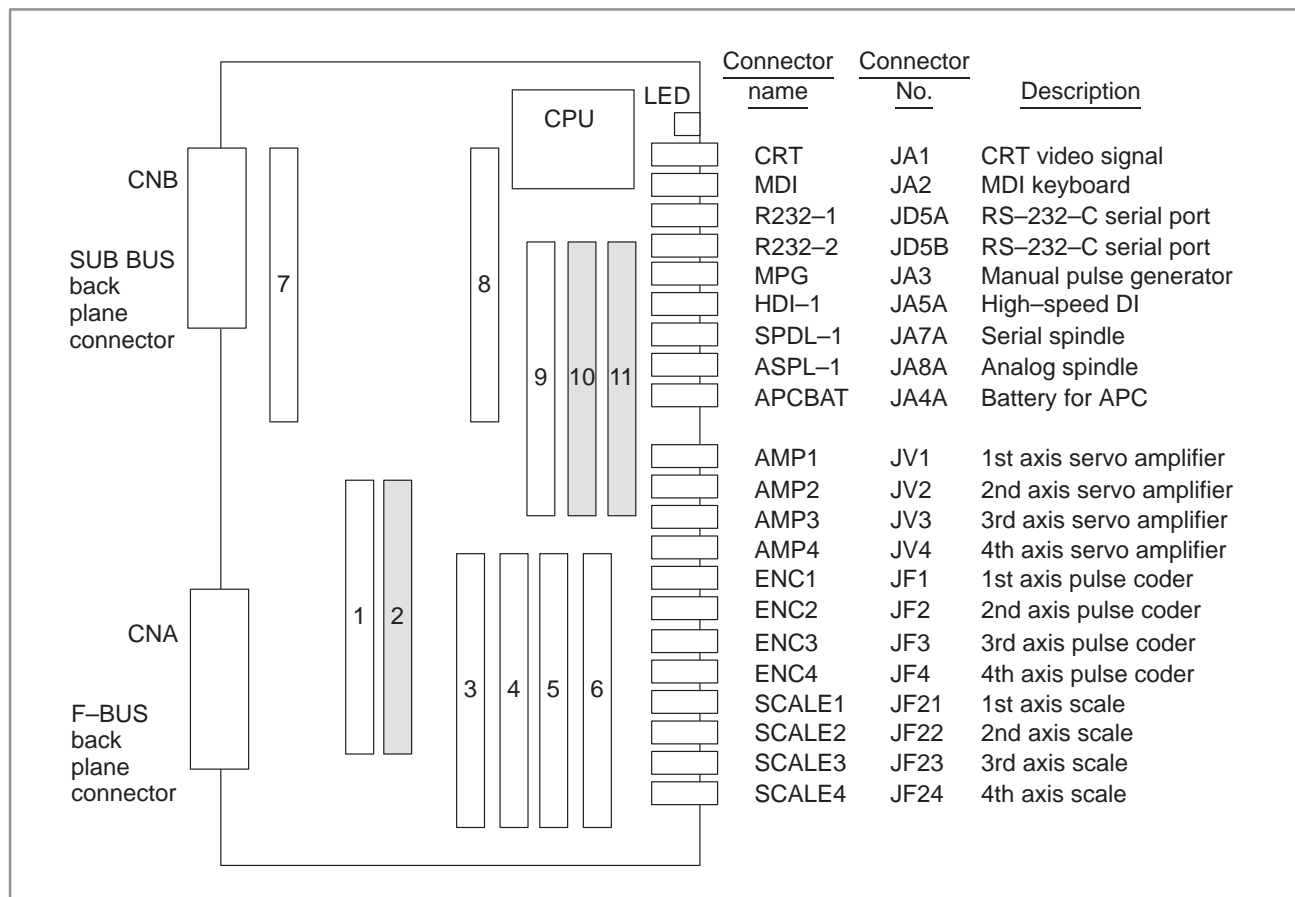

No.	Module name	Function outline
1	CRT control module	CRT display control
2	SRAM module	Part program storage, RAM for parameter
3	Servo control module	3rd and 4th servo control
4	Servo control module	1st and 2nd servo control
5	Servo interface module	3rd and 4th amplifier, pulse coder interface
6	Servo interface module	1st and 2nd amplifier, pulse coder interface
7	High-speed SRAM module	High-speed RAM for CNC system
8	DRAM module	RAM for CNC system
9	FLASH ROM module	FLASH-EPROM for CNC system
10	Spindle control module	System clear, battery backup control, spindle control, HDI interface etc....
11	Peripheral module	MDI, MPG, RS-232C, etc.... interface System timer, system clock, calendar clock

WARNING
 [] means the module connected power supply for battery backup. If the module are taken away carelessly, the backup are lost.

NOTE
 If a peripheral module is replaced, the time indicator may be disabled. In such a case, turn off the CNC. Then, turn on the CNC while holding down both the [-] key and [2] key on the MDI keyboard. Keep the two keys held down until the position screen is displayed. Then, the time indicator will resume normal operation.

(2) Block diagram

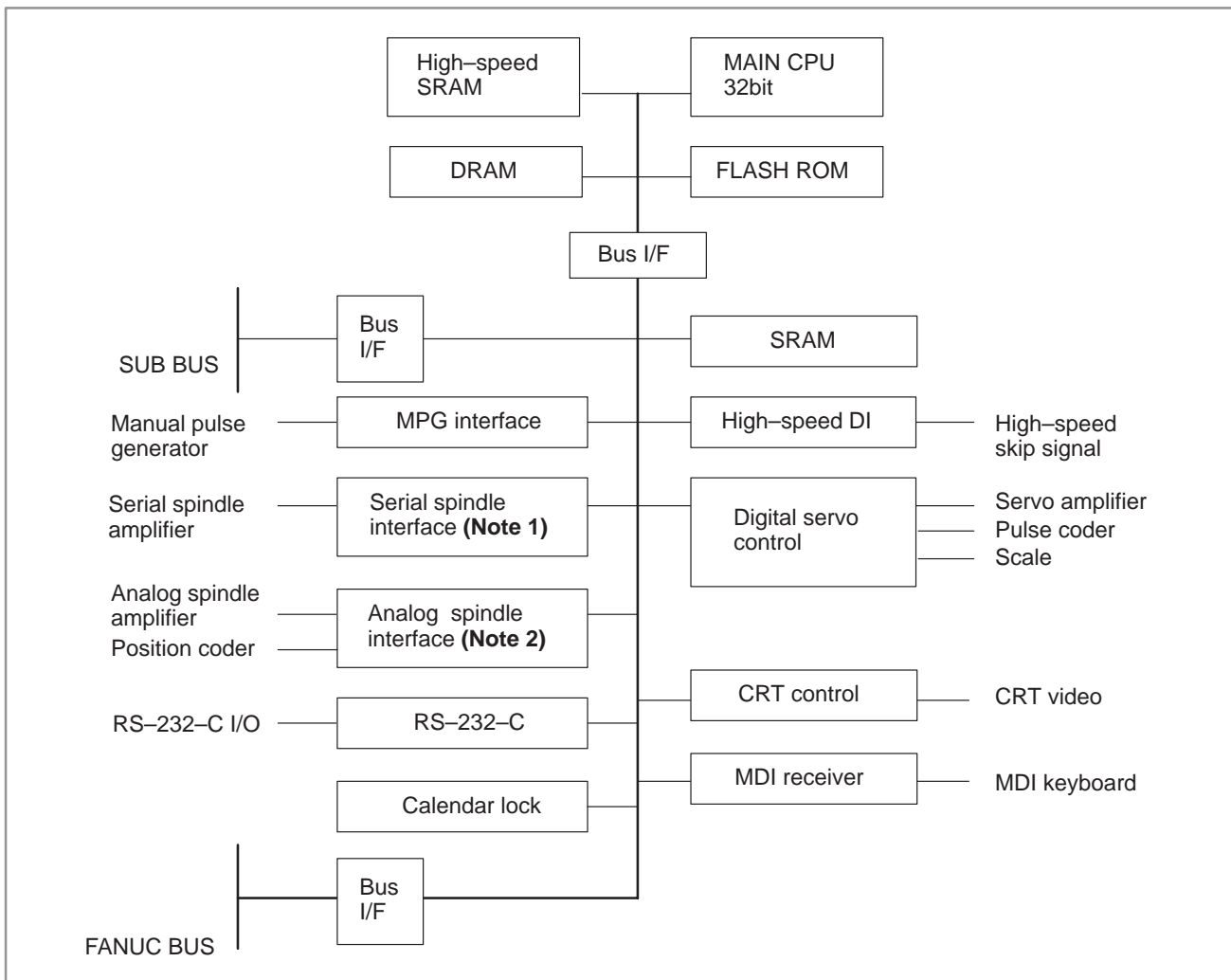

NOTE
 1 When the module of analog spindle is built in as module of spindle control, the serial spindle interface is not there.
 2 When a serial spindle module is mounted as the spindle control module, an analog spindle interface is not used.

(3) Adjustment

No adjustment is needed.

(4) LED display

□ : Not lit ■ : Lit ★ : Blinking

STATUS LEDs are green. ALARM LEDs are red.

1. LED display transition when the power is turned on
(STATUS LED)

No.	LED display	NC status
1	STATUS □□□□	Power-off
2	STATUS ■■■■	Initial state immediately after power-on
3	STATUS ■□□■	Beginning of activation of the CNC software
4	STATUS □□□■	End of CNC local RAM test
5	STATUS ■■■□	End of CNC local RAM clear
6	STATUS □■■□	FROM test in progress
7	STATUS ■□■□	End of key initialization. Logical slot setting is completed.
8	STATUS □□■□	End of CRT initialization. The CRT is ready for use.
9	STATUS ■■□■	Waiting for the completion of setting of the PC boards connected to the FANUC bus (1)
10	STATUS □■□■	IPL monitoring in progress
11	STATUS ■■□□	End of IPL
12	STATUS ■□■■	Waiting for the setting of *SYSFAIL
13	STATUS □□■■	Waiting for the completion of setting of the PC boards connected to the FANUC bus (2)
14	STATUS □■□□	Waiting for the completion of initialization of the servo
15	STATUS ■□□□	Normal state. The power-on sequence is ended.

2. LED display when an error occurs (STATUS LED)

No.	LED display	NC status
1	STATUS ★□□□	An error (1) occurred in the high-speed SRAM or DRAM module of the CNC.
2	STATUS □★□□	An error occurred in the file SRAM.
3	STATUS ★★□□	An error (2) occurred in the high-speed SRAM or DRAM module of the CNC.
4	STATUS □□★□	The CRT control module is not supported by the installed CNC software.
5	STATUS ★□★□	The main CPU board is not supported by the installed CNC software.
6	STATUS □★★□	An illegal PC board is installed in a slot of the FANUC bus. Two or more identical PC boards are installed when only one is permitted.
7	STATUS ★★★□	A system error (stack overflow) occurred.
8	STATUS □□□★	An illegal module is installed in the flash ROM module.
9	STATUS ★□□★	A flash ROM file configuration error (CNC area) occurred.
10	STATUS □★□★	A flash ROM file configuration error (PMC area) occurred.
16	STATUS □■ ■ ■	A system error (NMI to the CNC CPU) occurred.

3. LED display when an error occurs (ALARM LED)

No.	LED display	NC status
1	ALARM ■□□	The voltage of the backup battery has fallen below the specified minimum level.
2	ALARM □■□	SYSFAIL (fault in a module on the F-bus) occurred.
3	ALARM ■■□	A servo alarm occurred.
4	ALARM □□■	SYSEMG (NMI in a module on the F-bus) occurred.
5	ALARM ■□■	An ABC alarm (parity alarm in the file SRAM, fault in the peripheral bus, SUB bus, or FANUC bus) occurred.
6	ALARM □■■	A parity alarm occurred in the DRAM module.
7	ALARM ■■■	A parity alarm occurred in the high-speed SRAM module.

2.5.4 Configuration of the Upgraded Main CPU Board (MAIN-C)

(1) Parts layout

Drawing number : A16B-3200-0060

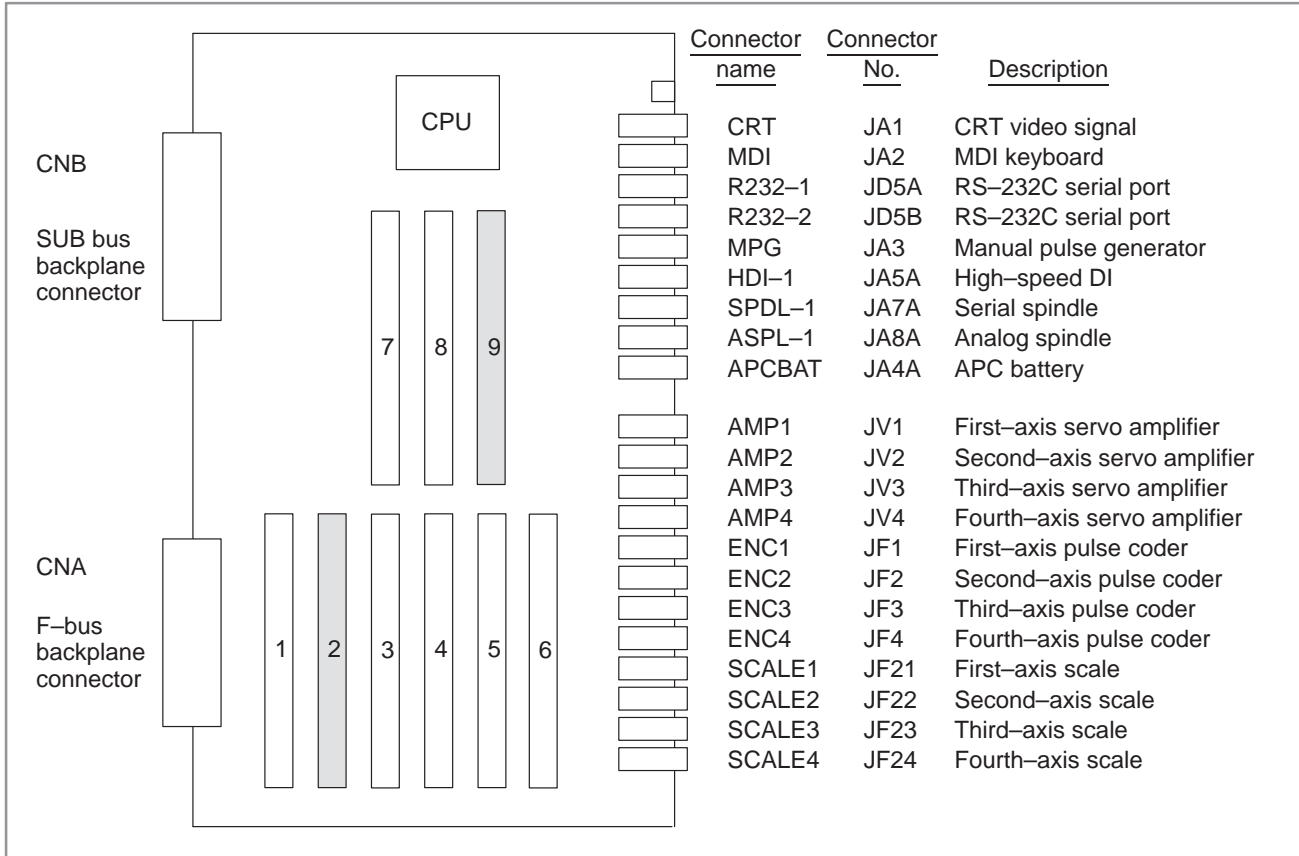

No.	Module name	Function outline
1	CRT control module	CRT display control
2	SRAM module	Part program storage, RAM for parameters
3	Servo control module	Third-axis and fourth-axis servo control
4	Servo control module	First-axis and second-axis servo control
5	Servo interface module	Third-axis and fourth-axis amplifier, pulse coder interface
6	Servo interface module	First-axis and second-axis amplifier, pulse coder interface
7	DRAM module	RAM for CNC system
8	Flash ROM module	Flash EPROM for CNC system
9	Spindle control module	System clear, battery backup, spindle control, HDI interface, etc.

WARNING
 Power for the battery backup is supplied to the module in the shaded box. If the module is disconnected, all data will be lost.

(2) Block diagram

See Subsec.2.5.2

(3) Adjustment

No adjustment is needed.

(4) LED display

□ : Not lit ■ : Lit ★ : Blinking

STATUS LEDs are green. ALARM LEDs are red.

1. LED display transition when the power is turned on
(STATUS LED)

No.	LED display	NC status
1	STATUS □□□□	Power-off
2	STATUS ■■■■	Initial state immediately after power-on
3	STATUS ■□□■	Beginning of activation of the CNC software
4	STATUS □□□■	End of CNC local RAM test
5	STATUS ■■■□	End of CNC local RAM clear
6	STATUS □■■□	FROM test in progress
7	STATUS ■□■□	End of key initialization. Logical slot setting is completed.
8	STATUS □□■□	End of CRT initialization. The CRT is ready for use.
9	STATUS ■■□■	Waiting for the completion of setting of the PC boards connected to the FANUC bus (1)
10	STATUS □■□■	IPL monitoring in progress
11	STATUS ■■□□	End of IPL
12	STATUS ■□■■	Waiting for the setting of *SYSFAIL
13	STATUS □□■■	Waiting for the completion of setting of the PC boards connected to the FANUC bus (2)
14	STATUS □■□□	Waiting for the completion of initialization of the servo
15	STATUS ■□□□	Normal state. The power-on sequence is ended.

2. LED display when an error occurs (STATUS LED)

No.	LED display	NC status
1	STATUS ★□□□	An error (1) occurred in the DRAM module of the CNC.
2	STATUS □★□□	An error occurred in the file SRAM.
3	STATUS ★★□□	An error (2) occurred in the DRAM module of the CNC.
4	STATUS □□★□	The CRT control module is not supported by the installed CNC software.
5	STATUS ★□★□	The main CPU board is not supported by the installed CNC software.
6	STATUS □★★□	An illegal PC board is installed in a slot of the FANUC bus. Two or more identical PC boards are installed when only one is permitted.
7	STATUS ★★★□	A system error (stack overflow) occurred.
8	STATUS □□□★	An illegal module is installed in the flash ROM module.
9	STATUS ★□□★	A flash ROM file configuration error (CNC area) occurred.
10	STATUS □★□★	A flash ROM file configuration error (PMC area) occurred.
16	STATUS □■ ■■	A system error (NMI to the CNC CPU) occurred.

3. LED display when an error occurs (ALARM LED)

No.	LED display	NC status
1	ALARM ■□□	The voltage of the backup battery has fallen below the specified minimum level.
2	ALARM □■□	SYSFAIL (fault in a module on the F-bus) occurred.
3	ALARM ■■□	A servo alarm occurred.
4	ALARM □□■	SYSEMG (NMI in a module on the F-bus) occurred.
5	ALARM ■□■	An ABC alarm (parity alarm in the file SRAM, fault in the peripheral bus or FANUC bus) occurred.
6	ALARM □■■	A parity alarm occurred in the DRAM module.
7	ALARM ■■■	A parity alarm occurred in the shared RAM on the SUB board.

2.5.5 Configuration of the High-speed Multiaxis Main CPU Board (MAX MAIN-A)

(1) Parts layout

Drawing number : A16B-2201-0340

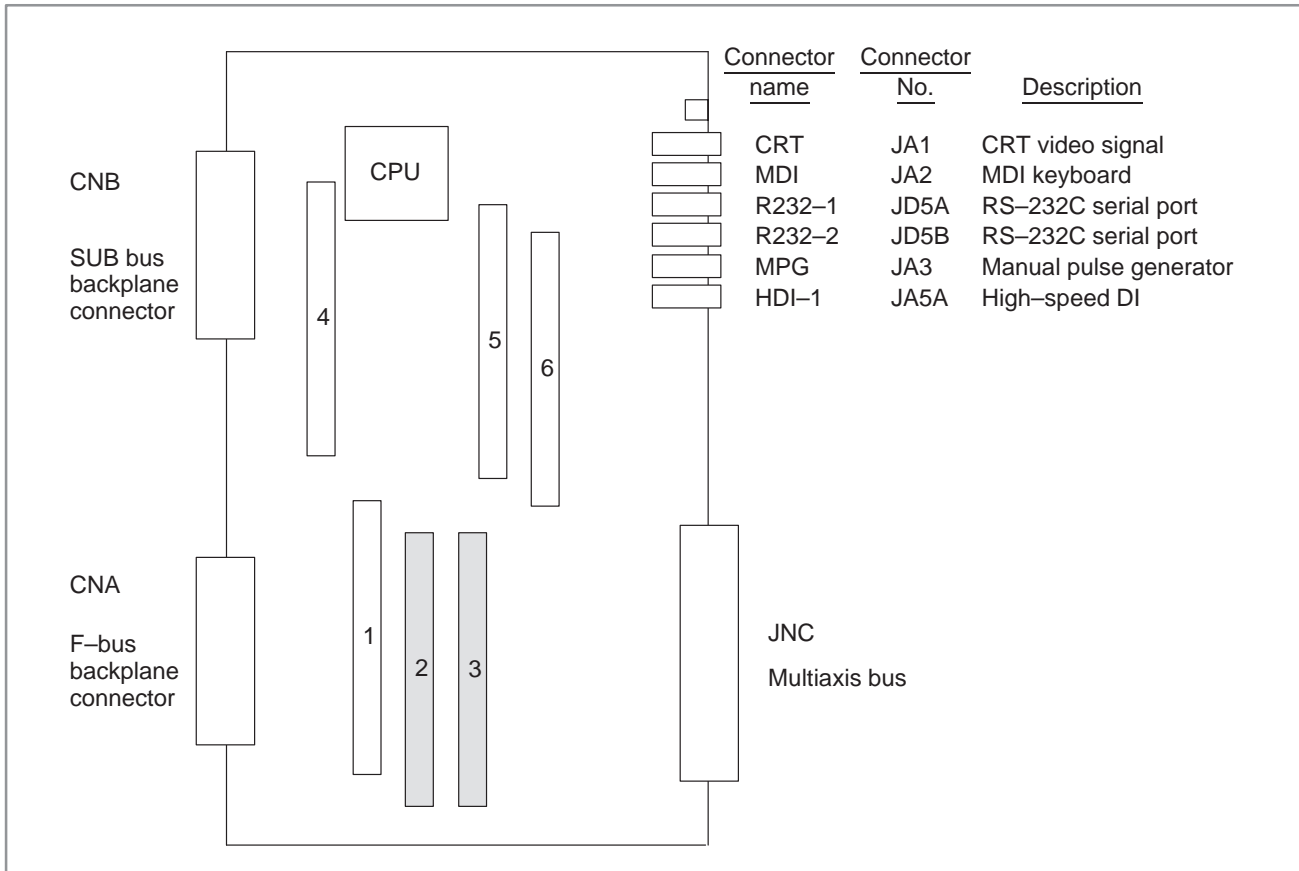

No.	Module name	Function outline
1	CRT control module	CRT display control
2	SRAM module	Part program storage, RAM for parameters
3	Peripheral module	Interface such as MDI, MPG, and RS-232C, system timer, system clock, calendar clock
4	High-speed SRAM module	High-speed RAM for CNC system
5	DRAM module	RAM for CNC system
6	FLASH ROM module	FLASH EPROM for CNC system

WARNING
 Power for the battery backup is supplied to the module in the shaded box. If the module is disconnected, all data will be lost.

NOTE

If a peripheral module is replaced, the time indicator may be disabled. In such a case, turn off the CNC. Then, turn on the CNC while holding down both the key and key on the MDI keyboard. Keep the two keys held down until the position screen is displayed. Then, the time indicator will resume normal operation.

(2) Block diagram

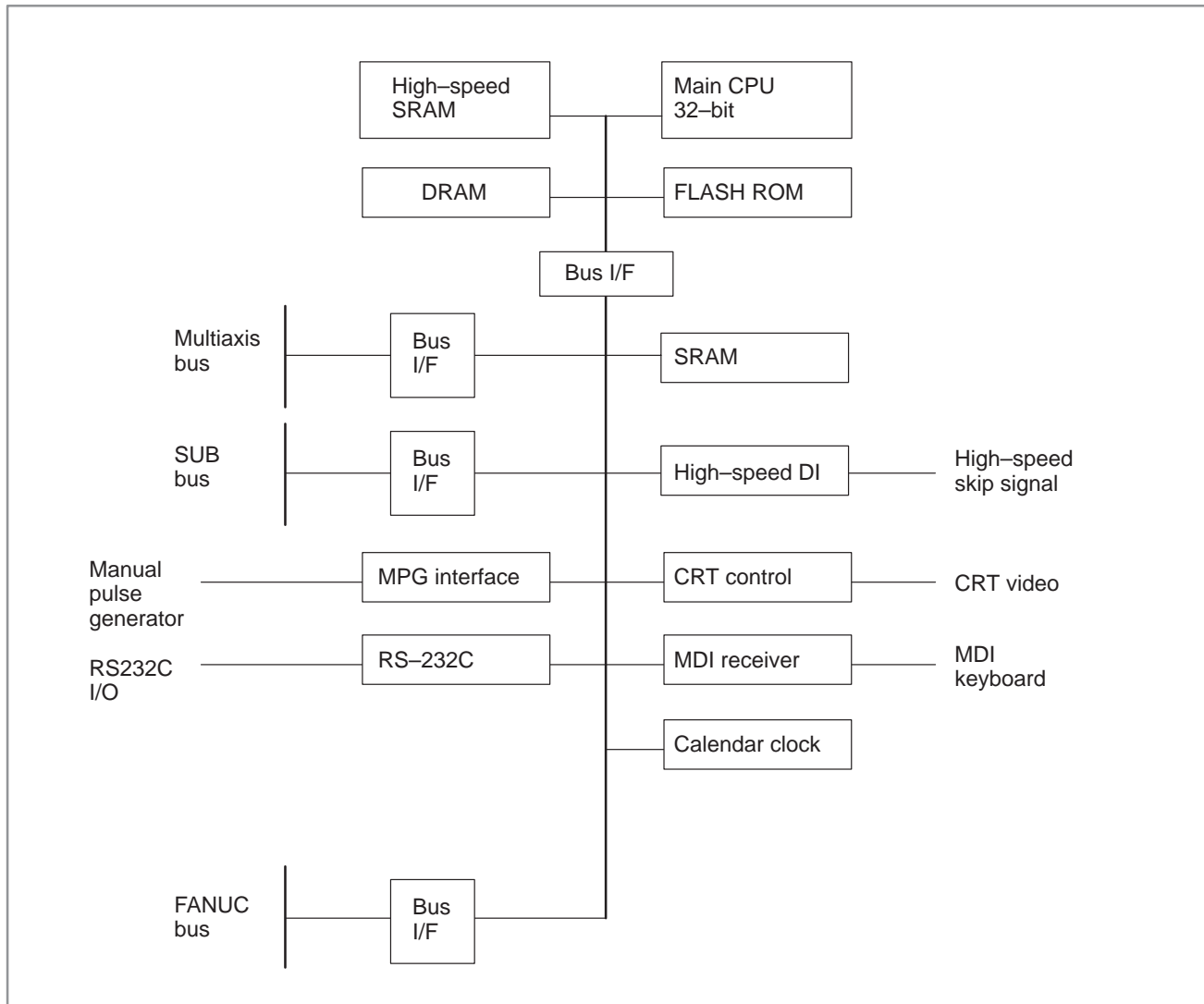

(3) Adjustment

No adjustment is needed.

(4) LED display

□ : Not lit ■ : Lit ★ : Blinking

STATUS LEDs are green. ALARM LEDs are red.

1. LED display transition when the power is turned on
(STATUS LED)

No.	LED display	NC status
1	STATUS □□□□	Power-off
2	STATUS ■■■■	Initial state immediately after power-on
3	STATUS ■□□■	Beginning of activation of the CNC software
4	STATUS □□□■	End of CNC local RAM test
5	STATUS ■■■□	End of CNC local RAM clear
6	STATUS □■■□	FROM test in progress
7	STATUS ■□■□	End of key initialization. Logical slot setting is completed.
8	STATUS □□■□	End of CRT initialization. The CRT is ready for use.
9	STATUS ■■□■	Waiting for the completion of setting of the PC boards connected to the FANUC bus (1)
10	STATUS □■□■	IPL monitoring in progress
11	STATUS ■■□□	End of IPL
12	STATUS ■□■■	Waiting for the setting of *SYSFAIL
13	STATUS □□■■	Waiting for the completion of setting of the PC boards connected to the FANUC bus (2)
14	STATUS □■□□	Waiting for the completion of initialization of the servo
15	STATUS ■□□□	Normal state. The power-on sequence is ended.

2. LED display when an error occurs (STATUS LED)

No.	LED display	NC status
1	STATUS ★□□□	An error (1) occurred in the high-speed SRAM or DRAM module of the CNC.
2	STATUS □★□□	An error occurred in the file SRAM.
3	STATUS ★★□□	An error (2) occurred in the high-speed SRAM or DRAM module of the CNC.
4	STATUS □□★□	The CRT control module is not supported by the installed CNC software.
5	STATUS ★□★□	The main CPU board is not supported by the installed CNC software.
6	STATUS □★★□	An illegal PC board is installed in a slot of the FANUC bus. Two or more identical PC boards are installed when only one is permitted.
7	STATUS ★★★□	A system error (stack overflow) occurred.
8	STATUS □□□★	An illegal module is installed in the flash ROM module.
9	STATUS ★□□★	A flash ROM file configuration error (CNC area) occurred.
10	STATUS □★□★	A flash ROM file configuration error (PMC area) occurred.
16	STATUS □■ ■■	A system error (NMI to the CNC CPU) occurred.

3. LED display when an error occurs (ALARM LED)

No.	LED display	NC status
1	ALARM ■□□	The voltage of the backup battery has fallen below the specified minimum level.
2	ALARM □■□	SYSFAIL (fault in a module on the F-bus) occurred.
3	ALARM ■■□	SYSEMG occurred in an additional shelf. (An NMI occurred in a module mounted on the F-bus of the additional shelf side.)
4	ALARM □□■	SYSEMG (NMI in a module on the F-bus) occurred.
5	ALARM ■□■	An ABC alarm (parity alarm in the file SRAM, fault in the peripheral bus, SUB bus, multiaxis bus, or FANUC bus) occurred.
6	ALARM □■■■	A parity alarm occurred in the DRAM module.
7	ALARM ■■■■	A parity alarm occurred in the high-speed SRAM module.

2.5.6 Configuration of the Level Up Multiaxis Main CPU Board (MAX MAIN-C)

(1) Parts layout

Drawing number : A16B-2202-0640

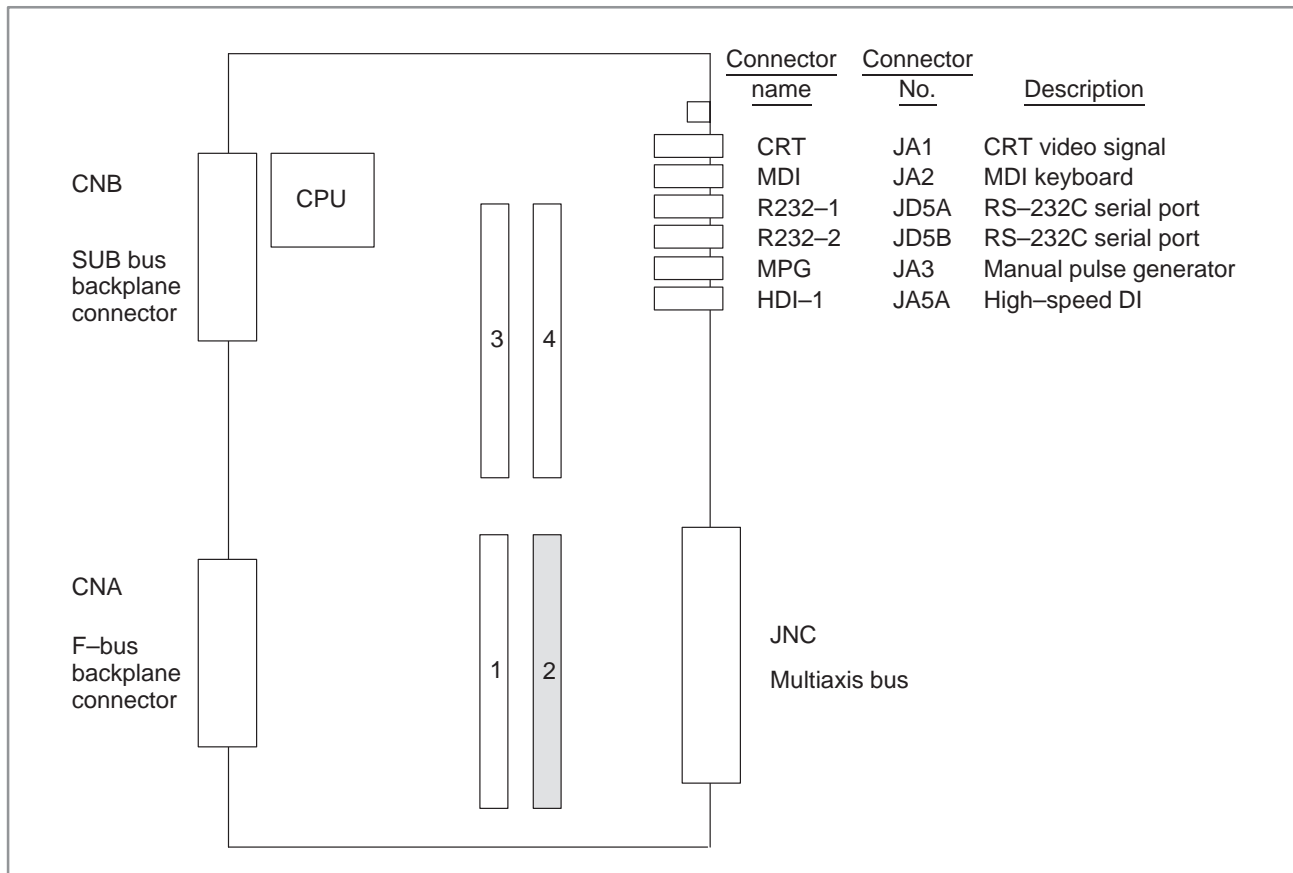

No.	Module name	Function outline
1	CRT control module	CRT display control
2	SRAM module	Part program storage, RAM for parameters
3	DRAM module	RAM for CNC system
4	FLASH ROM module	FLASH EPROM for CNC system

WARNING

Power for the battery backup is supplied to the module in the shaded box. If the module is disconnected, all data will be lost.

(4) LED display

□ : Not lit ■ : Lit ★ : Blinking

STATUS LEDs are green. ALARM LEDs are red.

1. LED display transition when the power is turned on
(STATUS LED)

No.	LED display	NC status
1	STATUS □□□□	Power-off
2	STATUS ■■■■	Initial state immediately after power-on
3	STATUS ■□□■	Beginning of activation of the CNC software
4	STATUS □□□■	End of CNC local RAM test
5	STATUS ■■■□	End of CNC local RAM clear
6	STATUS □■■□	FROM test in progress
7	STATUS ■□■□	End of key initialization. Logical slot setting is completed.
8	STATUS □□■□	End of CRT initialization. The CRT is ready for use.
9	STATUS ■■□■	Waiting for the completion of setting of the PC boards connected to the FANUC bus (1)
10	STATUS □■□■	IPL monitoring in progress
11	STATUS ■■□□	End of IPL
12	STATUS ■□■■	Waiting for the setting of *SYSFAIL
13	STATUS □□■■	Waiting for the completion of setting of the PC boards connected to the FANUC bus (2)
14	STATUS □■□□	Waiting for the completion of initialization of the servo
15	STATUS ■□□□	Normal state. The power-on sequence is ended.

2. LED display when an error occurs (STATUS LED)

No.	LED display	NC status
1	STATUS ★□□□	An error (1) occurred in the high-speed SRAM or DRAM module of the CNC.
2	STATUS □★□□	An error occurred in the file SRAM.
3	STATUS ★★□□	An error (2) occurred in the high-speed SRAM or DRAM module of the CNC.
4	STATUS □□★□	The CRT control module is not supported by the installed CNC software.
5	STATUS ★□★□	The main CPU board is not supported by the installed CNC software.
6	STATUS □★★□	An illegal PC board is installed in a slot of the FANUC bus. Two or more identical PC boards are installed when only one is permitted.
7	STATUS ★★★□	A system error (stack overflow) occurred.
8	STATUS □□□★	An illegal module is installed in the flash ROM module.
9	STATUS ★□□★	A flash ROM file configuration error (CNC area) occurred.
10	STATUS □★□★	A flash ROM file configuration error (PMC area) occurred.
16	STATUS □■ ■■	A system error (NMI to the CNC CPU) occurred.

3. LED display when an error occurs (ALARM LED)

No.	LED display	NC status
1	ALARM ■□□	The voltage of the backup battery has fallen below the specified minimum level.
2	ALARM □■□	SYSFAIL (fault in a module on the F-bus) occurred.
3	ALARM ■■□	SYSEMG occurred in an additional shelf. (An NMI occurred in a module mounted on the F-bus of the additional shelf side.)
4	ALARM □□■	SYSEMG (NMI in a module on the F-bus) occurred.
5	ALARM ■□■	An ABC alarm (parity alarm in the file SRAM, fault in the peripheral bus, SUB bus, multiaxis bus, or FANUC bus) occurred.
6	ALARM □■■	A parity alarm occurred in the DRAM module.
7	ALARM ■■■	A parity alarm occurred in the high-speed SRAM module.

(2) Block diagram

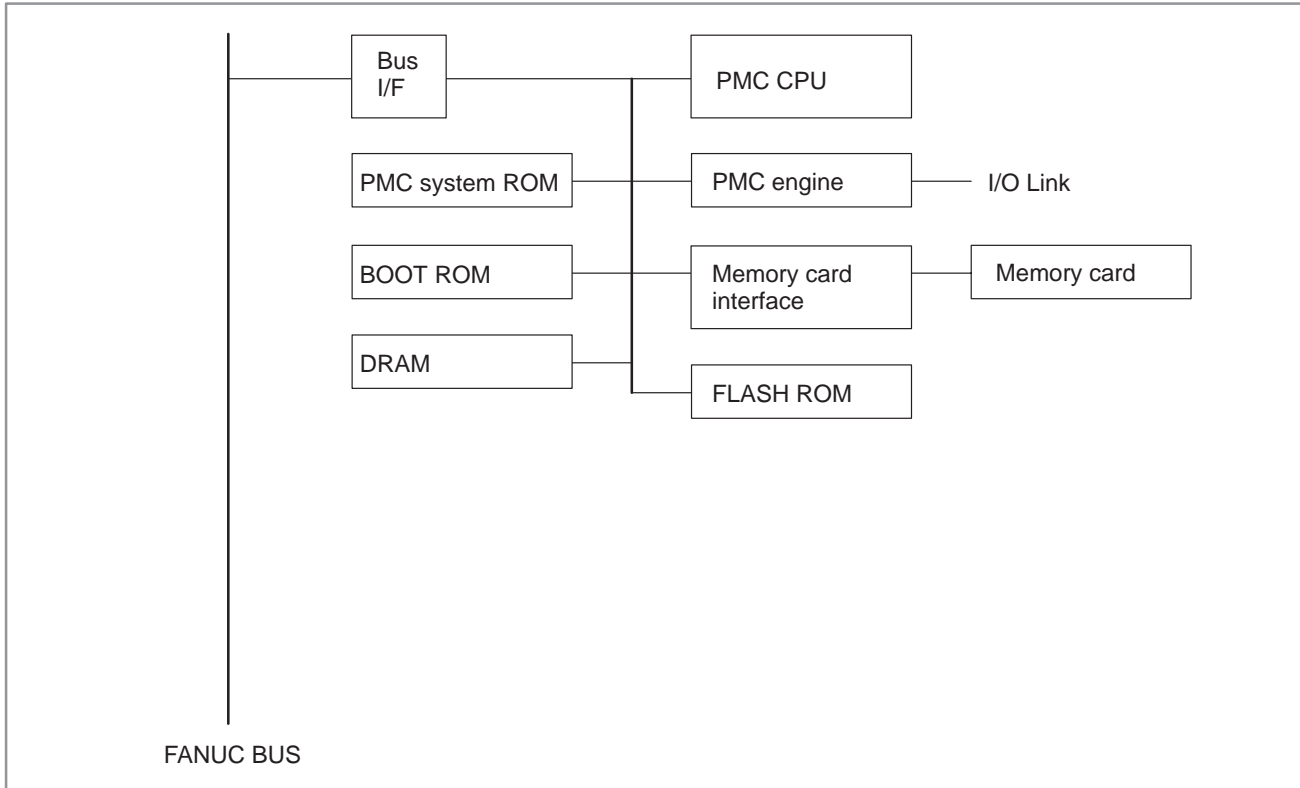

(3) Adjustment

No adjustment is needed.

(4) LED display

Of the STATUS LEDs provided at the top on the front edge of the PMC-NA board, only two are valid as shown on the right:

Legend

□ : Not lit ■ : Lit ★☆ : Blinking ◆ : Irrelevant

★★ represents that the two LEDs blink simultaneously.

★☆ represents that the two LEDs blink alternately.

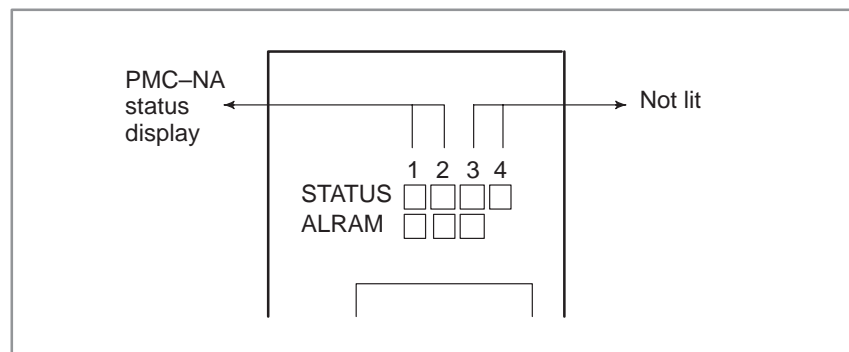

(a) STATUS LED display for the PMC-NA function

1. STATUS LED display transition when the power is turned on

No.	LED display	NC status
1	STATUS □□□□	Power-off
2	STATUS ■■□□	Initial state immediately after power-on or the state in which the PMC CPU is not operating
3	STATUS □■□□	Initial state. PMC initialization is in progress.
4	STATUS ■□□□	Initial state PMC ROM parity check, transfer of a Ladder or PASCAL program to DRAM in progress, SLC initialization in progress (IPL is completed in the CNC and the NC ready status is awaited.)
5	STATUS □□□□	Normal state

2. STATUS LED display when an error occurs

No.	LED display	NC status
1	STATUS ★★□□	An error occurred in another PC board.
2	STATUS ■★□□	An error occurred during transfer from or to DI/DO. The DRAM module to be installed on the main CPU is defective.
3	STATUS ★■□□	A RAM parity error occurred in the PMC engine module (upon accessing the BOC).
4	STATUS □★□□	A RAM parity error occurred in the PMC engine module or PMC DRAM module (upon accessing the CPU).
5	STATUS ★◆□□	A failure (BUS ERR, ADDR ERR, ILL INST, ZERO DIV, etc.) occurred in the PMC function. The PMC ROM is defective.

(b) ALARM LED display

No.	LED display	NC status
1	ALARM □■□	The PMC CPU asserts SYSFAIL.
2	ALARM ■■□	The PMC CPU is in the stop state.
3	ALARM □□■	An error (SLC error) occurred during data transfer to or from DI/DO.
4	ALARM ■■■	A RAM (RAM on the PMC engine module or PMC DRAM module) parity error occurred in the PMC.

2.5.8 Configuration of the PMC-NA Board with or without the Conversational Function

(1) Parts layout

Drawing numbers : A16B-2201-0390 (PMC-NA board with conversational function)
 A16B-2201-0391 (PMC-NA board without conversational function)

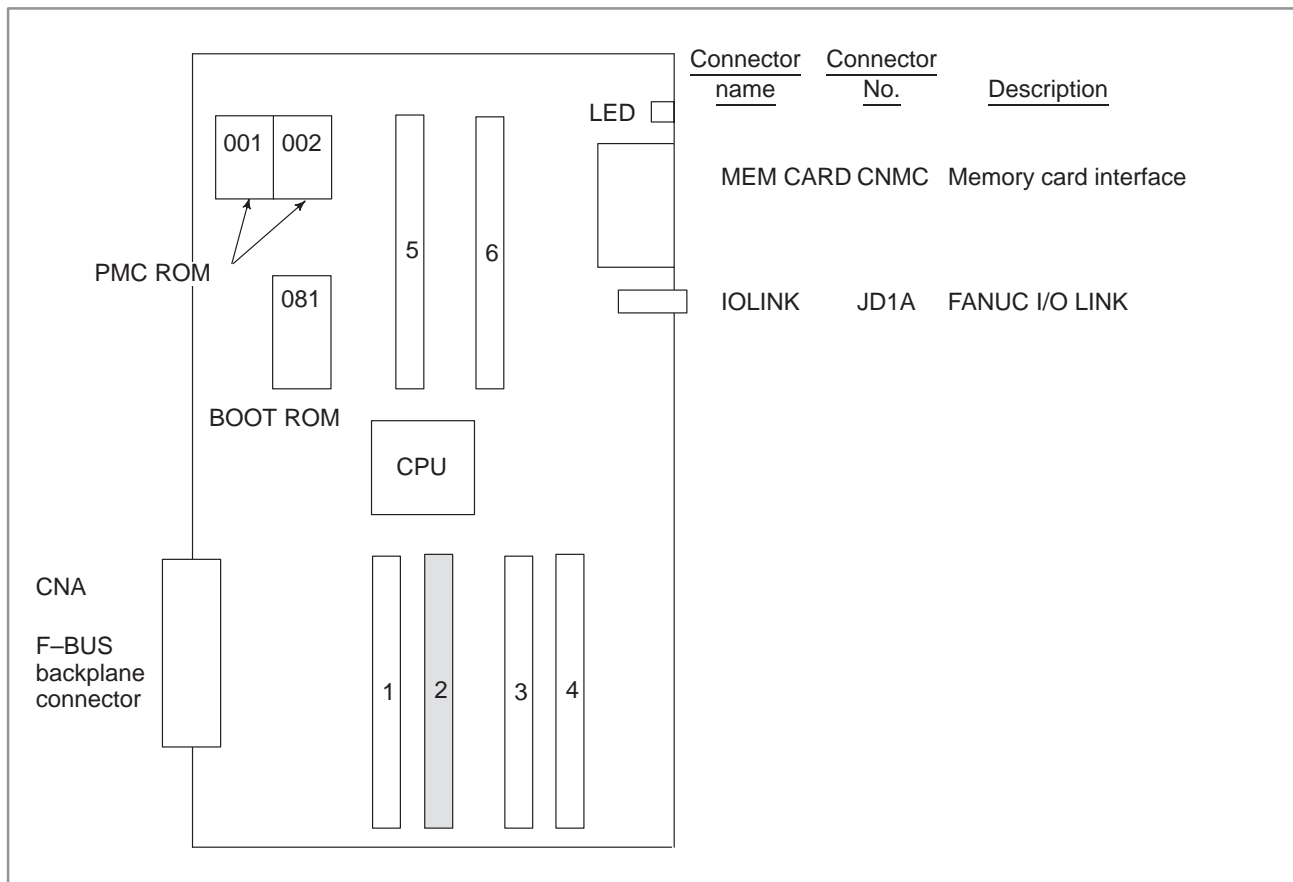

No.	Module name	Function outline
1	Conversational CPU module	CPU module for the conversational function
2	SRAM module	Sub-memory for the conversational function
3	DRAM module	Work DRAM for the conversational function
4	ROM module	System ROM for the conversational function
5	PMC engine module	PMC operation control, I/O Link control
6	DRAM module	Work RAM for PMC-NA

WARNING
 Power for the battery backup is supplied to the module in the shaded box. If the module is disconnected, all data will be lost.

(2) Block diagram

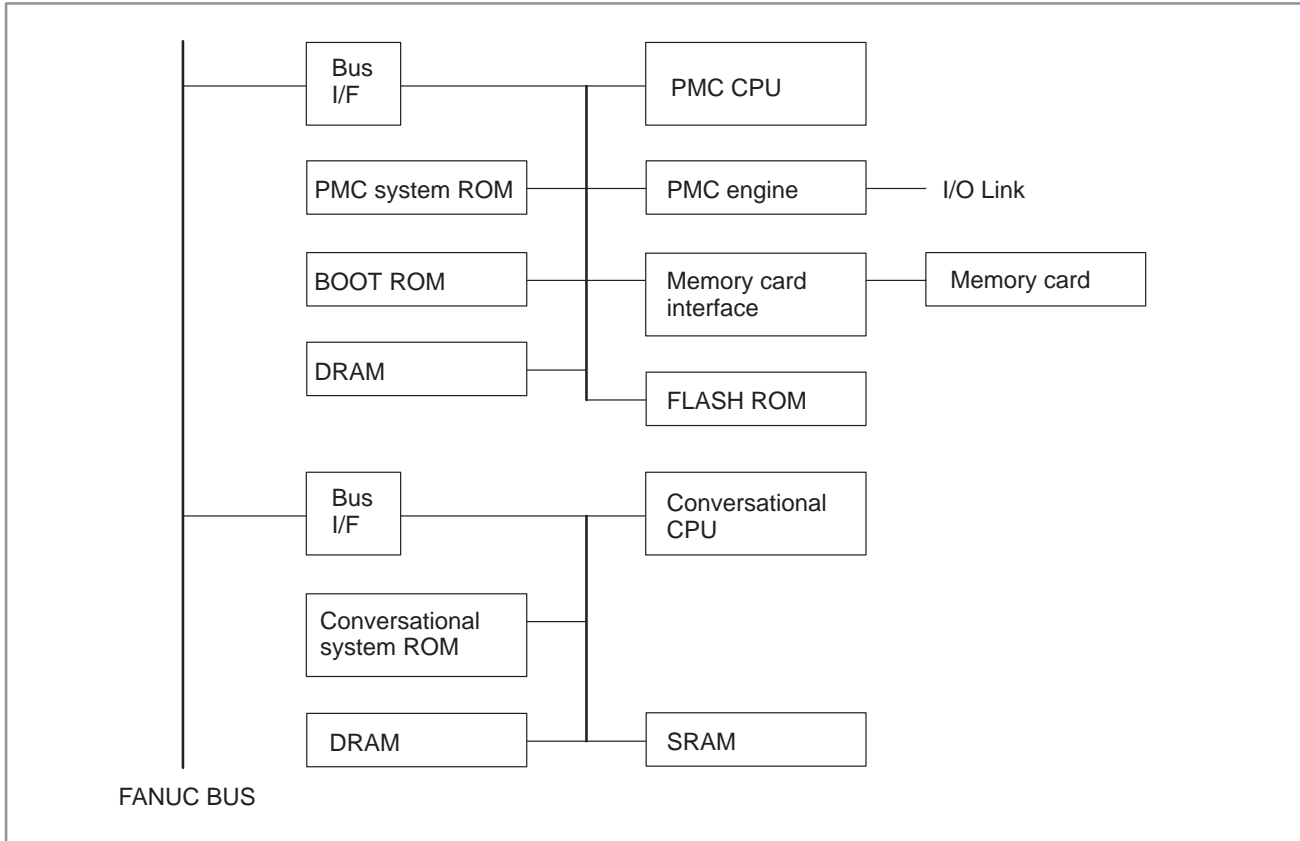

(3) Adjustment

No adjustment is needed.

(4) LED display

The STATUS LEDs at the top of the front of the PMC-NA board having the conversational function are used for independent functions, as shown on the right.

Legend

- : Not lit ■ : Lit ★★ : Blinking ◆ : Irrelevant
- ★★ represents that the two LEDs blink simultaneously.
- ★☆☆ represents that the two LEDs blink alternately.

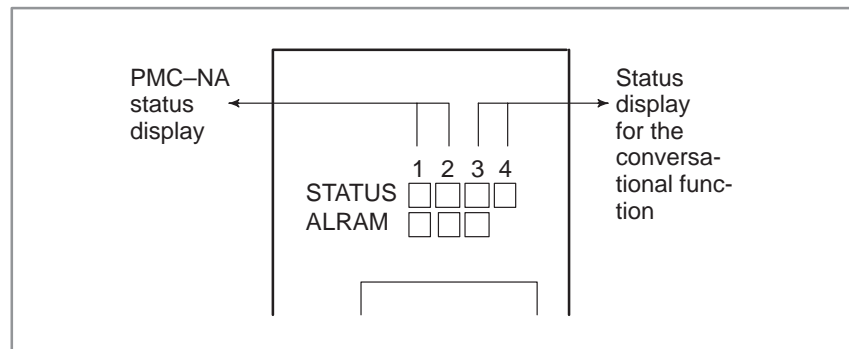

(a) LED display for the PMC-NA function

1. STATUS LED display transition when the power is turned on

No.	LED display	NC status
1	STATUS □□□□	Power-off
2	STATUS ■■◆◆	Initial state immediately after power-on or the state in which the PMC CPU is not operating
3	STATUS □■◆◆	Initial state. PMC initialization is in progress.
4	STATUS ■□◆◆	Initial state PMC ROM parity check, transfer of a Ladder or PASCAL program to DRAM in progress, SLC initialization in progress (IPL is completed in the CNC and the NC ready status is awaited.)
5	STATUS □□◆◆	Normal state

2. STATUS LED display for the PMC-NA function upon the occurrence of an error

No.	LED display	NC status
1	STATUS ★★◆◆	An error occurred in another PC board.
2	STATUS ■★◆◆	An error occurred during transfer to or from DI/DO. Alternatively, the DRAM module on the main CPU board is defective.
3	STATUS ★■◆◆	A RAM parity error occurred in the PMC engine module (upon accessing the BOC).
4	STATUS □★◆◆	A RAM parity error occurred in the PMC engine module or PMC DRAM module (upon accessing the CPU).
5	STATUS ★☆◆◆	A failure (BUS ERR, ADDR ERR, ILL INST, ZERO DIV, etc.) occurred in the PMC function. The PMC ROM is defective.

(b) STATUS LED display for the conversational function
(15-TFB, 15-TTFB, 15-MFB, 15TEF)

1. STATUS LED display transition when the power is turned on

No.	LED display	NC status
1	STATUS □□□□	Power-off
2	STATUS ◆◆□■	Waiting for initialization of the main CPU (waiting for ID setting)
3	STATUS ◆◆■□	Initialized state
4	STATUS ◆◆□□	Normal state

2. STATUS LED display for the conversational function upon the occurrence of an error (15-TFB, 15TTFB, 15TEF)

No.	LED display	NC status
1	STATUS ★★◆◆	An error occurred in another PC board.
2	STATUS ★★□◆	A RAM parity error occurred on the PC board for the conversational function.
3	STATUS ◆◆★☆	A defective ROM module was detected on the PC board for the conversational function.
4	STATUS ◆◆■□	The CPU for the conversational function performed illegal processing.

3. STATUS LED display for the conversational function when an error occurs (15-MFB)

No.	LED display	NC status
1	STATUS ◆◆★★	An error occurred in another PC board or the CPU for the conversational function.

(c) ALARM LED display

No.	LED display	NC status
1	ALARM ■□□	The CPU for the conversational function asserts SYSFAIL.
2	ALARM □■□	The PMC CPU asserts SYSFAIL.
3	ALARM ■■□	The PMC CPU is in the stop state.
4	ALARM □□■	An error (SLC error) occurred during data transfer to or from DI/DO.
5	ALARM ■■■	A RAM (RAM on the PMC engine module or PMC DRAM module) parity error occurred in the PMC.

2.5.9 Configuration of the PMC-NB Board with or without the Conversational Function

(1) Parts layout

Drawing numbers : A16B-2201-0810 (PMC-NB board with conversational function)
 A16B-2201-0811 (PMC-NB board without conversational function)
 A16B-2201-0381 (PMC-NB board without conversational function)

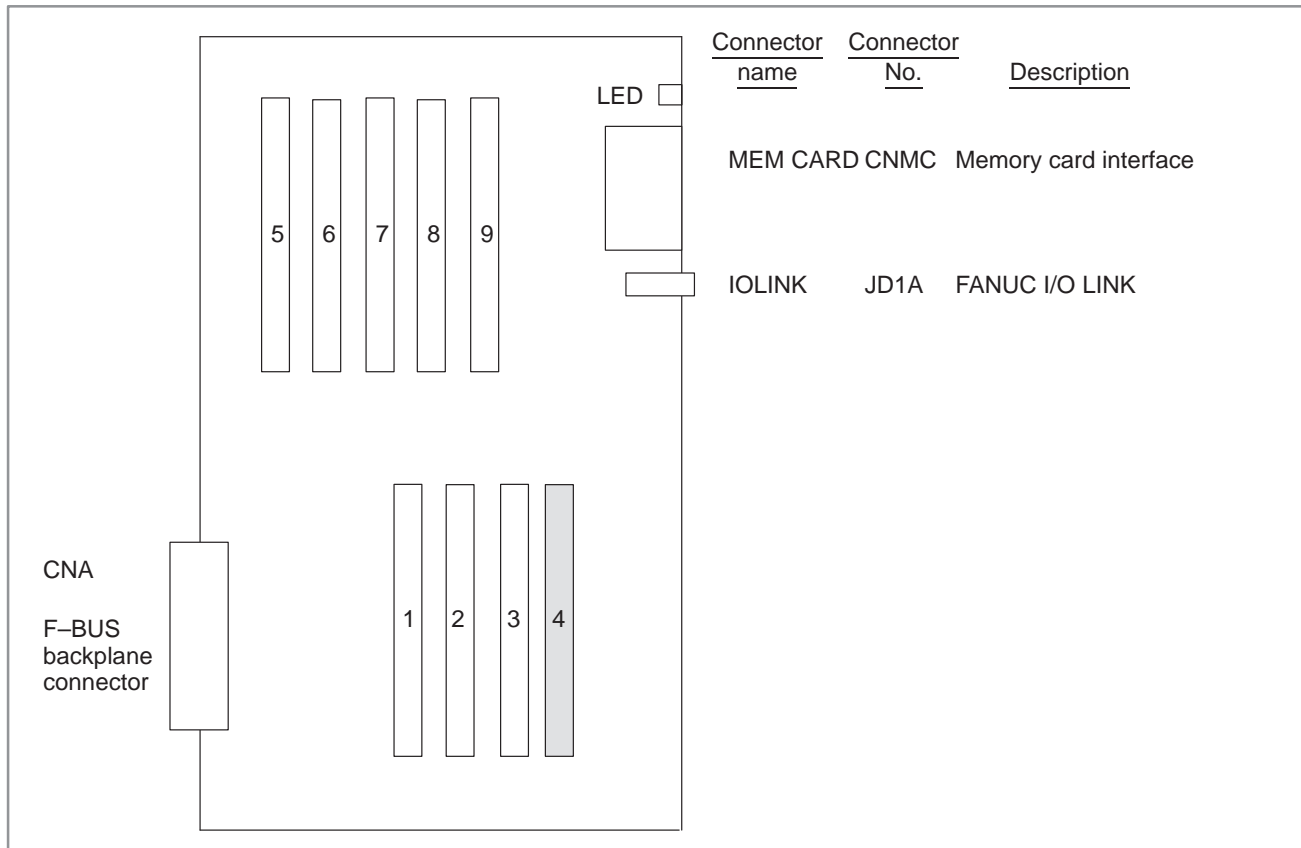

No.	Module name	Function outline
1	Conversational CPU module	CPU module for conversational function
2	DRAM module	Work RAM for conversational function
3	ROM module	System ROM for conversational function
4	SRAM module	Sub-memory for conversational function
5	ROM module	System ROM for PMC-NB
6	PMC CPU module	CPU module for PMC-NB
7	PMC engine module	PMC operation control, I/O Link control
8	SRAM module	Work RAM for PMC-NB
9	FLASH ROM module	FLASH EPROM

WARNING

Power for battery backup is supplied to the module in the shaded box. If the module is disconnected, all data will be lost.

(2) Block diagram

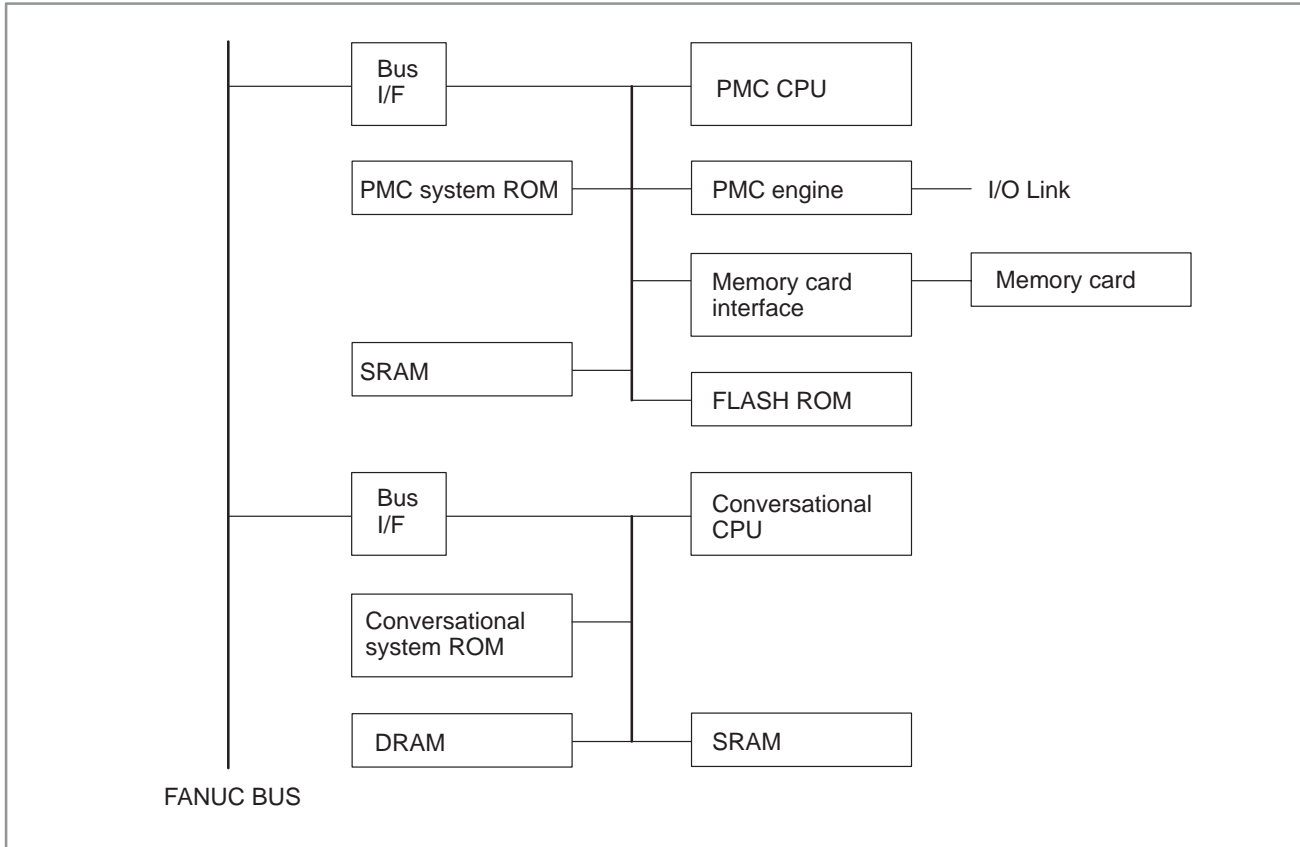

(3) Adjustment

No adjustment is needed.

(4) LED display

The STATUS LEDs at the top of the front of the PMC-NB board having the conversational function are used for independent functions, as shown on the right.

Legend

- : Not lit ■ : Lit ☆☆ : Blinking ◆ : Irrelevant
- ☆☆ represents that the two LEDs blink simultaneously.
- ★☆ represents that the two LEDs blink alternately.

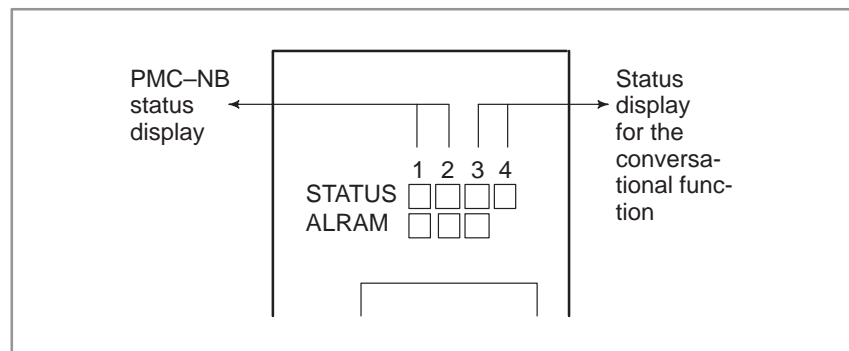

(a) LED display for the PMC–NB function

1. STATUS LED display transition when the power is turned on

No.	LED display	NC status
1	STATUS □□□□	Power-off
2	STATUS ■■◆◆	Initial state immediately after power-on or the state in which the PMC CPU is not operating
3	STATUS □■◆◆	Initial state. PMC initialization is in progress.
4	STATUS ■□◆◆	Initial state PMC ROM parity check, transfer of a Ladder or PASCAL program to DRAM in progress, SLC initialization in progress (IPL is completed in the CNC and the NC ready status is awaited.)
5	STATUS □□◆◆	Normal state

2. STATUS LED display for the PMC–NB function when an error occurs

No.	LED display	NC status
1	STATUS ★★◆◆	An error occurred in another PC board.
2	STATUS ■★◆◆	An error occurred during transfer to or from DI/DO. The DRAM module module on the main CPU board is defective. The PMC system ROM module is defective.
3	STATUS ★■◆◆	A RAM parity error occurred in the PMC engine module (during access to the PMC).
4	STATUS □★◆◆	A RAM parity error occurred in the PMC engine module or PMC SRAM module (during access to the CPU).
5	STATUS ★☆◆◆	A failure (BUS ERR, INVALID OPCODE, etc.) occurred in the PMC function. The PMC ROM is defective.

(b) STATUS LED display for the conversational function
(15-TFB, 15-TTFB, 15-MFB, 15TEF)

1. STATUS LED display transition when the power is turned on

No.	LED display	NC status
1	STATUS □□□□	Power-off
2	STATUS ◆◆□■	Waiting for initialization of the main CPU (waiting for ID setting)
3	STATUS ◆◆■□	Initialized state
4	STATUS ◆◆□□	Normal state

2. STATUS LED display for the conversational function when an error occurs (15-TBF, 15-TTFB, 15TEF)

No.	LED display	NC status
1	STATUS ◆◆★★	An error occurred in another PC board.
2	STATUS ◆◆□★	A RAM parity error occurred on the PC board for the conversational function.
3	STATUS ◆◆★★	A defective ROM module was detected on the PC board for the conversational function.
4	STATUS ◆◆■□	The CPU for the conversational function performed illegal processing.

3. STATUS LED display for the conversational function when an error occurs (15-MFB)

No.	LED display	NC status
1	STATUS ◆◆★★	An error occurred in another PC board or the CPU for the conversational function.

(c) ALARM LED display

No.	LED display	NC status
1	ALARM ■□□	The CPU for the conversational function asserts SYSFAIL.
2	ALARM □■□	The PMC CPU asserts SYSFAIL.
3	ALARM ■■□	The PMC CPU is in the stop state.
4	ALARM □□■	An error (SLC error) occurred during data transfer to or from DI/DO.
5	ALARM ■■■	A RAM (RAM on the PMC engine module or PMC SRAM module) parity error occurred in the PMC.

2.5.10 Configuration of the PMC-NB/NB2 Board with or without the Conversational Function

• Parts layout

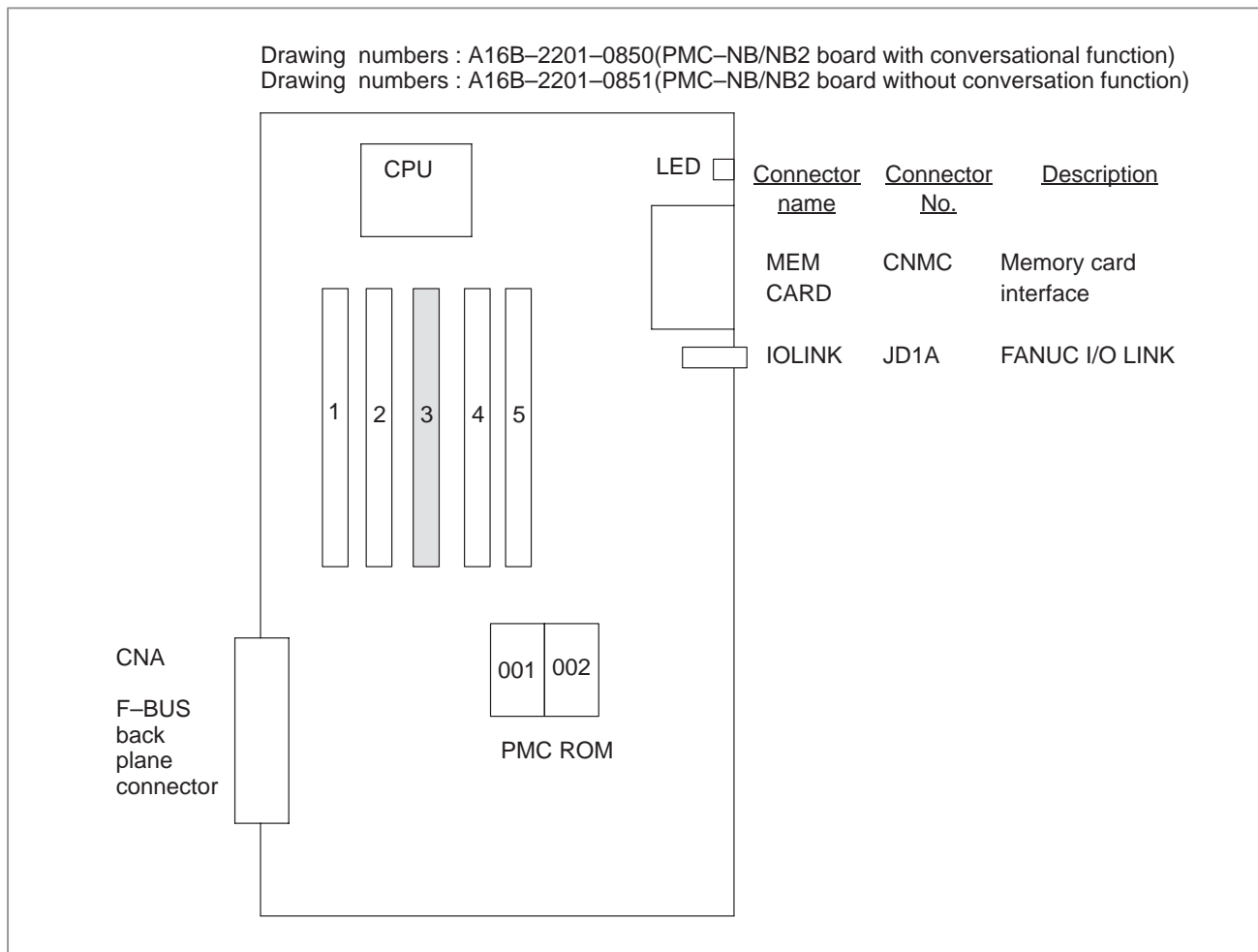

No.	Module name	Function outline
1	ROM module	System ROM for conversational function
2	Conversational CPU module	CPU module for conversational function
3	Memory module (DRAM/SRAM)	Work memory for conversational function + Sub-memory for conversational function (TFB/TTFB)
4	DRAM module	Work memory for PMC CPU
5	PMC engine module	PMC operation control, I/D Link control

WARNING
 The shaded module () is connected to a power supply for battery backup. If that power supply is disconnected, the backup data may be lost. The memory module uses battery backup with 15-TFB, 15-TTFB, and 15TEF only.

● **Block diagram**

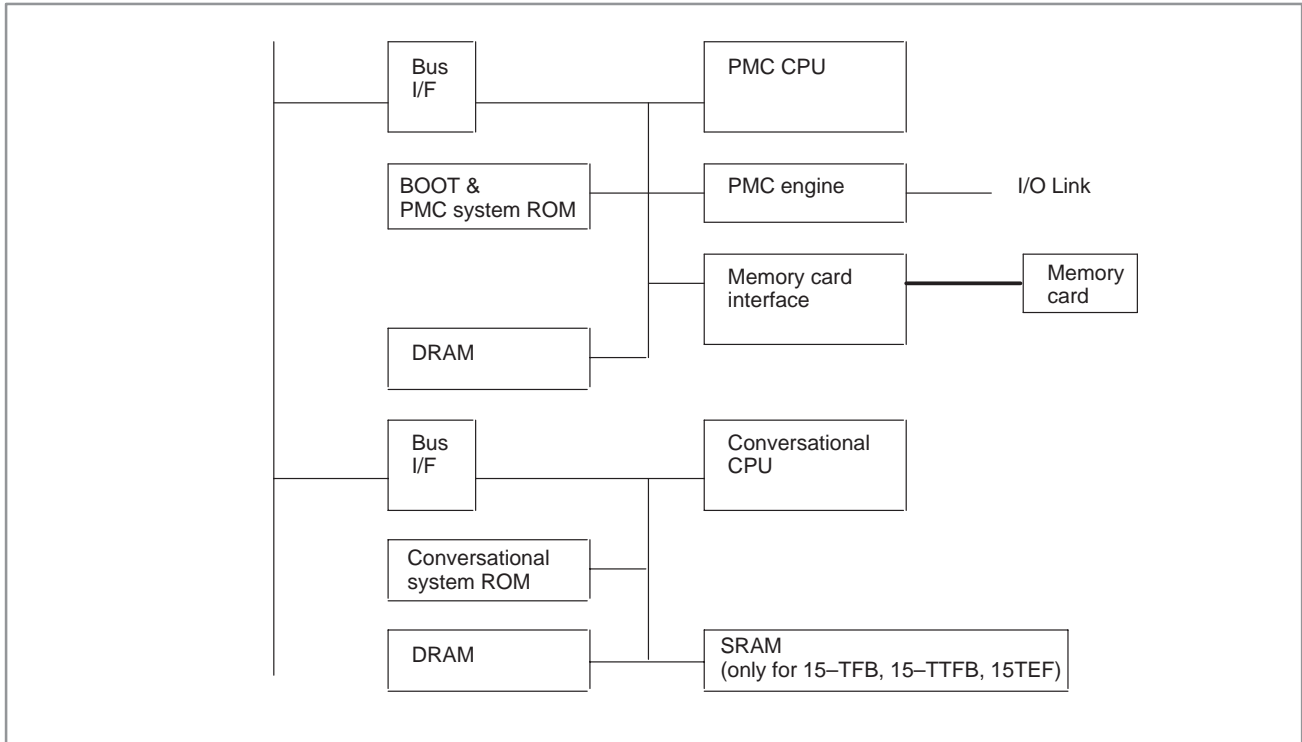

(1) Adjustment

No adjustment is needed.

(2) LED display

The STATUS LEDs at the top of the front of the PMC-NB board having the conversational function are used for independent functions, as shown on the right.

Legend

- : Not lit ■ : Lit ☆☆ : Blinking ◆ : Irrelevant
- ☆☆ represents that the two LEDs blink simultaneously.
- ★☆ represents that the two LEDs blink alternately.

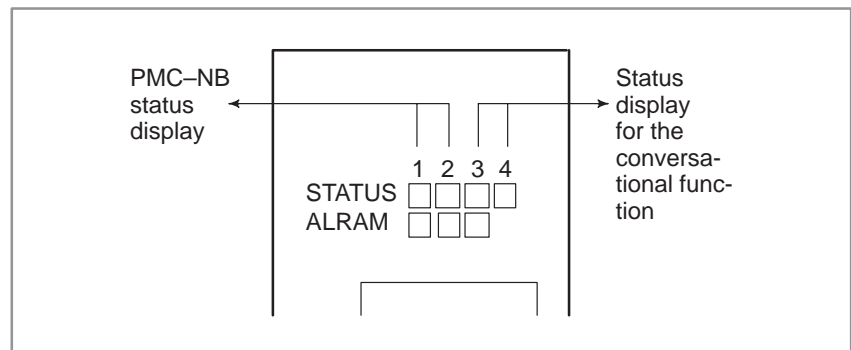

(a) LED display for the PMC–NB function

1. STATUS LED display transition when the power is turned on

No.	LED display	NC status
1	STATUS □□□□	Power-off
2	STATUS ■■◆◆	Initial state immediately after power-on or the state in which the PMC CPU is not operating
3	STATUS □■◆◆	Initial state. PMC initialization is in progress.
4	STATUS ■□◆◆	Initial state PMC ROM parity check, transfer of a Ladder or PASCAL program to DRAM in progress, SLC initialization in progress (IPL is completed in the CNC and the NC ready status is awaited.)
5	STATUS □□◆◆	Normal state

2. STATUS LED display for the PMC–NB function when an error occurs

No.	LED display	NC status
1	STATUS ★★◆◆	An error occurred in another PC board.
2	STATUS ■★◆◆	An error occurred during transfer to or from DI/DO. The DRAM module module on the main CPU board is defective. The PMC system ROM module is defective.
3	STATUS ★■◆◆	A RAM parity error occurred in the PMC engine module (during access to the PMP).
4	STATUS □★◆◆	A RAM parity error occurred in the PMC engine module or PMC DRAM (during access to the CPU).(Note)
5	STATUS ★☆◆◆	A failure (BUS ERR, INVALID OPCODE, etc.) occurred in the PMC function. The PMC ROM is defective.

(b) STATUS LED display for the conversational function (15-TFB, 15-TTFB, 15-MFB, 15TEF)

1. STATUS LED display transition when the power is turned on

No.	LED display	NC status
1	STATUS □□□□	Power-off
2	STATUS ◆◆□■	Waiting for initialization of the main CPU (waiting for ID setting)
3	STATUS ◆◆■□	Initialized state
4	STATUS ◆◆□□	Normal state

2. STATUS LED display for the conversational function when an error occurs (15-TFB, 15-TTFB, 15TEF)

No.	LED display	NC status
1	STATUS ◆◆★★	An error occurred in another PC board.
2	STATUS ◆◆□★	A RAM parity error occurred on the PC board for the conversational function.
3	STATUS ◆◆★☆	A defective ROM module was detected on the PC board for the conversational function.
4	STATUS ◆◆■□	The CPU for the conversational function performed illegal processing.

3. STATUS LED display for the conversational function when an error occurs (15-MFB)

No.	LED display	NC status
1	STATUS ◆◆★★	An error occurred in another PC board or the CPU for the conversational function.

(c) ALARM LED display

No.	LED display	NC status
1	ALARM ■□□	The CPU for the conversational function asserts SYSFAIL.
2	ALARM □■□	The PMC CPU asserts SYSFAIL.
3	ALARM ■■□	The PMC CPU is in the stop state.
4	ALARM □□■	An error occurred in data transfer to or from DI/DO. (SLC ERROR)
5	ALARM □■■	A DRAM parity error occurred on the PMC side (Note).
6	ALARM ■■■	A RAM parity error occurred in RAM of the PMC engine module.

NOTE

DRAM is mounted on the PMC-NB/NB2 board and DRAM module.

2.5.11**Configuration of the
Axis CPU Board
(ACPU)**

(1) Parts layout

Drawing number : A16B-2201-0360

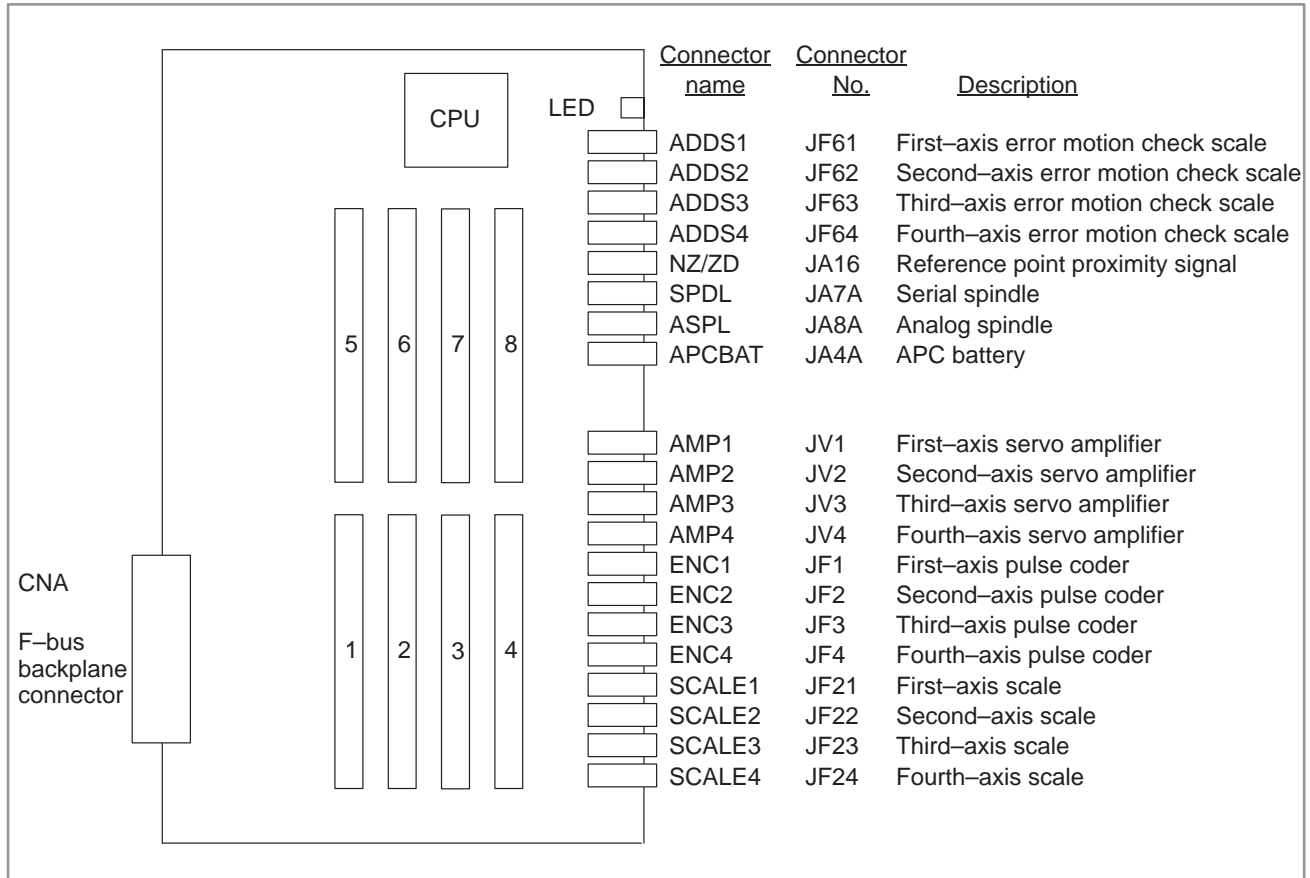

No.	Module name	Function outline
1	Servo control module	Third-axis and fourth-axis servo control
2	Servo control module	First-axis and second-axis servo control
3	Servo interface module	Third-axis and fourth-axis amplifier, pulse coder interface
4	Servo interface module	First-axis and second-axis amplifier, pulse coder interface
5	DRAM module	RAM for the axis CPU system
6	Error motion check module	First-axis and second-axis error motion check interface
7	Error motion check module	Third-axis and Fourth-axis error motion check interface
8	Spindle control module	Spindle control, reference point proximity signal interface

(2) Block diagram

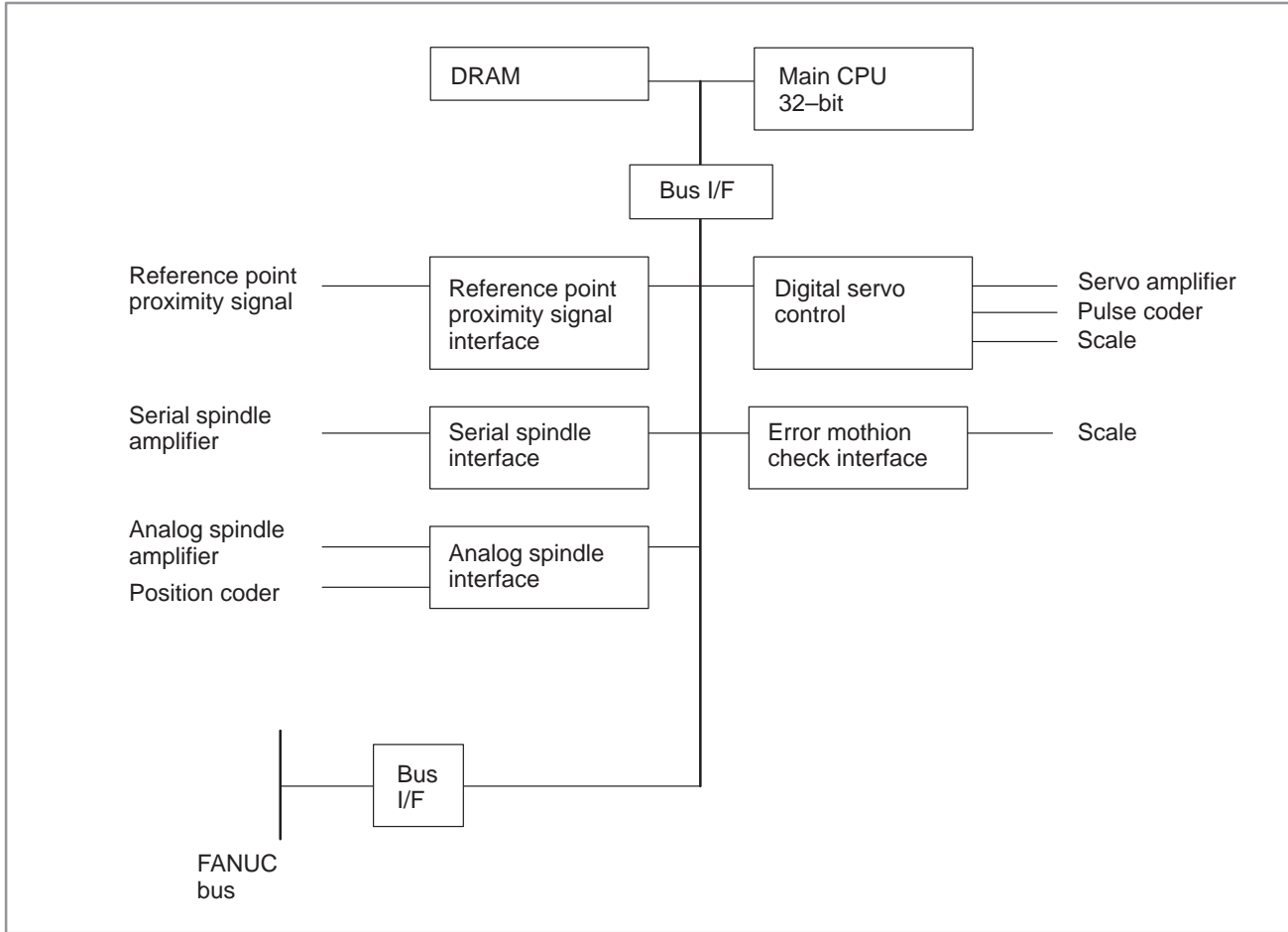

(3) Adjustment

No adjustment is needed.

(4) LED display

□ : Not lit ■ : Lit ★ : Blinking

STATUS LEDs are green. ALARM LEDs are red.

1. LED display transition when the power is turned on (STATUS LED)

No.	LED display	NC status
1	STATUS □□□□	Power-off
2	STATUS ■■■■	State in which the axis CPU is not started
3	STATUS ■□□■	Beginning of the activation of the axis CPU software
4	STATUS □□□■	End of the axis CPU local RAM test
5	STATUS ■■■□	End of the axis CPU local RAM clear
6	STATUS □■■□	Waiting for a response from the main CPU (1)
7	STATUS ■□■□	Waiting for a response from the main CPU (2)
8	STATUS □□■□	Waiting for a response from the main CPU (3)
9	STATUS ■■□□	Waiting for a response from the digital servo
10	STATUS □■□□	Waiting for a response from the main CPU (4)
15	STATUS ■□□□	Normal state. The power-on sequence is ended.

2. LED display when an error occurs (STATUS LED)

No.	LED display	NC status
1	STATUS ★□□□	An error occurred in the DRAM of the axis CPU.
2	STATUS □★□□	An unsupported component is installed in the DRAM of the axis CPU.
3	STATUS □★★□	A logical slot setting error occurred.
16	STATUS □■■■■	A system error occurred.

3. LED display when an error occurs (ALARM LED)

No.	LED display	NC status
2	ALARM □■□	SYSFAIL (fault in a module on the F-BUS) occurred.
3	ALARM ■■□	A servo alarm occurred.
4	ALARM □□■	SYSEMG (NMI in a module on the F-BUS) occurred.
5	ALARM ■□■	A bus error occurred (F-BUS, servo, spindle module).
6	ALARM □■■	A parity alarm occurred in the DRAM module.

2.5.12 Configuration of the Multiaxis Buffer Board

(1) Parts layout

Drawing number : A16B-2201-0351

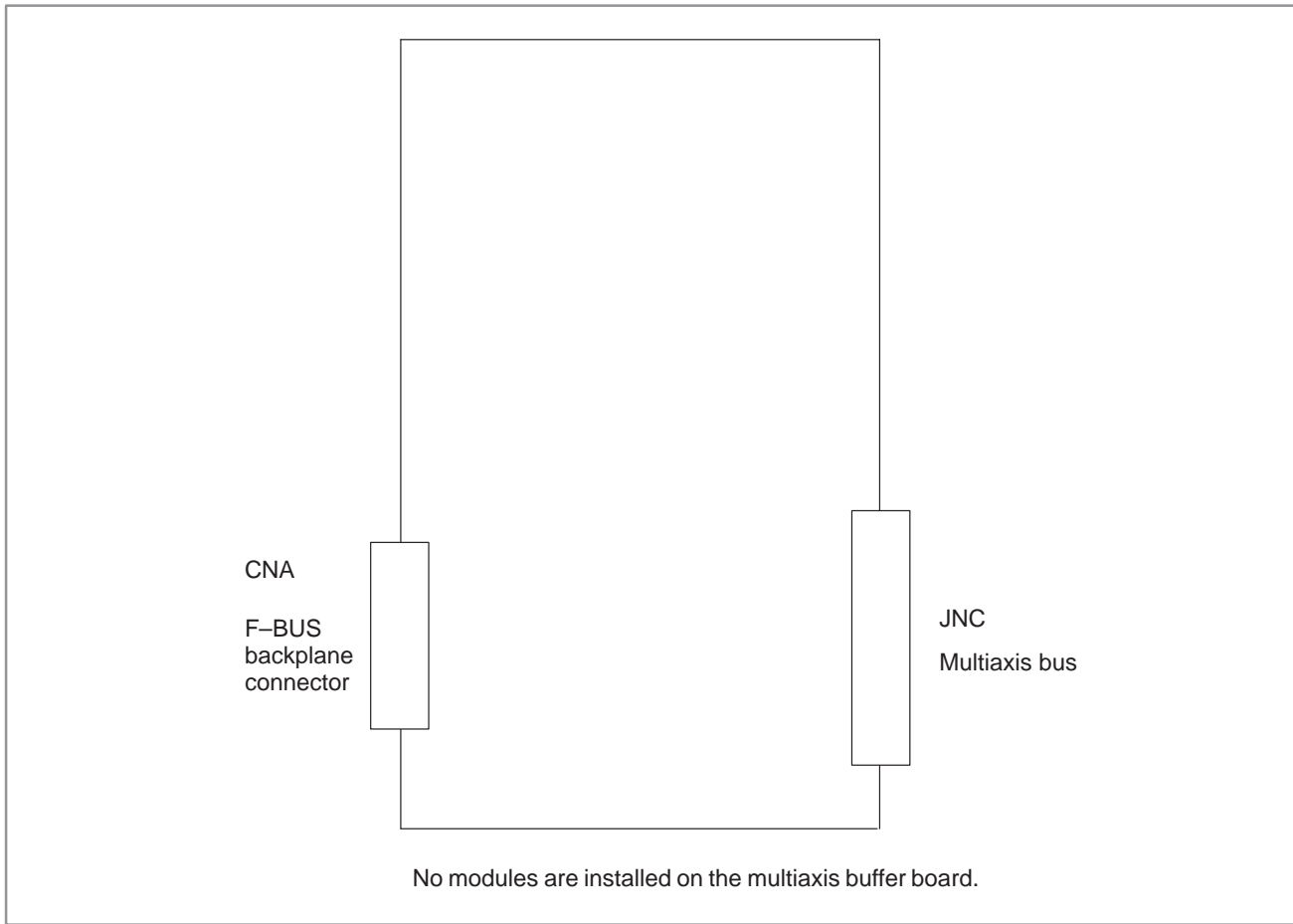

(2) Block diagram

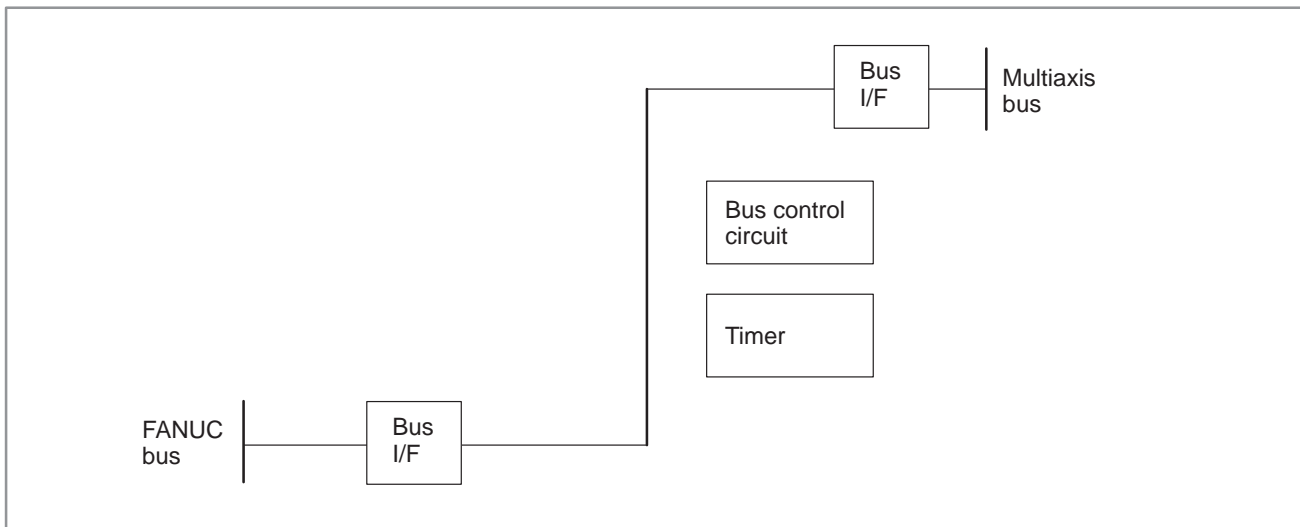

(3) Adjustment

No adjustment is needed.

(4) LED display

□ : Not lit ■ : Lit ★ : Blinking

STATUS LEDs are green. ALARM LEDs are red.

1.2. The STATUS LEDs (green LEDs) on this PC board have no meaning.

3. LED display when an error occurs (ALARM LED)

No.	LED display	NC status
1	ALARM □■□	SYSFAIL occurred in the axis shelf. (A fault occurred in a module of the axis shelf.)
2	ALARM □■■■	SYSEMG occurred in the axis shelf. (An NMI occurred in a module of the axis shelf.)
3	ALARM ■□■	A bus error occurred during write access from the main shelf.
4	ALARM ■■■□	A bus error occurred in the F-bus of the axis shelf.

2.5.13

Configuration of the RISC Board

(1) Parts layout

Drawing number : A16B-2201-0710/02A and on

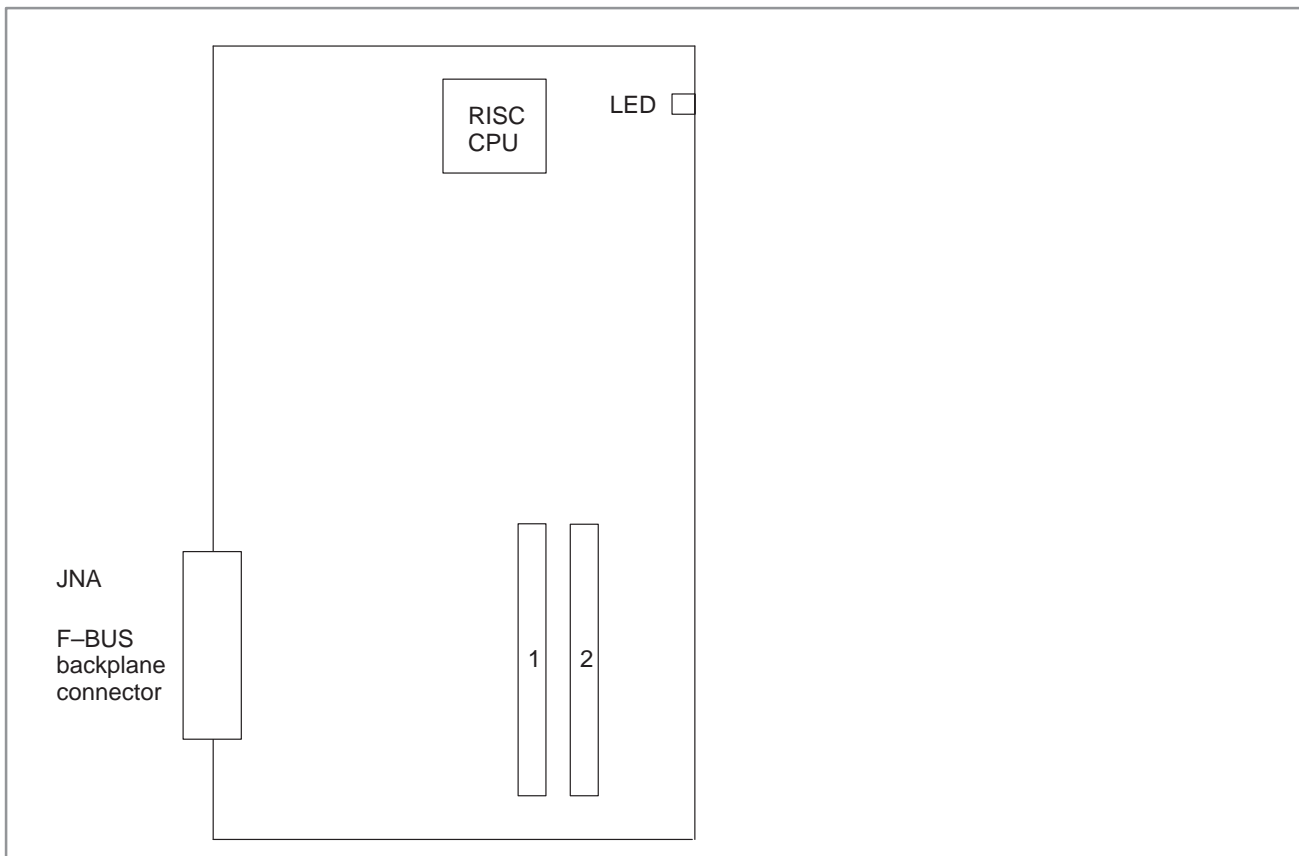

No.	Module name	Function outline
1	SRAM module	For SHARED RAM
2	ROM module	Memory for RISC CPU

NOTE
RISC board can not be used in Series 15MEK/MEL/TED/TEE/TEF-B-4.

(2) Block diagram

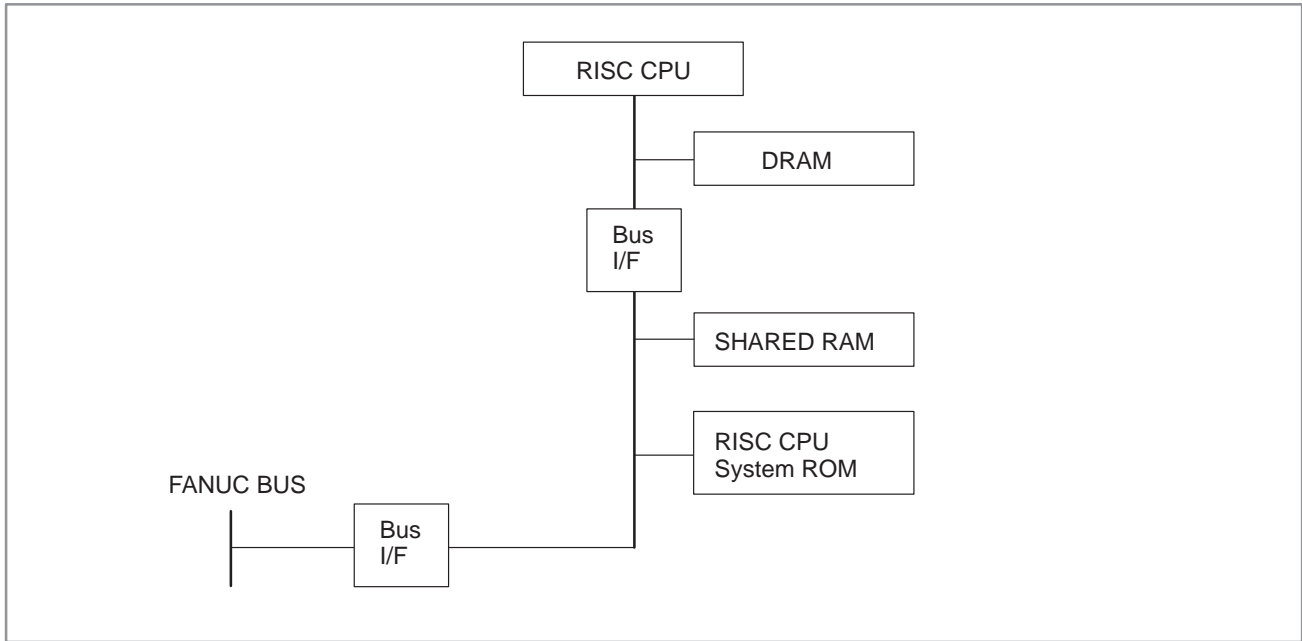

(3) Adjustment

No adjustment is needed.

(4) LED display

□ : Not lit ■ : Lit ★ : Blinking

STATUS LEDs are green. ALARM LEDs are red.

- LED display when the power is turned on (Nos.1 to 8) and during operation (Nos. 9 to 12) (STATUS LED)

No.	LED display	NC status
1	STATUS □□□□	Power-off
2	STATUS ■■■■	Immediately after power-on or the state in which the RISC CPU is not started
3	STATUS □□□■	DRAM or SHARED RAM test in progress (If an error is detected during the test, this LED display is held and not changed.)
4	STATUS □□■□	ROM test in progress (If an error is detected during the test, this LED display is held and not changed.)
5	STATUS ■□□□	Waiting for the processing by the CNC (1)
6	STATUS ■□□■	Waiting for the processing by the CNC (2)
7	STATUS ■□■□	Waiting for the processing by the CNC (3)
8	STATUS ■■□□	Waiting for the processing by the CNC (4)
9	STATUS □□□★	Waiting for RISC mode
10	STATUS □★□★	Waiting for the input of an NC statement
11	STATUS □★★□	Executing a command in RISC mode
12	STATUS ★□□□	Resetting
13	STATUS ★□★★	Override 0 upon acceleration/deceleration before interpolation (waiting for an override change)

- LED display when an error occurs (STATUS LED)

No.	LED display	NC status
1	STATUS □□□■	An error occurred during test of the DRAM or SRAM module (shared RAM) on the RISC board.
2	STATUS □□■□	An error occurred during test of the ROM module.
3	STATUS □□■■■	A synchronization signal cannot be detected from the main CPU.
4	STATUS □■□□	An error occurred during access to the F-bus. (The module ID cannot be read correctly.)
5	STATUS ■■■□	A system error occurred.

- LED display when an error occurs (ALARM LED)

No.	LED display	NC status
1	ALARM ■□□	The RISC CPU is not started.
2	ALARM □■□	A parity alarm occurred in the SRAM module.
3	ALARM □□■	A parity alarm occurred in the DRAM on the RISC board.

2.5.14 Configuration of the RISC Board

(1) Parts layout

Drawing number : A16B-3200-0150/0313 and on

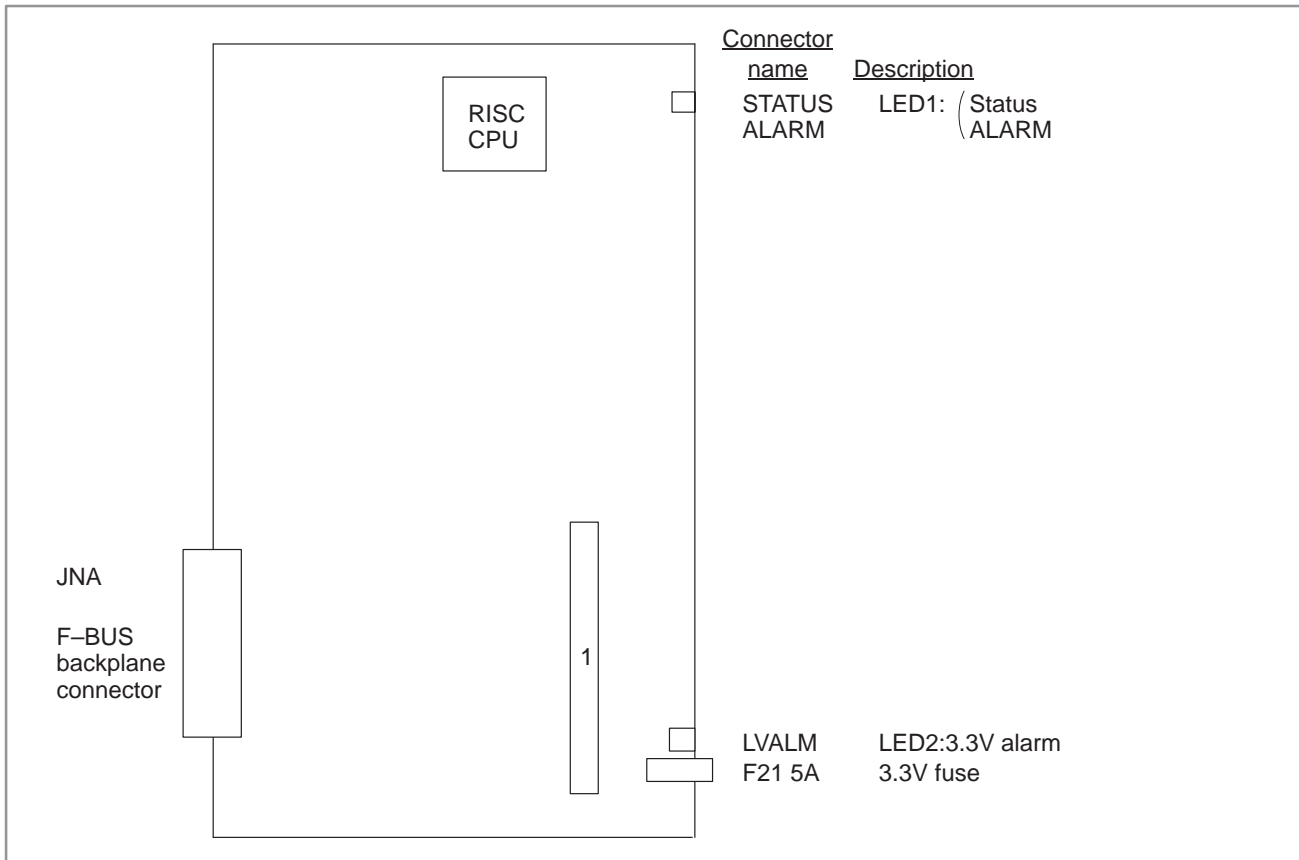

No.	Module name	Function outline
1	ROM module	Memory for RISC CPU

NOTE
RISC board can not be used in Series 15MEK/MEL/TED/TEE/TEF-B-4.

(2) Block diagram

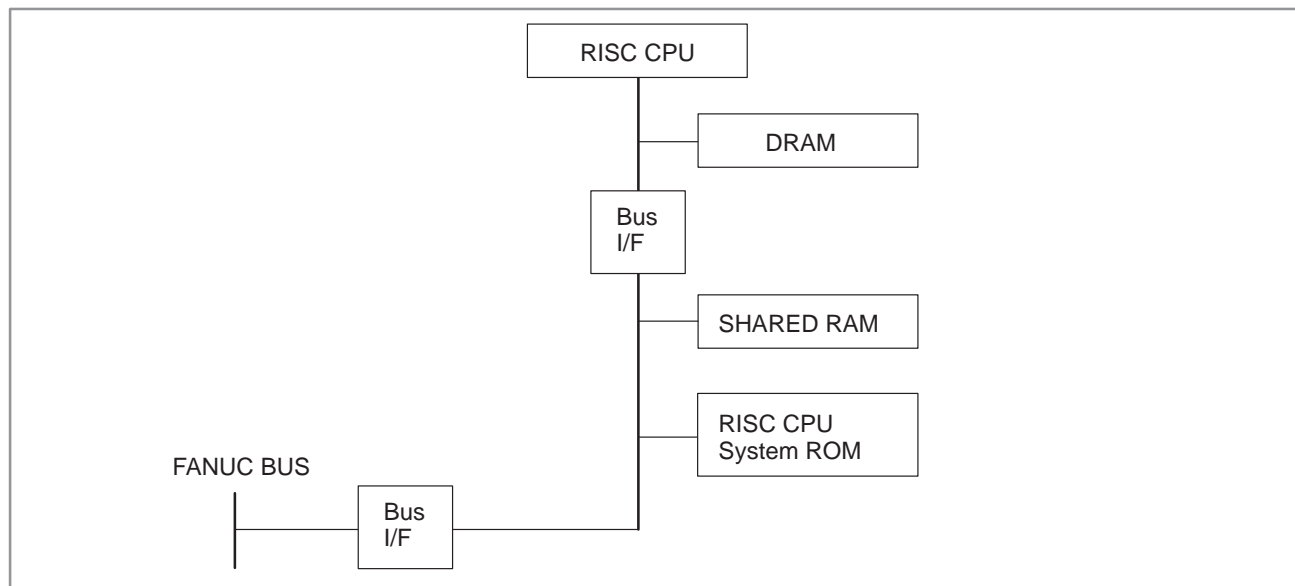

(3) Adjustment

No adjustment is needed.

(4) LED display

(a) LED1

□ : Not lit ■ : Lit ★ : Blinking

STATUS LEDs are green. ALARM LEDs are red.

- LED display when the power is turned on (Nos.1 to 8) and during operation (Nos. 9 to 12) (STATUS LED)

No.	LED display	NC status
1	STATUS □□□□	Power-off
2	STATUS ■■■■	Immediately after power-on or the state in which the RISC CPU is not started
3	STATUS □□□■	DRAM or SHARED RAM test in progress (If an error is detected during the test, this LED display is held and not changed.)
4	STATUS □□■□	ROM test in progress (If an error is detected during the test, this LED display is held and not changed.)
5	STATUS ■□□□	Waiting for the processing by the CNC (1)
6	STATUS ■□□■	Waiting for the processing by the CNC (2)
7	STATUS ■□■□	Waiting for the processing by the CNC (3)
8	STATUS ■■□□	Waiting for the processing by the CNC (4)
9	STATUS □□□★	Waiting for RISC mode
10	STATUS □★□★	Waiting for the input of an NC statement
11	STATUS □★★□	Executing a command in RISC mode
12	STATUS ★□□□	Resetting
13	STATUS ★□★★	Override 0 upon acceleration/deceleration before interpolation (waiting for an override change)

2. LED display when an error occurs (STATUS LED)

No.	LED display	NC status
1	STATUS □□□■	An error occurred during test of the DRAM or SRAM module (shared RAM) on the RISC board.
2	STATUS □□■□	An error occurred during test of the ROM module.
3	STATUS □□■■	A synchronization signal cannot be detected from the main CPU.
4	STATUS □■□□	An error occurred during access to the F-bus. (The module ID cannot be read correctly.)
5	STATUS ■■■□	A system error occurred.

3. LED display when an error occurs (ALARM LED)

No.	LED display	NC status
1	ALARM ■□□	The RISC CPU is not started.
2	ALARM □■□	A parity alarm occurred in the SRAM.
3	ALARM □□■	A parity alarm occurred in the DRAM on the RISC board.

(b)LED2

4. LED2 (LV ALM) display

No.	LED display	NC status
1	LV ALM ■(Red)	The output voltage of the 3.3V power supply exceeded the specified range.

- Fuse F21

This fuse may blow if the 3.3V power supply or a 3.3V device suffers a serious failure.

2.5.15 Configuration of the Sub-CPU Board (SUB-A)

(1) Parts layout

Drawing number : A16B-2201-0310

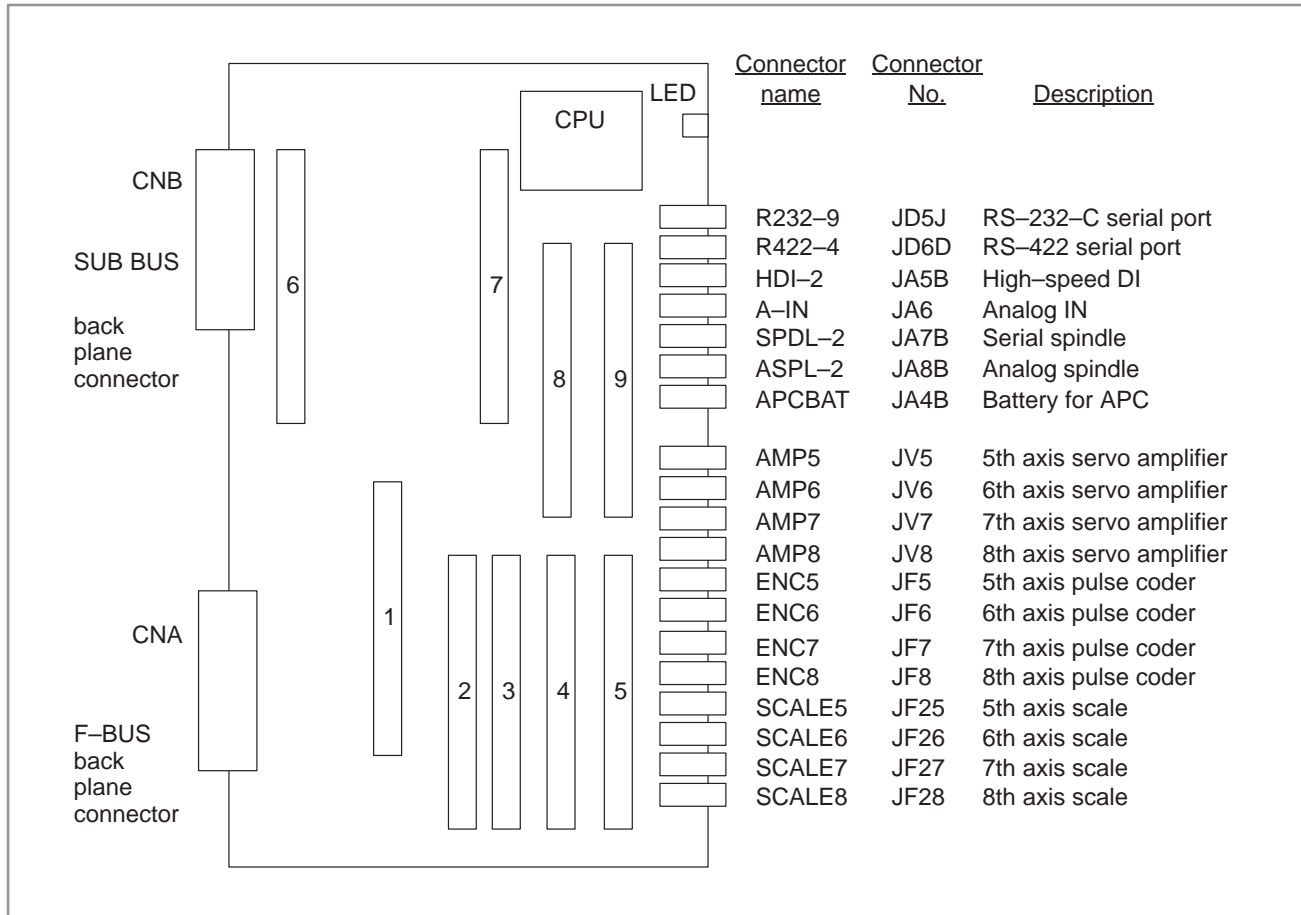

No.	Module name	Function outline
1	SRAM module	For SHARED RAM
2	Servo control module	7th and 8th servo control
3	Servo control module	5th and 6th servo control
4	Servo interface module	7th and 8th amplifier, pulse coder interface
5	Servo interface module	5th and 6th amplifier, pulse coder interface
6	High-speed SRAM module	High-speed RAM for sub.system
7	DRAM module	RAM for sub.system
8	2nd spindle control module	2nd spindle control, HDI interface etc...
9	Analog IN & Serial communication module	Input of analog, RS-232C, RS-422 interface

(2) Block diagram

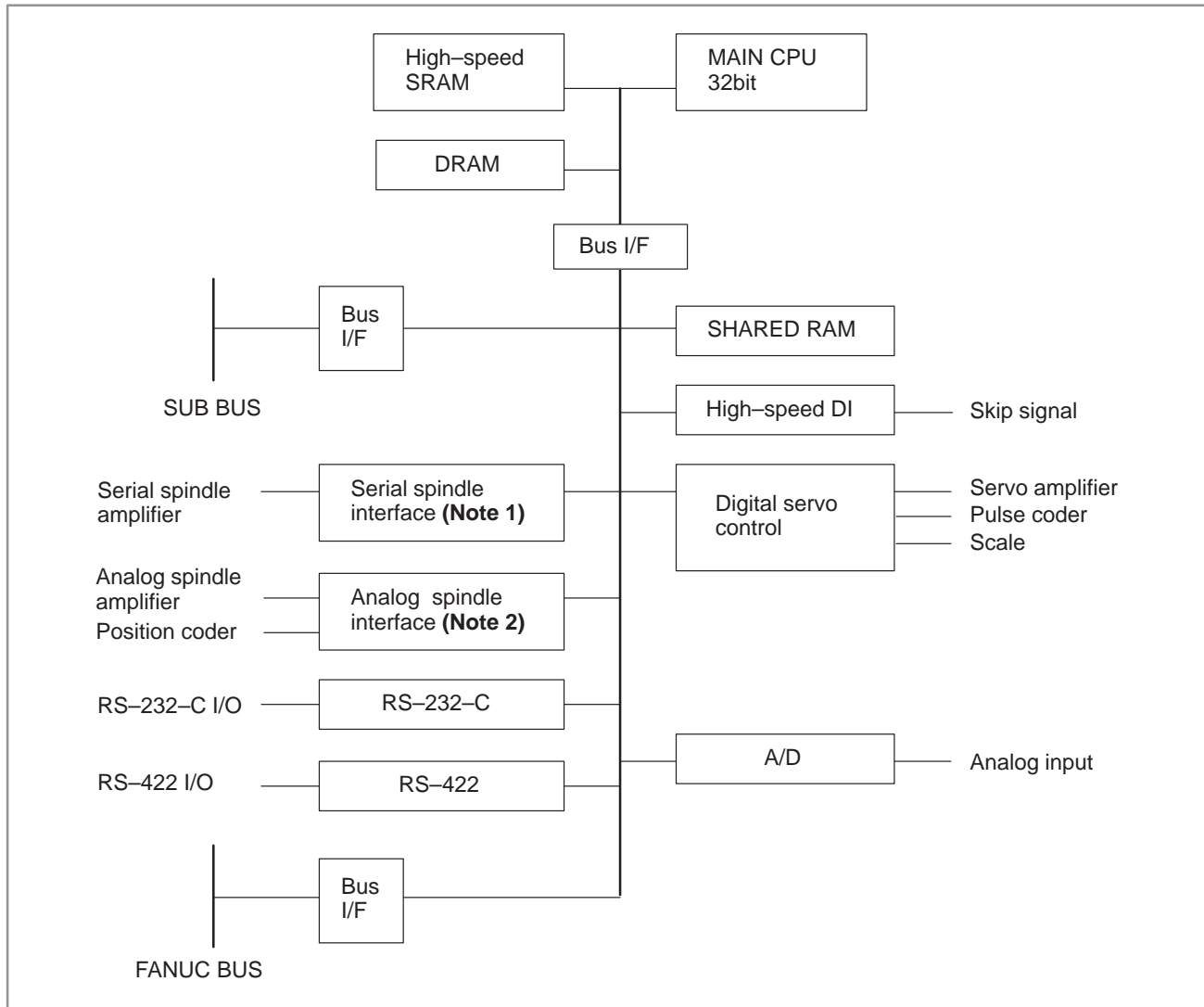
**NOTE**

- 1 When the module of analog spindle is built in as a module of spindle control, the serial spindle interface is not there.
- 2 When a serial spindle module is mounted as the spindle control module, an analog spindle interface is not used.

(3) Adjustment

No adjustment is needed.

(4) LED display

□ : Not lit ■ : Lit ★ : Blinking

STATUS LEDs are green. ALARM LEDs are red.

1. LED display transition when the power is turned on
(STATUS LED)

No.	LED display	NC status
1	STATUS □□□□	Power-off
2	STATUS ■■■■	Initial state immediately after power-on
3	STATUS ■□□■	State in which the sub-CPU software is to be activated
4	STATUS □□□■	Beginning of the activation of the sub-CPU software
5	STATUS ■■■□	Beginning of the sub-CPU local RAM test
6	STATUS □■■□	End of the sub-CPU local RAM test
7	STATUS ■□■□	End of initialization of a custom LSI chip
8	STATUS □□■□	Beginning of the internal processing of the sub-CPU
9	STATUS ■■□□	Waiting for the processing by the main CPU (1)
10	STATUS □■□■	Waiting for the processing by the main CPU (2)
11	STATUS ■□□□	Normal state. The power-on sequence has ended.

2. LED display when an error occurs (STATUS LED)

No.	LED display	NC status
1	STATUS ★□★★	An error occurred in the local RAM of the sub-CPU.
16	STATUS □■■■	A system error occurred.

3. LED display when an error occurs (ALARM LED)

No.	LED display	NC status
1	ALARM ■□□	The sub-CPU is not started.
2	ALARM □■□	SYSFAIL (fault in a module on the F-bus) occurred.
3	ALARM ■■□	A servo alarm occurred.
4	ALARM □□■	SYSEMG (NMI in a module on the F-bus) occurred.
5	ALARM ■□■	An ABC alarm (parity alarm in shared RAM, fault in the peripheral bus, SUB bus, FANUC bus) occurred.
6	ALARM □■■	A parity alarm occurred in the DRAM module.
7	ALARM ■■■	A parity alarm occurred in the high-speed SRAM module.

2.5.16
Configuration of the
Standard Multiaxis
Sub-CPU Board
(MAX SUB-B)

(1) Parts layout

Drawing number : A16B-2201-0331

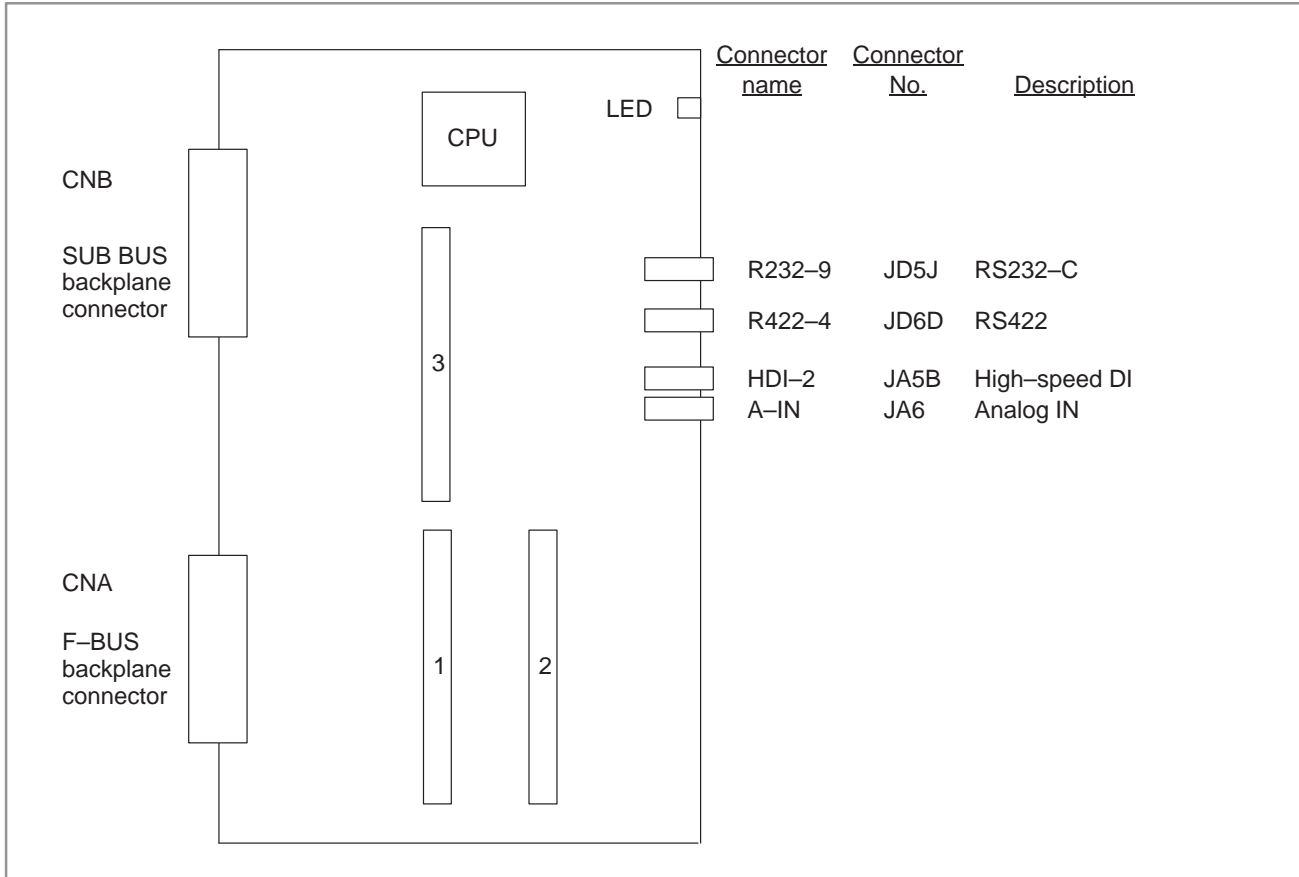

No.	Module name	Function outline
1	SRAM module	For SHARED RAM
2	Analog IN and serial communication module	Analog input, RS-232C and RS-422 interface
3	DRAM module	RAM for subsystem

(2) Block diagram

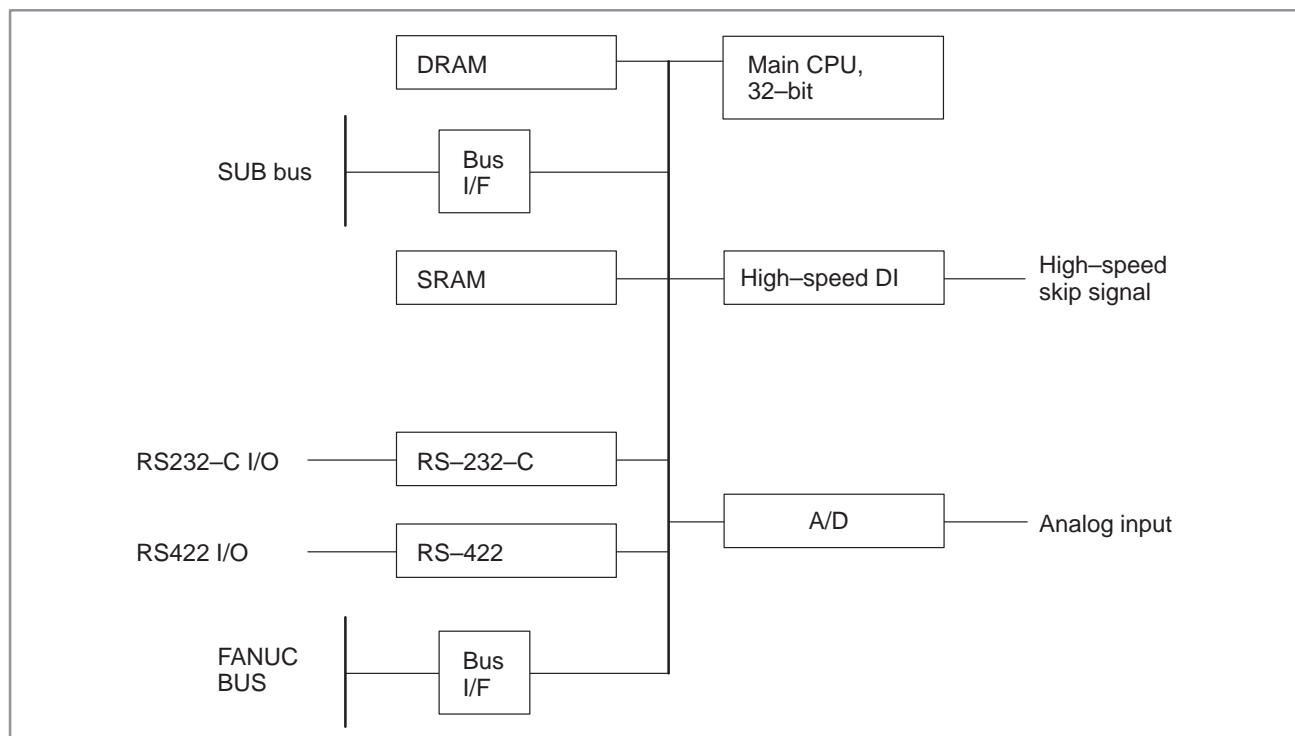

(3) Adjustment

No adjustment is needed.

(4) LED display

□ : Not lit ■ : Lit ★ : Blinking

STATUS LEDs are green. ALARM LEDs are red.

1. LED display transition when the power is turned on
(STATUS LED)

No.	LED display	NC status
1	STATUS □□□□	Power-off
2	STATUS ■■■■	Initial state immediately after power-on
3	STATUS ■□□■	State in which the sub-CPU software is to be activated
4	STATUS □□□■	Beginning of the activation of the sub-CPU software
5	STATUS ■■■□	Beginning of the sub-CPU local RAM test
6	STATUS □■■□	End of the sub-CPU local RAM test
7	STATUS ■□■□	End of initialization of a custom LSI chip
8	STATUS □□■□	Beginning of sub-CPU's internal processing
9	STATUS ■■□□	Waiting for the processing by the main CPU (1)
10	STATUS □■□■	Waiting for the processing by the main CPU (2)
11	STATUS ■□□□	Normal state. The power-on sequence is ended

2. LED display when an error occurs (STATUS LED)

No.	LED display	NC status
1	STATUS ★□★★	An error occurred in the local RAM of the sub-CPU.
2	STATUS □■██	A system error occurred.

3. LED display when an error occurs (ALARM LED)

No.	LED display	NC status
1	ALARM □■□	SYSFAIL (fault in a module on the F-bus) occurred.
2	ALARM ■■□	A servo alarm occurred.
3	ALARM □□■	SYSEMG (NMI in a module on the F-bus) occurred.
4	ALARM ■□■	An ABC alarm (parity alarm in the shared RAM, fault in the peripheral bus, SUB bus, FANUC bus) occurred.
5	ALARM □■■	A parity alarm occurred in the DRAM module.

2.5.17

(1) Parts layout

Configuration of the Upgraded Sub-CPU Board (SUB-C)

Drawing number : A16B-2202-0571

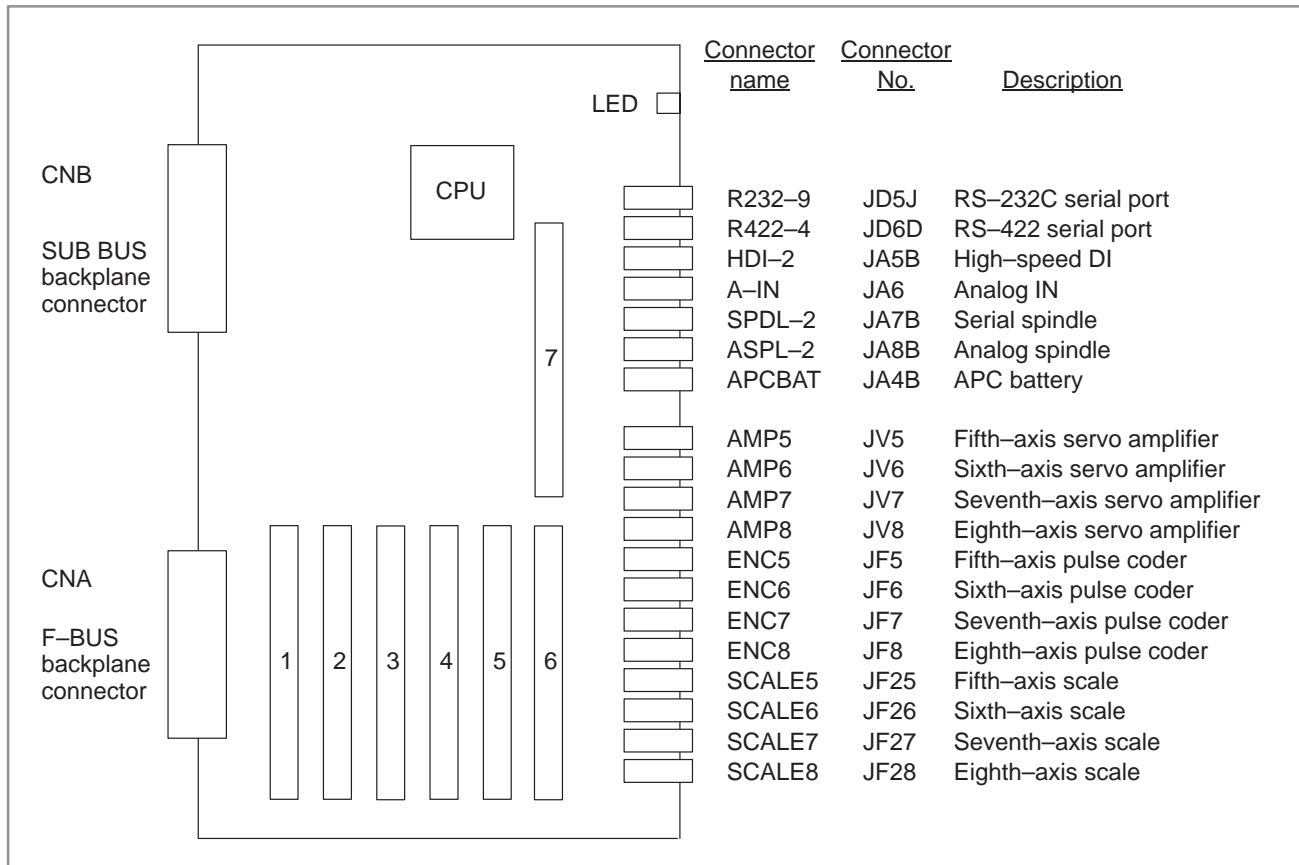

No.	Module name	Function outline
1	Analog IN & serial communication module	Analog input, RS-232C and RS-422 interface
2	Second spindle control module	Second spindle control, HDI interface, etc.
3	Servo control module	Seventh-axis and eighth-axis servo control
4	Servo control module	Fifth-axis and sixth-axis servo control
5	Servo interface module	Seventh-axis and eighth-axis servo amplifier, pulse coder interface
6	Servo interface module	Fifth-axis and sixth-axis servo amplifier, pulse coder interface
7	DRAM module	RAM for subsystem

(2) Block diagram

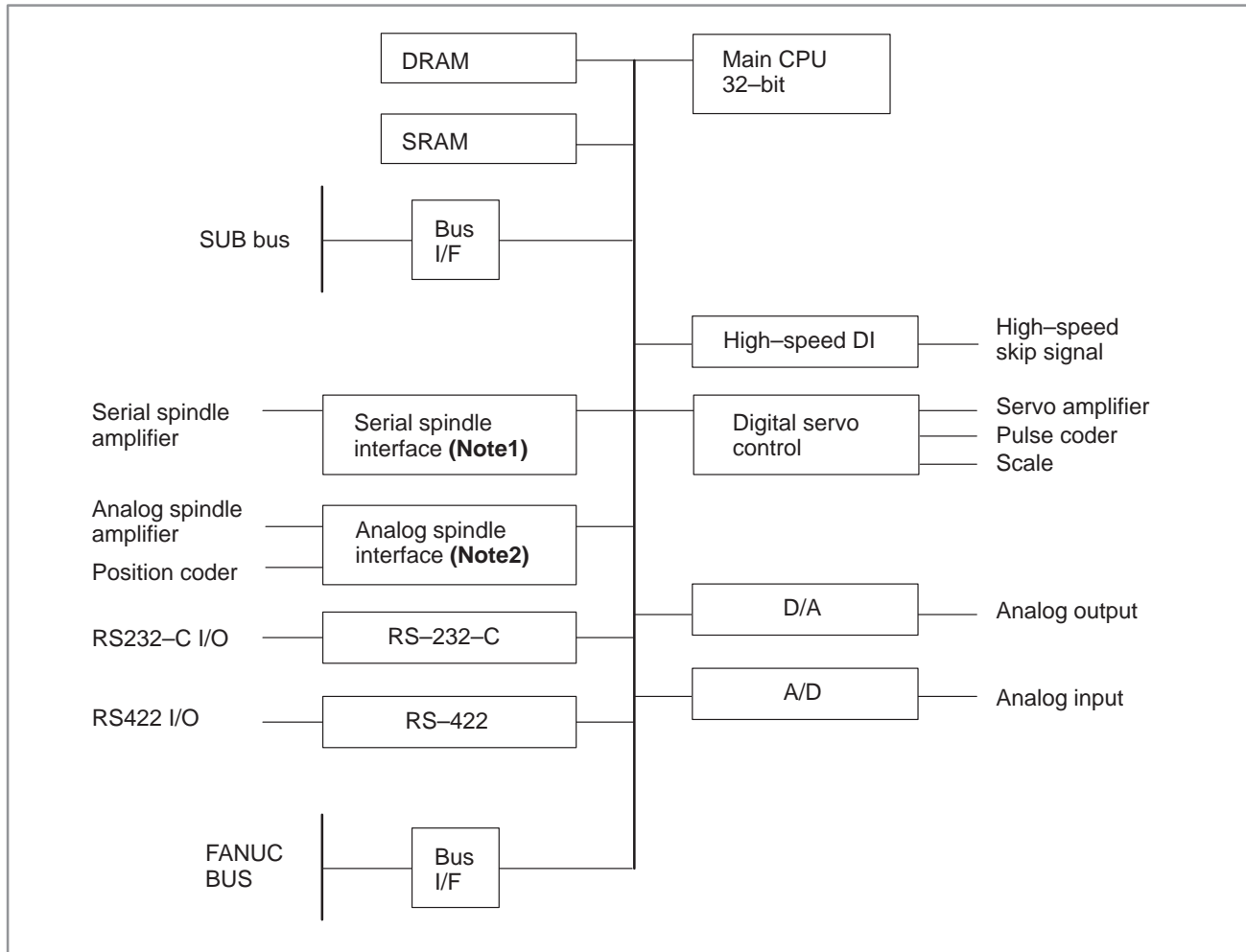
**NOTE**

- 1 If the analog spindle module is mounted as the spindle control module, the serial spindle interface is not included.
- 2 If the serial spindle module is mounted as the spindle control module, the analog spindle interface is not included.

(3) Adjustment

No adjustment is needed.

(4) LED display

□ : Not lit ■ : Lit ★ : Blinking

STATUS LEDs are green. ALARM LEDs are red.

1. LED display transition when the power is turned on
(STATUS LED)

No.	LED display	NC status
1	STATUS □□□□	Power-off
2	STATUS ■■■■	Initial state immediately after power-on
3	STATUS ■□□■	State in which the sub-CPU software is to be activated
4	STATUS □□□■	Beginning of the activation of the sub-CPU software
5	STATUS ■■■□	Beginning of the sub-CPU local RAM test
6	STATUS □■■□	End of the sub-CPU local RAM test
7	STATUS ■□■□	End of initialization of a custom LSI chip
8	STATUS □□■□	Beginning of the sub-CPU's internal processing
9	STATUS ■■□□	Waiting for the processing by the main CPU (1)
10	STATUS □■□■	Waiting for the processing by the main CPU (2)
11	STATUS ■□□□	Normal state. The power-on sequence has ended.

2. LED display when an error occurs (STATUS LED)

No.	LED display	NC status
1	STATUS ★□★★	An error occurred in the local RAM of the sub-CPU.
16	STATUS □■■■	A system error occurred.

3. LED display when an error occurs (ALARM LED)

No.	LED display	NC status
1	ALARM ■□□	The sub-CPU has not started.
2	ALARM □■□	SYSFAIL (fault in a module on the F-bus) occurred.
3	ALARM ■■□	A servo alarm occurred.
4	ALARM □□■	SYSEMG (NMI in a module on the F-bus) occurred.
5	ALARM ■□■	An ABC alarm (fault in the peripheral bus, FANUC bus) occurred.
6	ALARM □■■	A parity alarm occurred in the DRAM module.
7	ALARM ■■■	A parity alarm occurred in the SRAM mounted on the sub-CPU.

2.5.18 Configuration of Additional Axis (ADAX) Board

(1) Parts layout

Drawing number : A16B-2201-0311

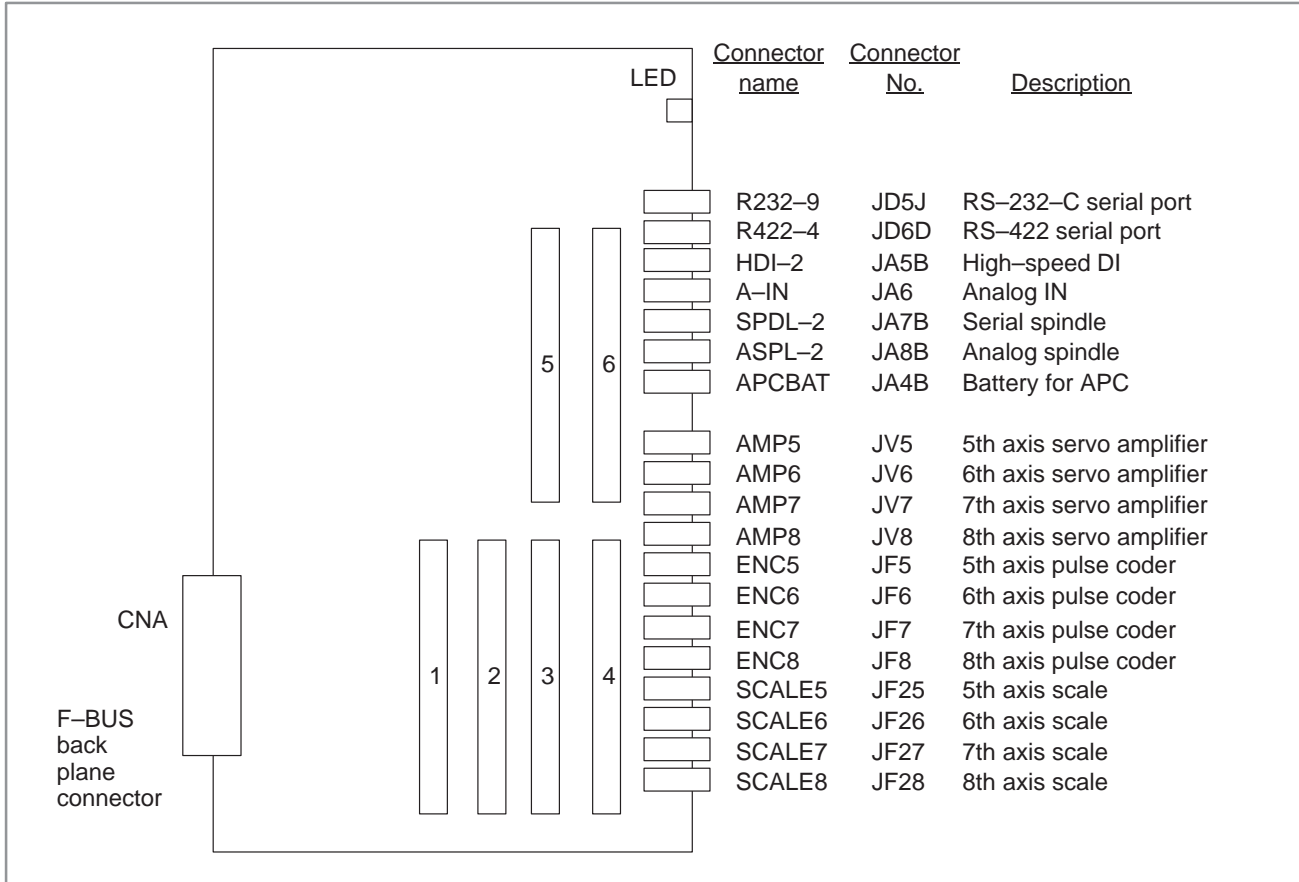

No.	Module name	Function outline
1	Servo control module	7th and 8th servo control
2	Servo control module	5th and 6th servo control
3	Servo interface module	7th and 8th amplifier, pulse coder interface
4	Servo interface module	5th and 6th amplifier, pulse coder interface
5	2nd spindle control module	2nd spindle control, HDI interface etc....
6	Analog IN & serial communications module	Input of Analog, RS-232C, RS-422 interface

(2) Block diagram

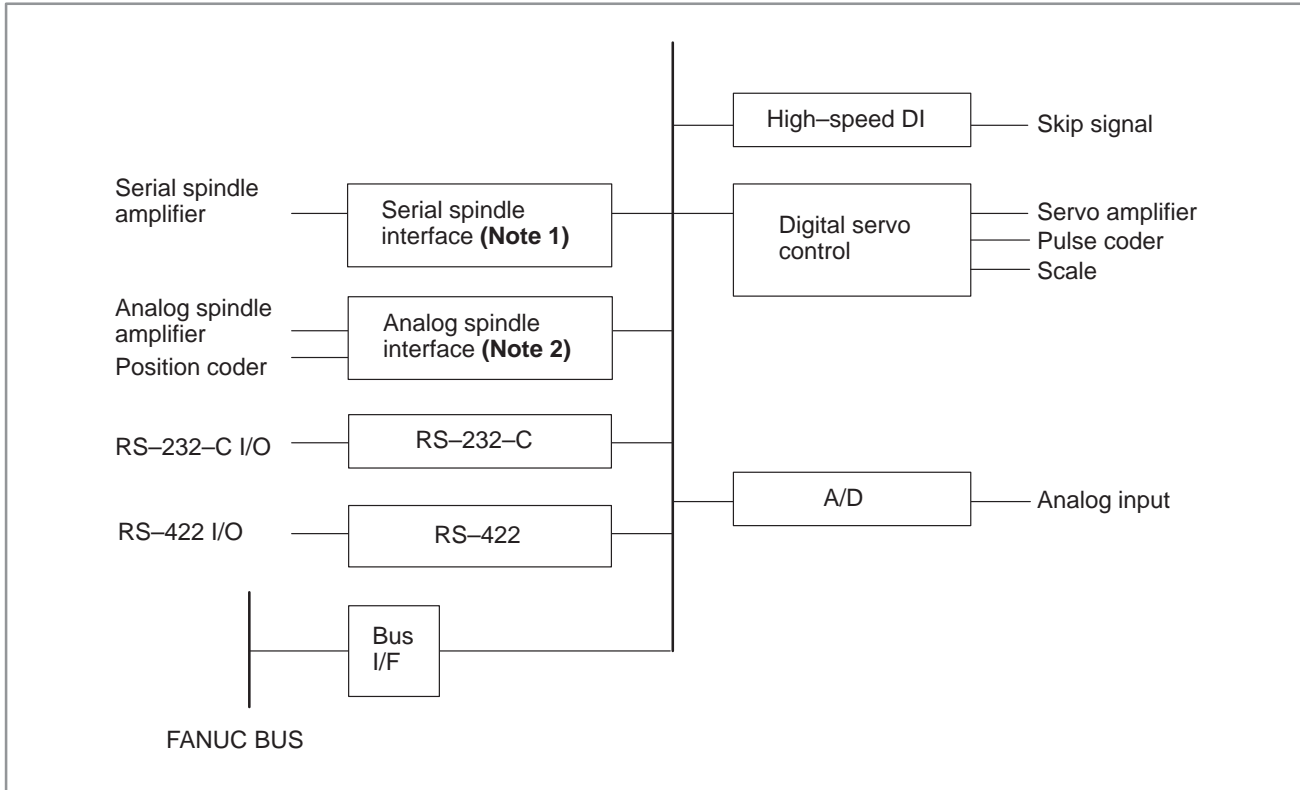
**NOTE**

- 1 When the module of analog spindle is built in as a module of spindle control, the serial spindle interface is not there.
- 2 When a serial spindle module is mounted as the spindle control module, an analog spindle interface is not used.

(3) Adjustment

No adjustment is needed.

(4) LED display

□ : Off ■ : Lit ★ : Flashing

The STATUS LEDs are green and the ALARM LEDs are red.

LED display when an error occurs (ALARM LED)

No.	LED display	NC status
1	ALARM ■□□	Not used
2	ALARM □■□	SYSFAIL (A fault occurred on some modules of F-BUS.)
3	ALARM ■■□	SERVO ALARM
4	ALARM □□■	SYSEMG (NMI occurred on some modules of F-BUS.)
5	ALARM ■□■	ABC ALARM (A fault of peripheral bus)
6	ALARM □■■	Not used
7	ALARM ■■■	Not used

NOTE

All the STATUS LED is always off

2.5.19 Configuration of the Option 1 Board

(1) Parts layout

Drawing number : A16B-2200-0910

(Remote buffer communication function + Graphic function)

: A16B-2200-0911

(DNC1 communication function+Graphic function RAM added)

: A16B-2200-0912 (Graphic function)

: A16B-2200-0913

(Remote buffer communication function)

: A16B-2200-0914

(DNC1 communication function)

: A16B-2200-0915

(Remote buffer communication function+Graphic function RAM added)

: A16B-2200-0916

(DNC1 communication function+Graphic function RAM added)

: A16B-2200-0917

(Graphic function RAM added)

: A16B-2200-0918

(Remote buffer communication function+Graphic function RAM added)

: A16B-2200-0919

(*Graphic function RAM added)

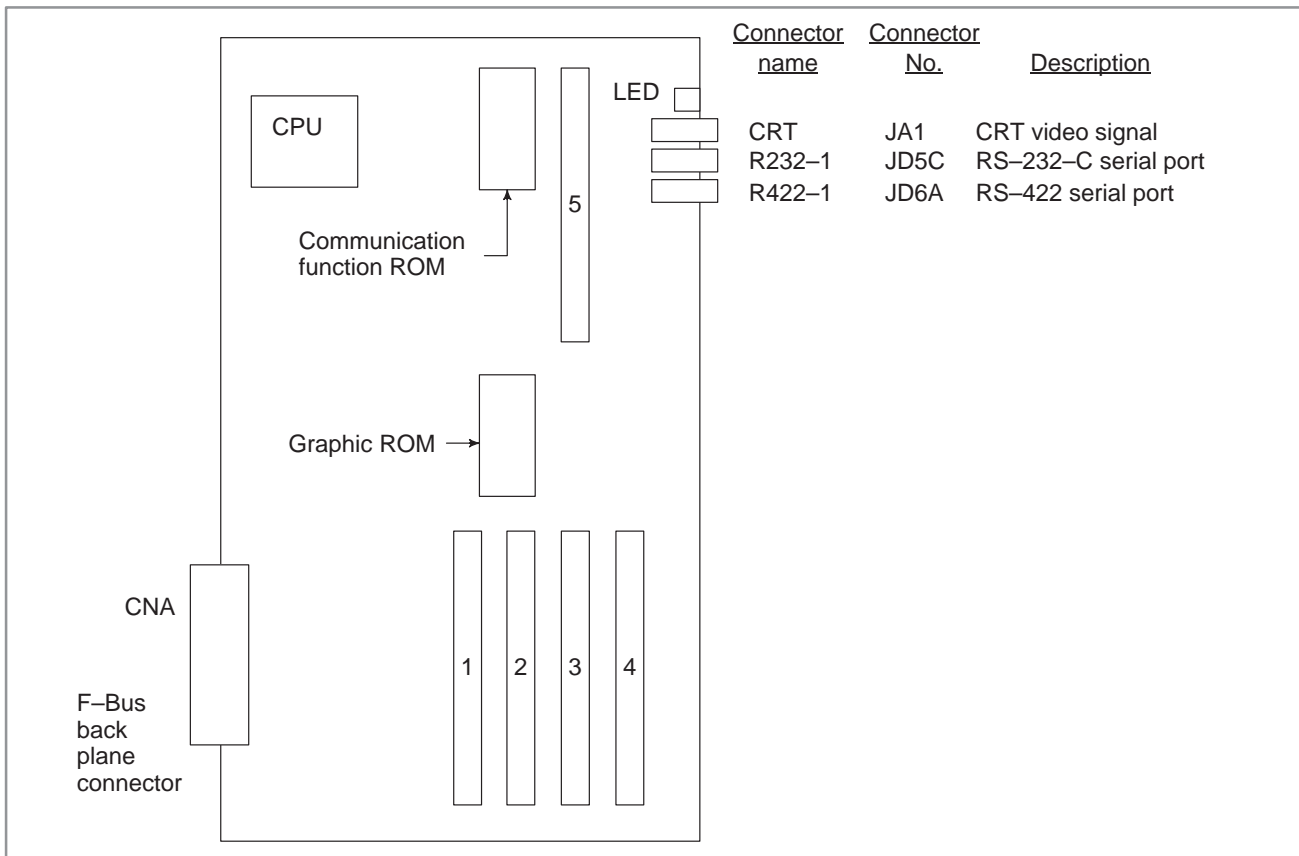

No.	Module name	Function outline
1	Graphic CPU module	Graphic display control CPU
2	Graphic engine module	Graphic display control circuit (No.2) Add in case of CAP II of FS15-TT.
3	Graphic engine module	Graphic display control circuit (No.1)
4	CRT control module	Character display control circuit for 9" CRT Character display control circuit for 10.4" LCD Character display control circuit for 14" CRT
5	Communication control module	Serial communication control, DMA control

(2) Block diagram

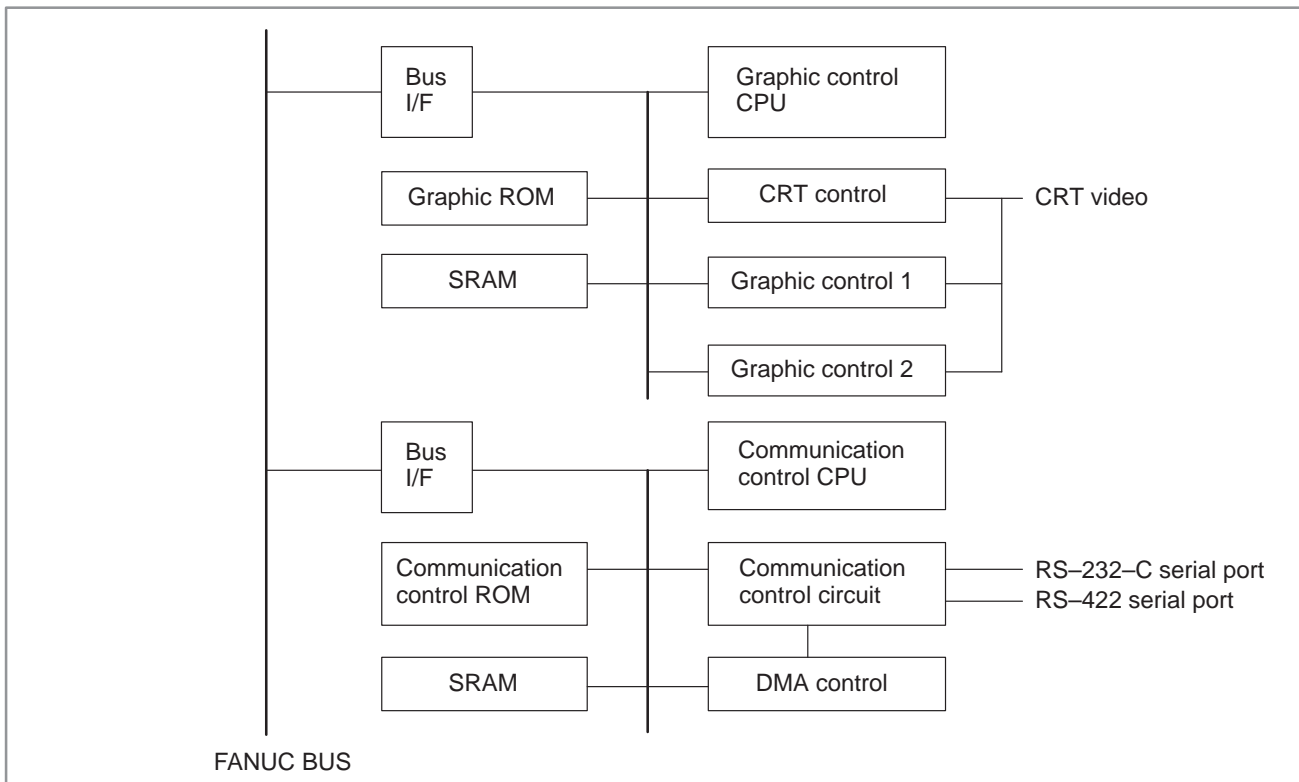

(3) Adjustment

No adjustment is needed.

(4) LED display

The STATUS LEDs in the front upper section of the option board are used for two independent functions as shown in the figure on the below.

□ : Off ■ : Lit ★☆ : Flashing ◆ : Don't care

★★ means both of LED are flashing at the same time.

★☆ means both of LED are flashing alternately.

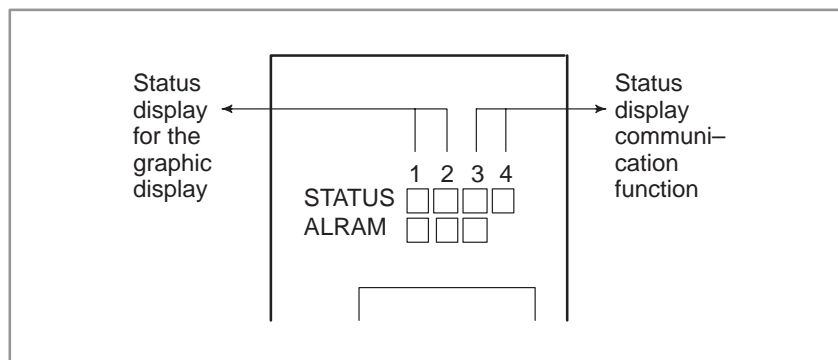

(a) LED display of graphic display function

1. LED display transition when the power is turned on

No.	LED display	NC status
1	STATUS ■■■■ ALARM ■□□	Startup status immediately after the power is turned on.
2	STATUS □■◆◆ ALARM □□□	Waiting for setting each processor of ID in the system.
3	STATUS ■□◆◆ ALARM □□□	Waiting for initialization of each processor in the system.
4	STATUS □□◆◆ ALARM □□□	The initialization of graphic display function is completed and on executing.

2. LED display when an error occurs

No.	LED display	NC status
1	STATUS ■□◆◆ ALARM ■□□	ROM parity error occurs. Change graphic ROM.
2	STATUS ■□◆◆ ALARM ■□□	RAM parity error occurs. Change option 1 board.
3	STATUS □★◆◆ ALARM ■□□	Command error occurs. Change option 1 board.
4	STATUS ★★◆◆ ALARM ■□□	NMI from other boards. Check LED display of other boards.
5	STATUS ★□◆◆ ALARM ■□□	Bus error (Wrong memory access) occurs. Change option 1 board.
6	STATUS ★☆◆◆ ALARM ■□□	Division error occurs. Change option 1 board.
7	STATUS ■★◆◆ ALARM ■□□	Incorrect interruption occurs. Change option 1 board.

(b) Communication function (Display of remote buffer)

1. LED display transition when the power is turned on

No.	LED display	NC status
1	STATUS ■■■■ ALARM ■□□	Startup status immediately after power is turned on or remote buffer CPU is not executing.
2	STATUS ◆◆□□ ALARM ◆□□	Initialization of remote buffer is beginning.
3	STATUS ◆◆■□ ALARM ◆□□	Initialization of remote buffer is completed and status of waiting for command from CNC.
4	STATUS ◆◆□■ ALARM ◆□□	Command is executed.
5	STATUS ◆◆■■ ALARM ◆□□	On closing (After closing, back to the status of No.3)

2. LED display when an error occurs

No.	LED display	NC status
1	STATUS ◆◆★□ ALARM ◆□□	ROM parity alarm occurred.
2	STATUS ◆◆□★ ALARM ◆□□	RAM error of test
3	STATUS ◆◆★☆ ALARM ◆□□	A fault occurred in the remote buffer. (BUS ERROR, illegal interruption etc....)
4	STATUS ◆◆★★ ALARM ◆□□	NMI from other boards
5	STATUS ◆◆◆◆ ALARM ◆□■	Parity alarm occurred on the work RAM of remote buffer.

2.5.20
OSI Ethernet Board
Configuration
(10 Base 2)

(1) Parts layout

Drawing number : A16B-2201-0571

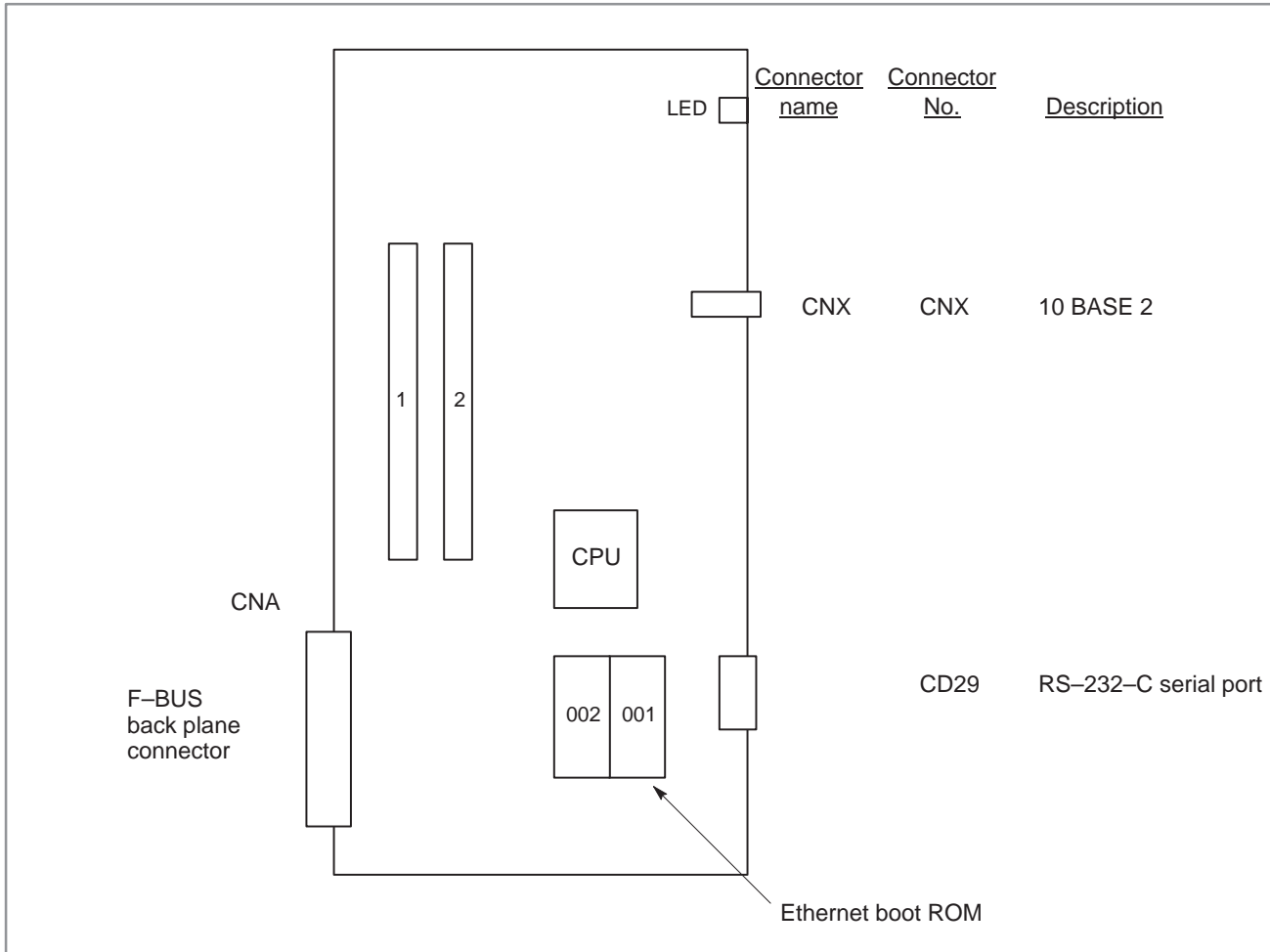

No.	Module name	Function outline
1	DRAM module	Work RAM
2	F-ROM module	System ROM for ethernet

NOTE

The OSI Ethernet board cannot be used with the Series 15MEK/MEL/TED/TEF/TEF-B-4.

(2)Block diagram

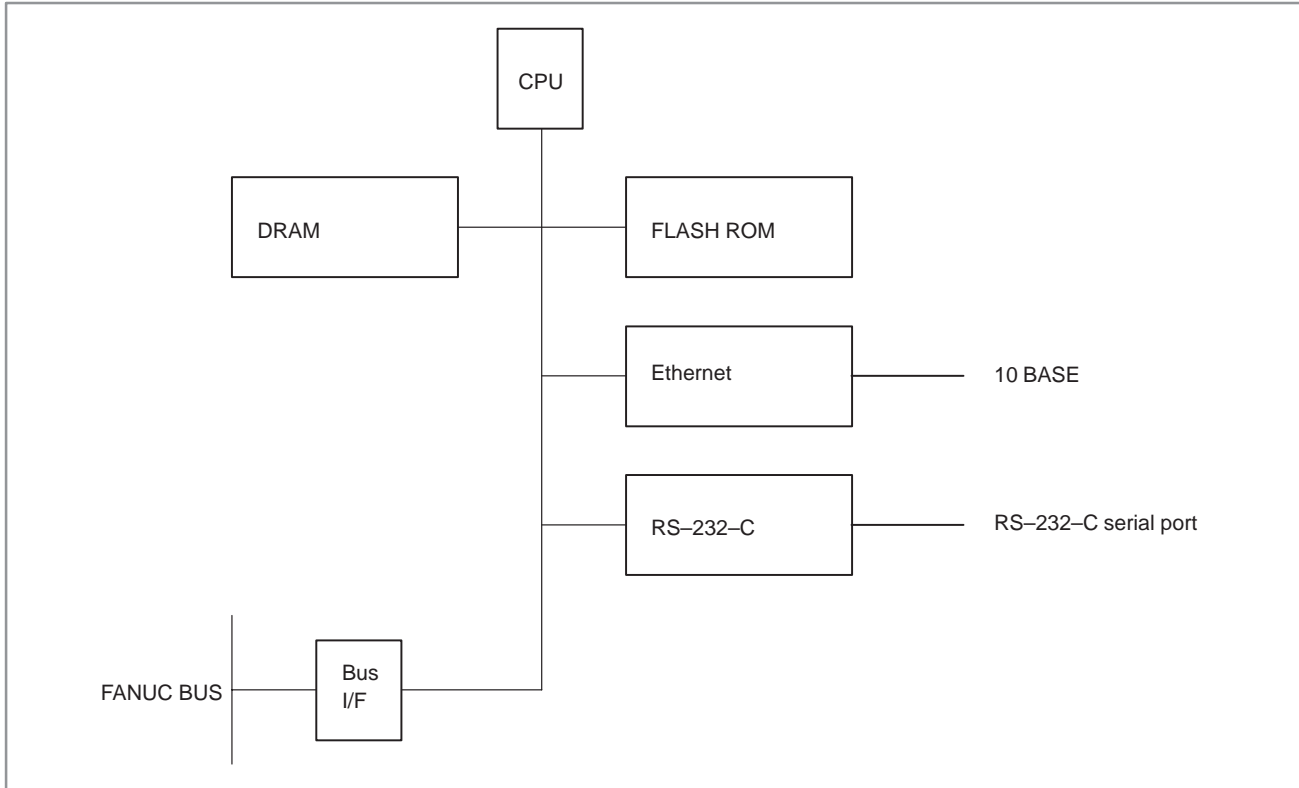

(3)Adjustment

No adjustment is needed.

(4)LED display

□ : Off ■ : Lit ★ : Flashing

STATUS LEDs are green. ALARM LEDs are red.

1. LED display transition when the power is turned on (STATUS LED)

No.	LED display	NC status
1	ALARM □□□□	Power-off
2	ALARM ■■■■	Initial state immediately after power-on
3	ALARM □□★★	During self-diagnosis
4	ALARM ■□□□	Normal state. The power on sequence is ended.

2. LED display when an error occurs (STATUS LED)

No.	LED display	NC status
1	ALARM □◇◇◇	An error occurred on the Ethernet board.
2	ALARM ■□□★	Connection to the network failed.

3. LED display when an error occurs (ALARM LED)

No.	LED display	NC status
1	ALARM ■□□	SYSFAIL state (occurred on the board)
2	ALARM □■□	Watchdog alarm
3	ALARM □□■	A parity error occurred in the DRAM area.

**2.5.21
OSI Ethernet Board
Configuration
(10 Base 5)**

(1) Parts layout

Drawing number : A16B-2201-0570

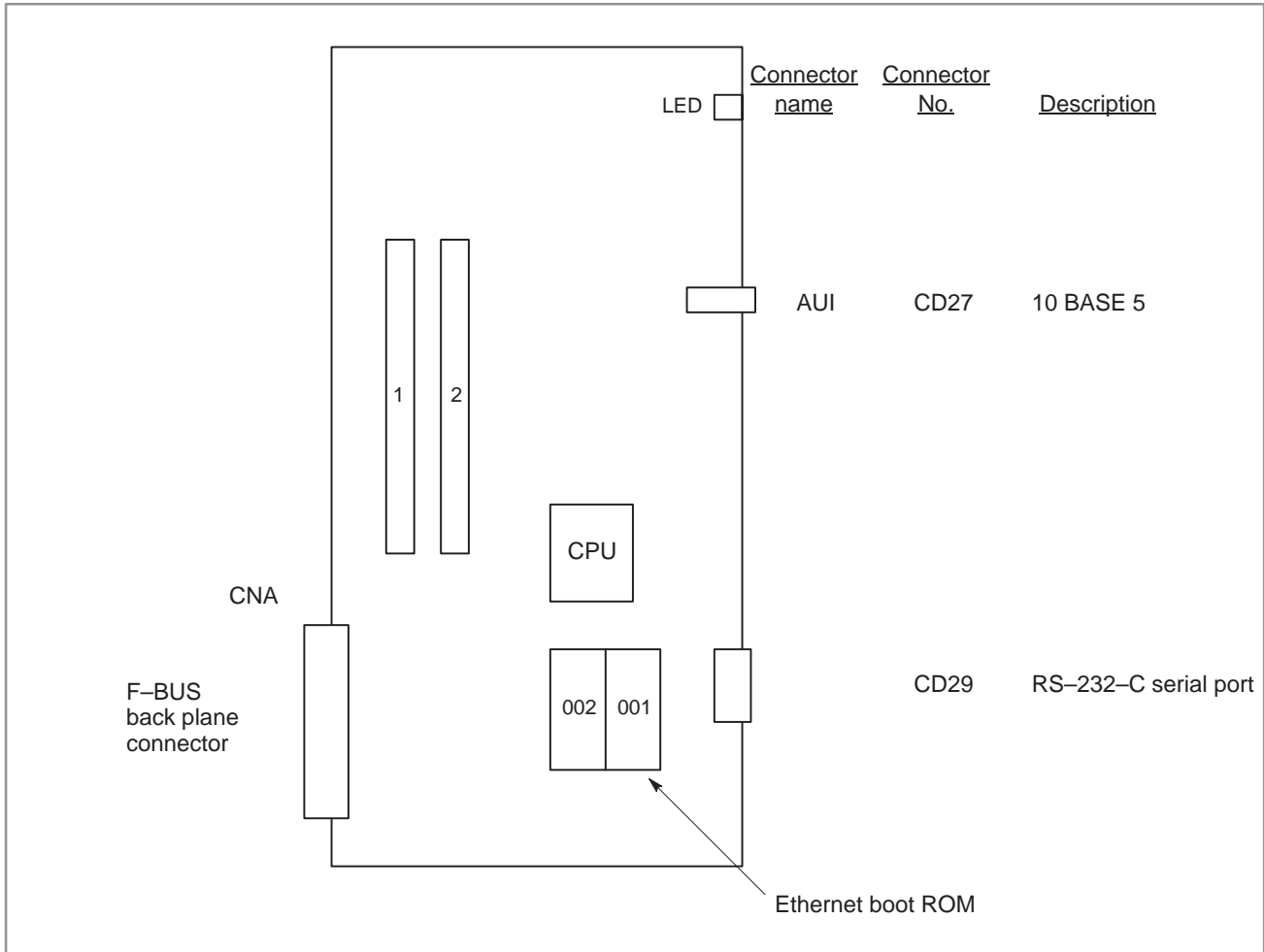

No.	Module name	Function outline
1	DRAM module	Work RAM
2	F-ROM module	System ROM for ethernet

NOTE

The OSI Ethernet board cannot be used with the Series 15MEK/MEL/TED/TEF/TEF-B-4.

(2) Block diagram

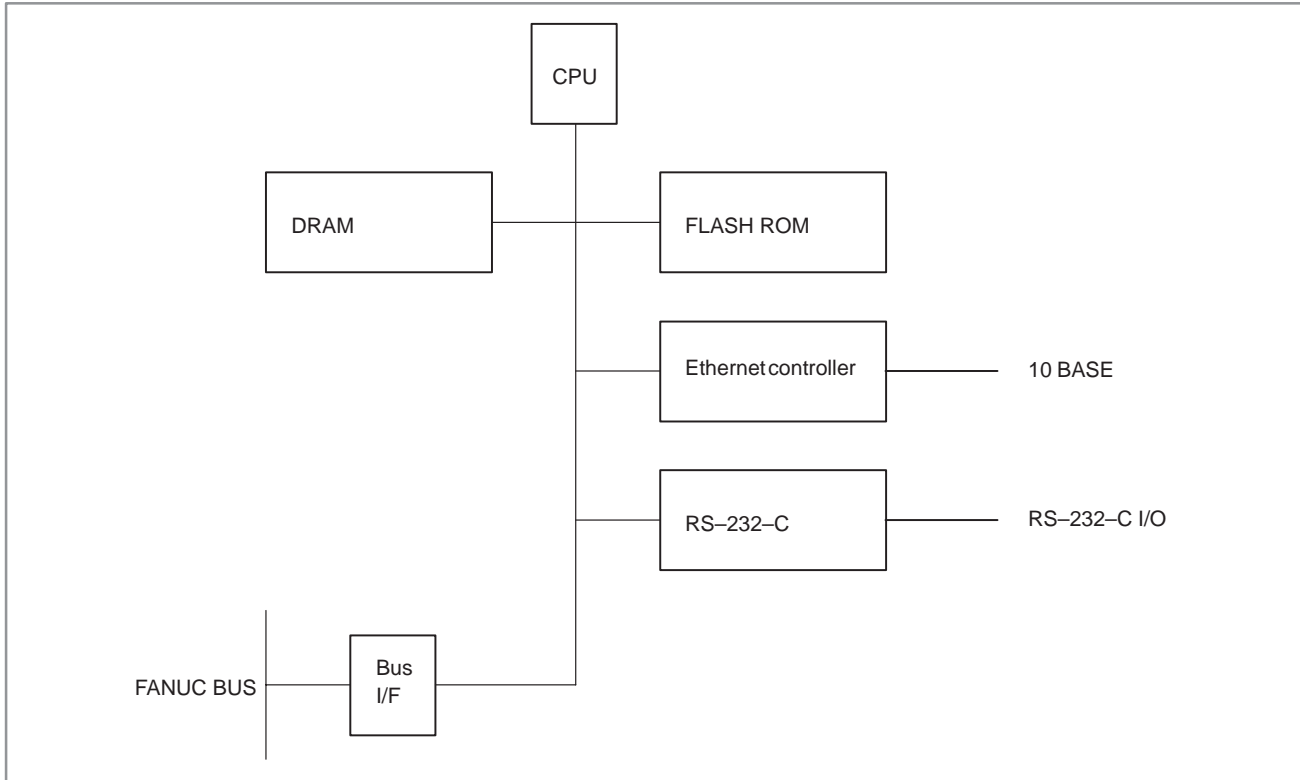

(3) Adjustment

No adjustment is needed.

(4) LED display

□ : Off ■ : Lit ★ : Flashing

STATUS LEDs are green. ALARM LEDs are red.

- LED display transition when the power is turned on (STATUS LED)

No.	LED display	NC status
1	ALARM □□□□	Power-off
2	ALARM ■■■■	Initial state immediately after power-on
3	ALARM □□★★	During self-diagnosis
4	ALARM ■□□□	Normal state. The power on sequence is ended.

- LED display when an error occurs (STATUS LED)

No.	LED display	NC status
1	ALARM □◇◇◇	An error occurred on the Ethernet board.
2	ALARM ■□□★	Connection to the network failed.

- LED display when an error occurs (ALARM LED)

No.	LED display	NC status
1	ALARM ■□□	SYSFAIL state (occurred on the board)
2	ALARM □■□	Watchdog alarm
3	ALARM □□■	A parity error occurred in the DRAM area.

2.5.22 Alarm LED Display (Red) in the Event of an Error

With the Series 15-B, if an error occurs on a PC board other than the main board or sub-board, the red LED on the main board or sub-board may light.

The tables below list the ALARM LED statuses when an error occurs on the main board or on a sub-board:

ALARM LED display when an error occurs
(when the main CPU is MAIN-A or MAIN-B)

Main board	Sub-board	Description
<input type="checkbox"/> <input type="checkbox"/> <input checked="" type="checkbox"/> SYSEMG.	<input type="checkbox"/> <input type="checkbox"/> <input checked="" type="checkbox"/> SYSEMG.	An NMI error occurred on the PMC, remote buffer, or a PC board other than the main board or sub-board on the F-bus. The power supply unit supplies a lower-than-normal voltage.
<input checked="" type="checkbox"/> <input checked="" type="checkbox"/> <input type="checkbox"/> SERVO ALARM	<input type="checkbox"/> <input checked="" type="checkbox"/> <input type="checkbox"/> SYSFAIL	An error occurred in the servo module on the main board. The software detected an error on a PC board on the F-bus.
<input type="checkbox"/> <input type="checkbox"/> <input checked="" type="checkbox"/> SYSEMG.	<input checked="" type="checkbox"/> <input checked="" type="checkbox"/> <input type="checkbox"/> SERVO ALARM	An error occurred in the servo module of the sub-board.

ALARM LED display when an error occurs
(when the main CPU is MAIN-C)

Main board	Sub-board	Description
<input type="checkbox"/> <input checked="" type="checkbox"/> <input type="checkbox"/> SYSFAIL	<input type="checkbox"/> <input checked="" type="checkbox"/> <input type="checkbox"/> SYSFAIL	The software detected an error on a PC board on the F-bus.
<input type="checkbox"/> <input type="checkbox"/> <input checked="" type="checkbox"/> SYSEMG.	<input type="checkbox"/> <input type="checkbox"/> <input checked="" type="checkbox"/> SYSEMG.	An NMI error occurred on the PMC, remote buffer, or a PC board other than main board or sub-board on the F-bus. The power supply unit supplies a lower-than-normal voltage.
<input checked="" type="checkbox"/> <input checked="" type="checkbox"/> <input type="checkbox"/> SERVO ALARM	<input type="checkbox"/> <input checked="" type="checkbox"/> <input type="checkbox"/> SYSFAIL	An error occurred in the servo module on the main board.
<input type="checkbox"/> <input checked="" type="checkbox"/> <input type="checkbox"/> SYSFAIL or <input type="checkbox"/> <input type="checkbox"/> <input checked="" type="checkbox"/> SYSEMG.	<input checked="" type="checkbox"/> <input checked="" type="checkbox"/> <input type="checkbox"/> SERVO ALARM	An error occurred in the servo module on the sub-board.

ALARM LED display when an error occurs
(when the main CPU is MAIN-A, -C)

Main board	Sub-board	Description
<input type="checkbox"/> <input checked="" type="checkbox"/> <input type="checkbox"/> SYSFAIL	<input type="checkbox"/> <input checked="" type="checkbox"/> <input type="checkbox"/> SYSFAIL	A software-detected error occurred on a PC board on the F-bus (including the F-bus on the additional shelf side).
<input type="checkbox"/> <input type="checkbox"/> <input checked="" type="checkbox"/> SYSEMG.	<input type="checkbox"/> <input type="checkbox"/> <input checked="" type="checkbox"/> SYSEMG.	On the main shelf side, an NMI error occurred on the PMC, remote buffer, or a PC board on the F-bus other than the main board and sub-board. The voltage being supplied from the power supply unit dropped.
<input checked="" type="checkbox"/> <input checked="" type="checkbox"/> <input type="checkbox"/> ADD SHELF SYSEMG.	<input type="checkbox"/> <input checked="" type="checkbox"/> <input type="checkbox"/> SYSFAIL	An NMI error occurred on a PC board on the additional shelf side. The voltage being supplied from the power supply on the additional shelf side dropped.

2.5.23

Alarm LED (Red) Display in the Event of an Error Occurring in the Connection Unit/Operator's Panel Connection Unit

- Alarm LED on the connection unit

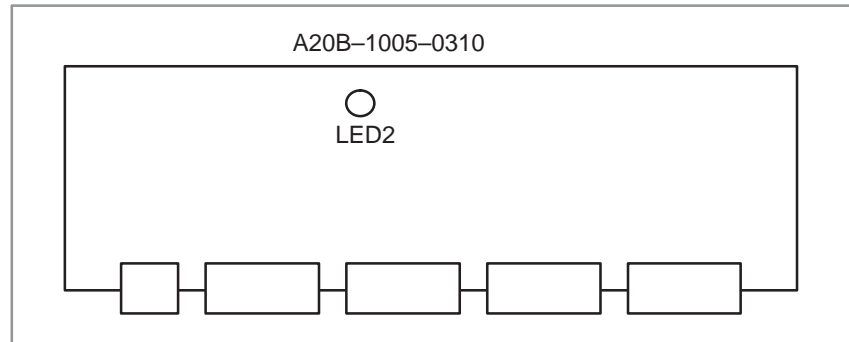

LED2 Off: Normal
On : Alarm state (Communication with the CNC is stopped.)

- Alarm LED on the operator's panel connection unit

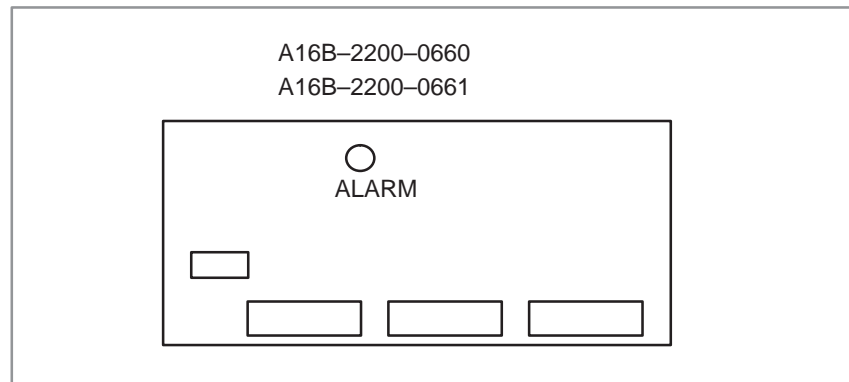

ALARM Off: Normal
On : Alarm state (Communication with the CNC is stopped.)

- **Alarm LED on the operator's panel connection unit (source output type)**

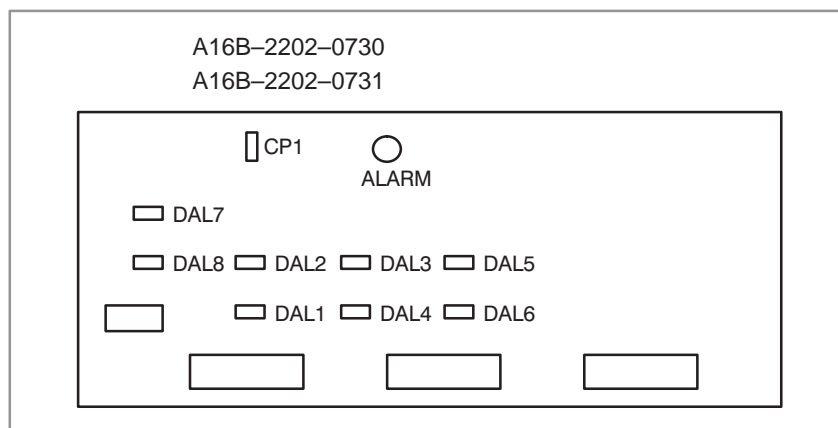

ALARM Off: Normal

On: Alarm state (Communication with the CNC is stopped.)

The operator's panel connection unit (source output type) has a function for issuing an alarm upon detecting an excessive current that may flow through the output driver element as a result of such as DO grounding.

If an alarm state is detected, the CNC is placed in the system alarm state, and the LED corresponding to the DO causing that alarm is turned on. (See the table below.)

By using setting pin CP1 on the board, the CNC can be prevented from being placed in the system alarm state due to an output driver alarm.

DAL1 Off: Normal

On: An error occurred in DO output Yq+0.0 to Yq+0.7.

DAL2 Off: Normal

On: An error occurred in DO output Yq+1.0 to Yq+1.7.

DAL3 Off: Normal

On: An error occurred in DO output Yq+2.0 to Yq+2.7.

DAL4 Off: Normal

On: An error occurred in DO output Yq+3.0 to Yq+3.7.

DAL5 Off: Normal

On: An error occurred in DO output Yq+4.0 to Yq+4.7.

DAL6 Off: Normal

On: An error occurred in DO output Yq+5.0 to Yq+5.7.

DAL7 Off: Normal

On: An error occurred in DO output Yq+6.0 to Yq+6.7.

DAL8 Off: Normal

On: An error occurred in DO output Yq+7.0 to Yq+7.7.

A system alarm caused by one of the above alarms is indicated as follows:

“SLC ERROR aa(bb)” Example: “SLC ERROR 03(01)”

(aa: XXXXXX11 Bits 0 and 1 are set to 1. The other bits are undefined.)

(bb: XXXXXX1 Bit 0 is set to 1. The other bits are undefined.)

Setting of setting pin CP1

Open: An alarm is reported to the CNC.

Connected: No alarm is reported to the CNC.

2.6 LIST OF THE PCBS AND UNITS

2.6.1 Control Unit Rack

Name		Drawing No.	Remarks		
Control unit rack	3-SLOT	A02B-0162-C001	FANUC name plate	Standard	Without sub. BUS
	4-SLOT	A02B-0162-C002			
	6-SLOT	A02B-0162-C003			
	8-SLOT	A02B-0162-C004		E Version	
		A02B-0240-C004			
	6-SLOT	A02B-0162-C008		Response to MMC-IV	
	8-SLOT	A02B-0162-C009			
	3-SLOT	A02B-0162-C011	GE Fanuc name plate	Standard	
	4-SLOT	A02B-0162-C012			
	6-SLOT	A02B-0162-C013			
	8-SLOT	A02B-0162-C014		E Version	
		A02B-0240-C014			
	6-SLOT	A02B-0162-C018		Response to MMC-IV	
	8-SLOT	A02B-0162-C019			
	4-SLOT	A02B-0162-C022	FANUC name plate	Standard	With Sub. BUS
	6-SLOT	A02B-0162-C023			
	8-SLOT	A02B-0162-C024			
	6-SLOT	A02B-0162-C028		Response to MMC-IV	
	8-SLOT	A02B-0162-C029			
	4-SLOT	A02B-0162-C032	GE Fanuc name plate		
	6-SLOT	A02B-0162-C033			
	8-SLOT	A02B-0162-C034			
	6-SLOT	A02B-0162-C038		Response to MMC-IV	
	8-SLOT	A02B-0162-C039			

2.6.2 Power Supply Unit

Name		Drawing No.	Remarks
Power supply unit	AI	A16B-1212-0471 A16B-1212-0901	Conventional type CE marking compatible type
	BI	A16B-1212-0531 A16B-1212-0871	Conventional type CE marking compatible type

2.6.3 Control Unit PCB

Name		Drawing No.	Remarks	Module ID
Main CPU board	Standard MAIN-B	A16B-2201-0320		
	High-speed MAIN-A	A16B-2201-0300		
	MAIN-C	A16B-3200-0060	Level up	
	MAIN-C	A16B-3200-0240	This board can not be used in Series 15MEK/MEL/TED/TEE/TEF.	
	High-speed MAX-MAIN-A	A16B-2201-0340	For multi axis control, synchronous control, and malfunction control	
	MAX-MAIN-C	A16B-2202-0640	For multi axis control, synchronous control, and malfunction control	
PMC/ Conversational board	Without conversational CPU for PMC-NA	A16B-2201-0371 A16B-2201-0391		77
	Without conversational CPU for PMC-NB	A16B-2201-0381 A16B-2201-0811		6B
	Without conversational CPU for PMC-NB/NB2	A16B-2201-0851		9D
	With conversational CPU for PMC-NA	A16B-2201-0390		77/6D
	With conversational CPU for PMC-NB	A16B-2201-0810		7B/6D
	With conversational CPU for PMC-NB/NB2	A16B-2201-0850		9D/6D
Additional axis board		A16B-2201-0311		63
Axis CPU board		A16B-2201-0360		7A
Buffer board		A16B-2201-0351		68
Sub CPU board	Standard MAX SUB-B	A16B-2201-0331	For multi axis control, synchronous Control, and malfunction control	73
	High-speed SUB-A	A16B-2201-0310		63
	SUB-C	A16B-2202-0571		A1

Name		Drawing No.	Remarks		Module ID
Option 1 board	Graphic + Remote buffer	A16B-2200-0910	Increase of graphic CPU RAM	For 10"LCD, 9"graphic, or 14"CRT (digital)	45/3F
	Graphic + DNC1	A16B-2200-0911			45/3F
	Graphic	A16B-2200-0912			45
	Graphic	A16B-2200-0917	Graphic CPU RAM (standard)		45
	Graphic + Remote buffer	A16B-2200-0915			45/3F
	Graphic + Remote buffer	A16B-2200-0918	Increase of graphic CPU RAM		For 9.5"LCD, 8.4"LCD, MMC-IV, or 14"CRT (analog)
	Graphic + DNC1	A16B-2200-0916		45/3F	
	Graphic	A16B-2200-0919		45	
	Remote buffer	A16B-2200-0913			3F
	DNC1	A16B-2200-0914			3F
RISC board		A16B-2201-0710			7F
		A16B-3200-0150	This board can not be used in Series 15MEK/MEL/TED/TEE/TEF.		AF
ROM cassette adapter		A20B-2000-0760			74
OSI ethernet board		A16B-2201-0570	10 BASE 5 This board can not be used in Series 15MEK/MEL/TED/TEE/TEF.		6F
		A16B-2201-0571	10 BASE 5 This board can not be used in Series 15MEK/MEL/TED/TEE/TEF.		6F

2.6.4 Back Panel PCB

Name		Drawing No.	Remarks
Back plane	3-SLOT	A20B-2000-0900	Standard
	4-SLOT	A20B-2000-0710	
	6-SLOT	A20B-2000-0720	
	8-SLOT	A20B-2000-0730	
	8-SLOT	A20B-2002-0430	for Series 15MEK/MEL/TED/TEE/TEF-B-4
	6-SLOT	A20B-2001-0651	Response to MMC-IV
	8-SLOT	A20B-2001-0661	
	Sub bus	A20B-1005-0270	

2.6.5 Module (For Main CPU Board)

Name		Drawing No.	Remarks
Spindle control	Serial spindle + High-speed skip	A20B-2900-0672	
	Analog spindle + High-speed skip	A20B-2900-0770	
Peripheral module		A20B-2900-0660	
FLASH ROM	8MB	A20B-2902-0375*	Note that, for those modules marked with *, the corresponding software is required.
	6MB	A20B-2900-0810	
	4MB	A20B-2900-0811	
	4MB	A20B-2902-0374*	
	2MB	A20B-2900-0812	
DRAM module	4MB	A20B-2900-0651	For MAIN-C
	2MB	A20B-2900-0800	
	6MB	A20B-2901-0940	
	4MB	A20B-2901-0941	
	2MB	A20B-2901-0942	
High-speed SRAM module		A20B-2900-0641	
SRAM module	2MB	A20B-2900-0682	
	1MB	A20B-2900-0680	
	512KB	A20B-2900-0681	
	256KB	A20B-2900-0700	
	128KB	A20B-2900-0701	
	64KB	A20B-2900-0711	
Servo control module		A20B-2901-0340	Used for servo software series 9060 and 9061 (no restriction on the edition)
		A20B-2902-0400	Used for servo software series 9060/edition R or later. Used for servo software series 9061/edition B or later.
		A20B-2902-0180	Used for servo software series 9070
		A20B-2902-0420	Used for servo software series 9070 and 9080
Servo interface module		A20B-2900-0830 A20B-2901-0360 A20B-2902-0440	
CRT control module		A20B-2900-0691	9" CRT control
		A20B-2902-0520	Used for an intelligent terminal and graphic function built-in 10.4" LCD

2.6.6 Module (For PMC/ Conversational Board)

Name		Drawing No.	Remarks
PMC CPU	PMC-NA	A20B-2900-0780	
	PMC-NB	A20B-2901-0581	
PMC engine	PMC-NA	A20B-2900-0790	
	PMC-NB	A20B-2901-0660	
PMC control module	PMC-NB	A20B-2901-0960	
	PMC-NB2	A20B-2902-0250	
DRAM module	2MB	A20B-2900-0653	
	512KB	A20B-2900-0803	
	1M/512K	A20B-2902-0192	Only for PMC-NB/NB2
	512K/512K	A20B-9202-0193	
	-/512K	A20B-2902-0194	
SRAM module	1.25MB	A20B-2901-0400	Only for PMC-NB
	512KB	A20B-2901-0402	
Conversational CPU module		A20B-2901-0390	
EPROM module	1MB	A20B-2900-0290	
	768KB	A20B-2900-0291	
	512KB	A20B-2900-0292	
DRAM module	1MB	A20B-2900-0550	
	512KB	A20B-2900-0551	
	128KB	A20B-2900-0555	
SRAM module	512KB	A20B-2900-0541	
SRAM/DRAM module	512K/512K	A20B-2901-0413	Only for PMC-NB/NB2

2.6.7 Module (For Sub CPU Board, Additional Axis Board, or Axis CPU Board)

Name		Drawing No.	Remarks
Spindle control module	Analog spindle + High-speed skip	A20B-2900-0770	
	Serial spindle + High-speed skip	A20B-2900-0672	
Analog input & serial communication module		A20B-2900-0721	Serial communication is each one channel of RS-422 or RS-232C
Servo control module		A20B-2901-0340	Used for servo software series 9060 and 9061 (no restriction on the edition)
		A20B-2902-0400	Used for servo software series 9060/edition R or later. Used for servo software series 9061/edition B or later.
		A20B-2902-0180	Used for servo software series 9070
Servo interface module		A20B-2901-0360 A20B-2900-0830	
DRAM module	2MB	A20B-2900-0800	
	1MB	A20B-2900-0802	
	2MB	A20B-2901-0942	For SUB-C
High-speed SRAM module		A20B-2900-0641	
SRAM module	512KB	A20B-2900-0681	
	256KB	A20B-2900-0700	
Error motion check module		A20B-2900-0830	

2.6.8 Module (For RISC Board)

Name		Drawing No.	Remarks
SRAM module	512KB	A20B-2900-0541	
ROM module	512KB	A20B-2900-0292	

2.6.9 Module (Option 1 Board)

Name		Drawing No.	Remarks
CRT Control module	14" CRT	A20B-2901-0370	Standard
		A20B-2902-0278	
	10" LCD 10" PDP	A20B-2901-0372	
	9.5" LCD	A20B-2902-0272	
	9" CRT 9" PDP	A20B-2901-0371	
	14" CRT	A20B-2901-0373	MMC-III
	10" LCD	A20B-2901-0375	
	MMC-IV	A20B-2902-0275	MMC-IV
Communication control module		A20B-2900-0361	
Graphic control module		A20B-2900-0311	
Graphic CPU module		A20B-2900-0350	

NOTE

When a graphic function built-in 10.4" LCD is used, the graphic function of the option 1 board is not used.

2.6.10 Module (OSI Ethernet Board)

Name	Drawing No.	Remarks
DRAM module	A20B-2901-0254	
F-ROM module	A20B-2900-0481	

2.6.11 Display Unit

Name		Drawing No.	Remarks	
9" CRT/MDI	Monochrome, vertical type	A02B-0162-C041		
		A02B-0162-C044		
		A02B-0163-C244	CE marking, English MDI	
		A02B-0163-C444	CE marking, Symbolic MDI	
	Monochrome, horizontal type	A02B-0162-C042		
		A02B-0162-C045		
		A02B-0163-C245	CE marking, English MDI	
		A02B-0163-C445	CE marking, Symbolic MDI	
	Color, vertical type	A02B-0162-C051		
		A02B-0162-C054		
Color, horizontal type	A02B-0162-C052			
	A02B-0162-C055			
9" small CRT/MDI	Mono- chrome	M	A02B-0162-C101	
			A02B-0163-C301	CE marking, English MDI
	T		A02B-0162-C102	
			A02B-0163-C302	CE marking, English MDI
	Color	M	A02B-0162-C103	
		T	A02B-0162-C104	
9" PDP/MDI	Monochrome, horizontal type	A02B-0162-C062		
		A02B-0162-C065		
		A02B-0163-C265	CE marking, English MDI	
		A02B-0163-C465	CE marking, Symbolic MDI	
9" small PDP/MDI	Mono- chrome	M	A02B-0162-C105	
			A02B-0163-C305	CE marking, English MDI
	T		A02B-0162-C106	
			A02B-0163-C306	CE marking, English MDI

Name		Drawing No.	Remarks
9.5"LCD/ MDI	Color, vertical type	A02B-0162-C131	
		A02B-0163-C331	CE marking, English MDI
		A02B-0162-C141	MMC-IV
		A02B-0163-C341	MMC-IV, CE marking, English MDI
		A02B-0162-C133	15-TFB, 15-TTFB, 15TEF
		A02B-0163-C333	15-TFB, 15-TTFB, 15TEF, CE marking, English MDI
	Color, horizontal type	A02B-0162-C132	
		A02B-0163-C332	CE marking, English MDI
		A02B-0162-C142	MMC-IV
		A02B-0163-C342	MMC-IV, CE marking, English MDI
		A02B-0162-C132	15-TFB, 15-TTFB, 15TEF
		A02B-0163-C332	15-TFB, 15-TTFB, 15TEF, CE marking, English MDI
10"LCD/ MDI	Color, vertical type	A02B-0162-C071	
		A02B-0162-C073	15-TFB, 15-TTFB, 15TEF
	Color, horizontal type	A02B-0162-C072	
		A02B-0162-C074	15-TFB, 15-TTFB, 15TEF
10.4"LCD/ MDI	Color, vertical type	A02B-0163-C371	CE marking, graphic function built-in
		A02B-0163-C571	CE marking, graphic function built-in Symbolic MDI
		A02B-0163-C381	CE marking, for MMC-IV
		A02B-0163-C581	CE marking, for MMC-IV Symbolic MDI

Name		Drawing No.	Remarks
10.4"LCD/ MDI	Color, horizontal type	A02B-0163-C372	CE marking, graphic function built-in
		A02B-0163-C572	CE marking, graphic function built-in Symbolic MDI
		A02B-0163-C382	CE marking, for MMC-IV
		A02B-0163-C582	CE marking, for MMC-IV Symbolic MDI
10"PDP/ MDI	Monochrome, vertical type	A02B-0162-C081	
	Monochrome, horizontal type	A02B-0162-C082	
14"CRT/ MDI	Color, vertical type	A02B-0162-C091	
		A02B-0162-C093	15-TFB, 15-TTFB, 15TEF
		A02B-0162-C121	MMC-IV
		A02B-0163-C321	CE marking, English MDI*
		A02B-0163-C323	CE marking, English MDI, 15-TFB, 15-TTFB, 15TEF
		A02B-0163-C523	CE marking, Symbolic MDI, 15-TFB, 15-TTFB, 15TEF
	Color, horizontal type	A02B-0162-C092	
		A02B-0162-C094	15-TFB, 15-TTFB, 15TEF
		A02B-0162-C122	MMC-IV
		A02B-0163-C322	CE marking, English MDI*
		A02B-0163-C324	CE marking, English MDI, 15-TFB, 15-TTFB, 15TEF
		A02B-0163-C522	CE marking, Symbolic MDI
Separate type CRT	Monochrome	A02B-0162-C046	
	Color	A02B-0162-C056	
Separate type PDP	Monochrome	A02B-0162-C066	
		A02B-0163-C268	CE marking

Name		Drawing No.	Remarks
Separate type 10.4"LCD unit	Color	A02B-0222-C150	CE marking, graphic function built-in
Separate type 9.5"LCD unit	Monochrome	A02B-0222-C110	CE marking

* : Shared by 15-MB, 15-MFB, 15-TB, 15-TTB, 15MEL 15TEE and MMC-IV

2.6.12 External Control Unit (Except I/O Unit)

Name		Drawing No.	Remarks
Separate type MDI unit		A02B-0162-C111	
		A02B-0162-C112	
		A02B-0163-C312	CE marking, English MDI
		A02B-0163-C313	CE marking, Symbolic MDI
		A02B-0163-C316	CE marking, for separate type LCD, vertical type, English MDI*
		A02B-0163-C317	CE marking, for separate type LCD, horizontal type, English MDI*
		A02B-0163-C318	CE marking, for separate type LCD, vertical type, English MDI*
		A02B-0163-C319	CE marking, for separate type LCD, horizontal type, English MDI*
Connection unit 1		A20B-1005-0310	DI/DO 96/64
Connection unit 2		A20B-1003-0200	DI/DO 96/64
Operator's panel con- nection unit	DI/DO 64/32	A16B-2200-0661	Sink type
		A16B-2202-0731	Source type
	DI/DO 96/64	A16B-2200-0660	Sink type
		A16B-2202-0730	Source type
Optical I/O Link adaptor		A13B-0154-B001	
Input unit for multiple axis system		A14B-0076-B402	

I/O Unit-MODEL A

Name		Drawing No.	Remarks					
Basic unit	ABU10A	A03B-0807-J001	It's possible to mount up to 10 modules.					
	ABU10B	A03B-0807-J004						
Basic unit	ABU05A	A03B-0807-J002	It's possible to mount up to 5 modules.					
	ABU05B	A03B-0807-J003						
Interface module	AIF01A	A03B-0807-J011	For slave					
	AIF01B	A03B-0807-J012						
	AIF02C	A03B-0807-J013						
Digital input module		Drawing No.	Type	Point	Voltage	Polarity	Response	Connection
*1.When input is Lo level, it will be considered to turn on. (0V common)	AID32A1	A03B-0807-J101	Non-insulation type DC input	32	24VDC	Both	20ms	Connector A
	AID32B1	A03B-0807-J102		32	24VDC	Both	2ms	Connector A
	AID32H1	A03B-0807-J111		32	24VDC	Both	2ms: 8 20ms: 8	Connector A
*2.When Input is Hi level, it will be considered to turn on. (24V common)	AID16C	A03B-0807-J103	Insulation type DC input	16	24VDC	*1 NEG	20ms	Terminal block
	AID16D	A03B-0807-J104		16	24VDC	*2 POS	20ms	Terminal block
	AID16K	A03B-0807-J113		16	24VDC	*1 NEG	2ms	Terminal block
	AID16L	A03B-0807-J114		16	24VDC	*2 POS	2ms	Terminal block
	AID32E1	A03B-0807-J105	Insulation type DC input	32	24VDC	Both	20ms	Connector A
	AID32E2	A03B-0807-J110		32	24VDC	Both	20ms	Connector B
	AID32F1	A03B-0807-J106		32	24VDC	Both	2ms	Connector A
	AID32F2	A03B-0807-J109		32	24VDC	Both	2ms	Connector B
	AID16G	A03B-0807-J107	AC input	16	100 -115VAC	ON 30ms OFF 45ms	Terminal block	

I/O Unit-MODEL A

Name	Drawing No.	Remarks						
Digital output module	Drawing No.	Type	point	Voltage	Porarity	Responce	Connection	
*3.When turning on, output becomes Lo level. (0V common) *4.When turning on output becomes Lo level. (24V common)	AOD32A1	A03B-0807-J162	Non - inslation type DC output	32	5 -24VDC	*3 NEG	0.3A	Connection A
	AOD08C	A03B-0807-J151	Inslation type DC output	8	12 -24VDC	*3 NEG	2A	Terminal block
	AOD08D	A03B-0807-J152		8		*4 POS	2A	Terminal block
	AOD16C	A03B-0807-J153		16		*3 NEG	0.5A	Terminal block
	AOD16D	A03B-0807-J154		16		*4 POS	0.5A	Terminal block
	AOD32C1	A03B-0807-J155		32		*3 NEG	0.3A	Connector A
	AOD32D1	A03B-0807-J156		32		*4 POS	0.3A	Connector A
	AOD32D2	A03B-0807-J167		32		*4 POS	0.3A	Connector B
	AOA05E	A03B-0807-J157		AC output		5	100 -230VAC	
	AOA08E	A03B-0807-J158	8			1A		Terminal block
	AOA12F	A03B-0807-J159	12		100 -115VAC		0.5A	Terminal block
	AOR08G	A03B-0807-J160	Relay output	8	250VAC /30VDC		4A	Terminal block
	AOR16G	A03B-0807-J161		16			2A	Terminal block
	AOR16H2	A03B-0807-J165		16	30VDC		2A	Connector B
	Analog input module	AAD04A	A03B-0807-J051	Analog input 4 channels				
Analog output module	ADA02A	A03B-0807-J052	Analog output 2 channels					
High-speed counter module	ACT01A	A03B-0807-J052	Pulse input 1 channel					

2.7 HOW TO REPLACE THE MODULES

2.7.1 Removing

- (1) Pull the latches of the module socket outwards. (Fig.(a))
- (2) Pull out the module upward. (Fig.(b))

2.7.2 Insertion

Procedure for insetion of the module

- (1) Insert the new module board diagonally with B-SIDE outward (Fig.b)
- (2) While pushing on the upper edge of the module board, raise it until it is locked (Fig.(c)).

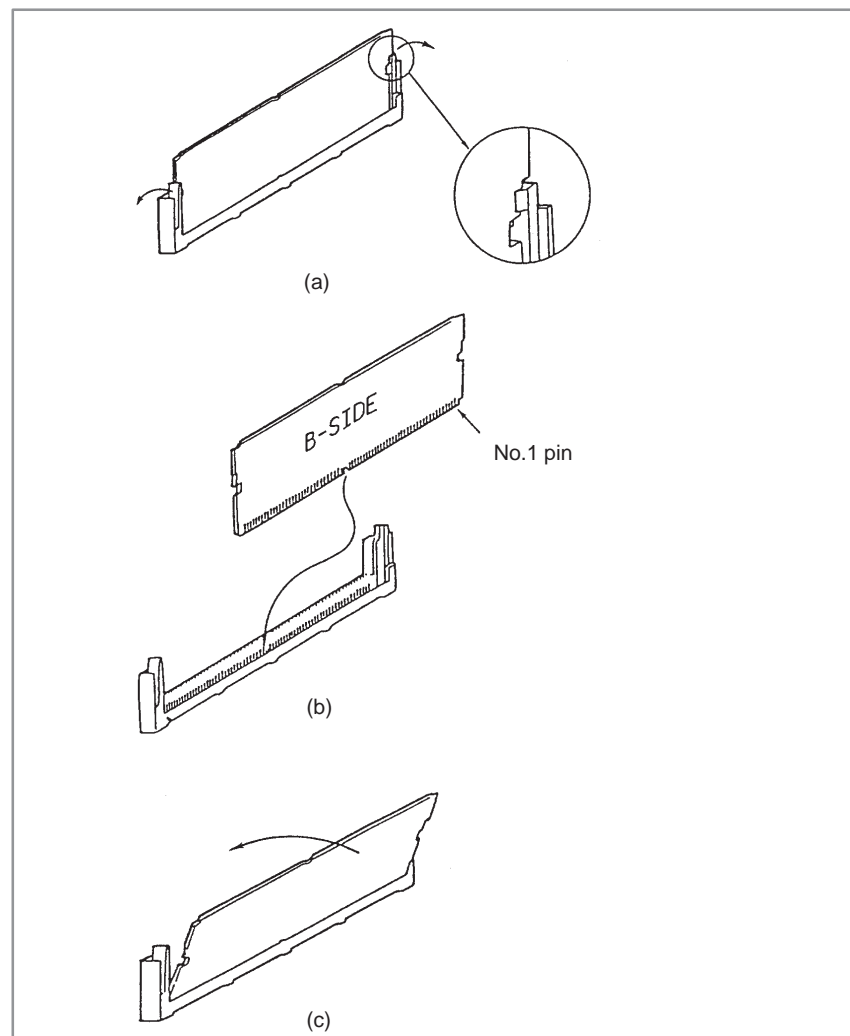

2.8 HOW TO REPLACE THE BATTERIES

2.8.1 Replace the Battery for Memory Back Up

- (1) Use the following lithium batteries:
When the power supply unit is A02B-0162-H101 or -H102:
Ordering drawing number A98L-0031-0007
When the power supply unit is A02B-0162-H107 or -H108:
Ordering drawing number A98L-0031-0012
- (2) Turn on the 15-B
- (3) Remove the battery case from the front panel of the power supply unit.
The case can be removed easily by holding the top and bottom of it and pulling.

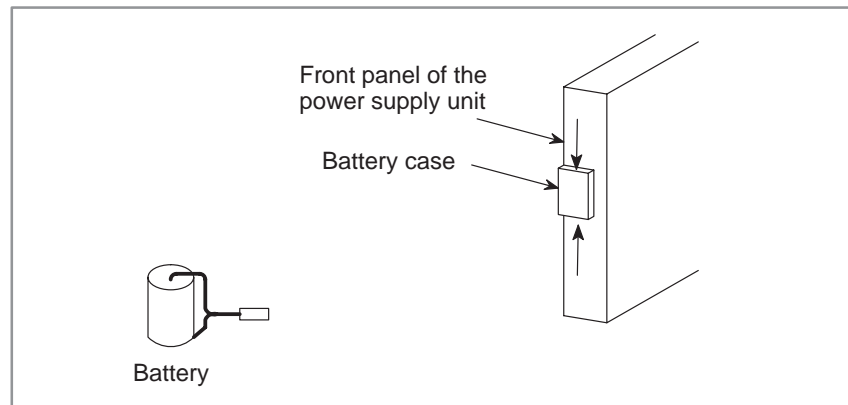

Fig. 2.8.1 (a) Replacing the battery (1)

- (4) Remove the connector from the battery.

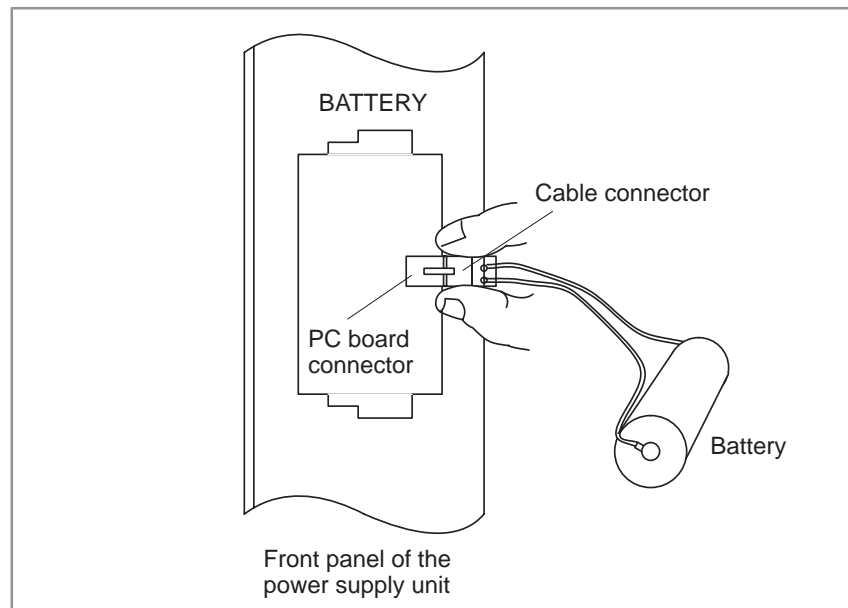

Fig. 2.8.1 (b) Replacing the battery (2)

- (5) Replace the battery and reconnect the connector.
- (6) Install the battery case.
- (7) Turn off the Series 15-B

2.8.2 Replacing Batteries for Separate Absolute Pulse Coder

Procedure for replacing the batteries for absolute pulse coder

- 1 Prepare 4 commercially available dry cell batteries
- 2 Turn on CNC power.
If the batteries are replaced with the power off, absolute position of the machine is lost.
- 3 Loosen the screws of battery case lid and remove the lid.
Consult with the MTB's manual for where the battery case is installed.
- 4 Replace the batteries in the case.
Take care to place the batteries facing in the correct direction. (Insert the batteries as shown in the diagram with 2 facing one way and 2 the other.)

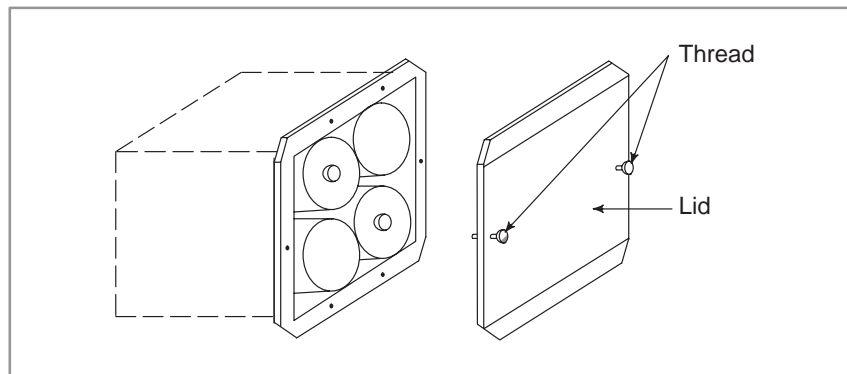

- 5 Having exchanged the batteries put the lid back on.
- 6 Turn off the power once, then turn it to on.
- 7 A battery alarm may be generated, but execute power off and on.
- 8 Procedure completes.

2.9 HOW TO REPLACE FAN MOTOR

Fan ordering information

	Ordering code	Number of units required
For 2-slot rack	A90L-0001-0378	For 1-slot rack
For 1-slot rack	A90L-0001-0385#A	For 2-slot rack

Procedure for replacing the fan motor

- 1 Remove the control section printed circuit board underneath the fan to be replaced.
- 2 There is a backplane inside the slot. The fan motor cable is connected to the backplane. Grasp the left and right side of the cable connector attached to the backplane and remove it.
- 3 Open the upper lid of the control section rack. Insert a philips head screwdriver into the hole at the center front of the lid. The latch holding the cover in place can be released by prying with the screwdriver in the direction shown in (3) of following figure.
- 4 Open the lid sufficiently and remove the fan motor. Since the fan itself is not screwed into the rack, it can be easily removed.
- 5 Install the new fan motor. Guide the fan motor cable through the hole and into the rack.
- 6 Close the lid until the latch locks.
- 7 Attach the fan motor cable to the connector on the back plane. At this time, affix the middle portion of the cable to the hooks at the back of the rack.
- 8 Insert the removed control section printed circuit board.

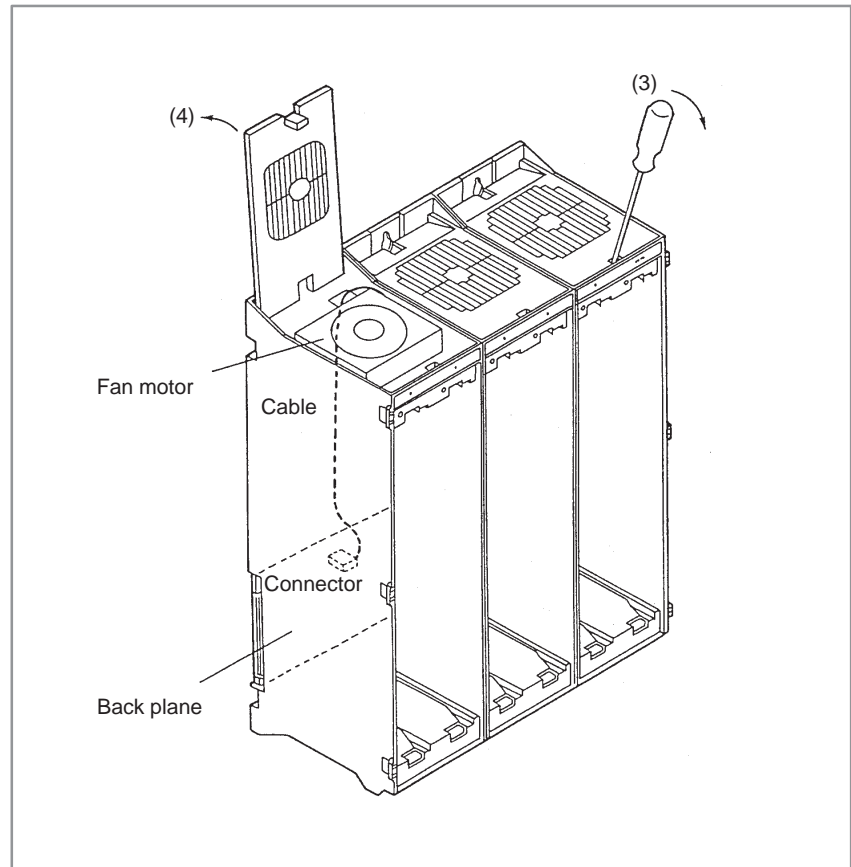

Fig. 2.9 Fan motor replacement

2.10 FUSE REPLACEMENT IN POWER SUPPLY UNIT

When a fuse blows in the power supply unit of the CNC, find and correct the cause of the failure and replace the fuse.

Each fuse has a small window in which a white mark appears when the fuse has blown.

Fig. 1 shows the fuse mounting diagram, and table 1 shows the fuse lists. (For the fuse specifications, see Section 2.5.1.)

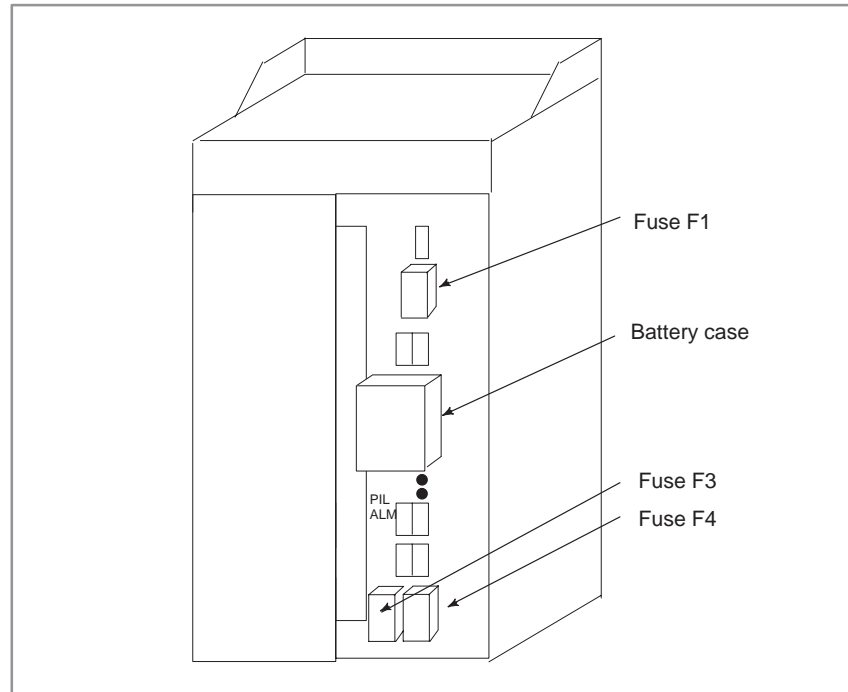

Fig. 2.10 (a) Mounting positions of fuses in the power supply unit (Power supply unit of CE marking compatible type)

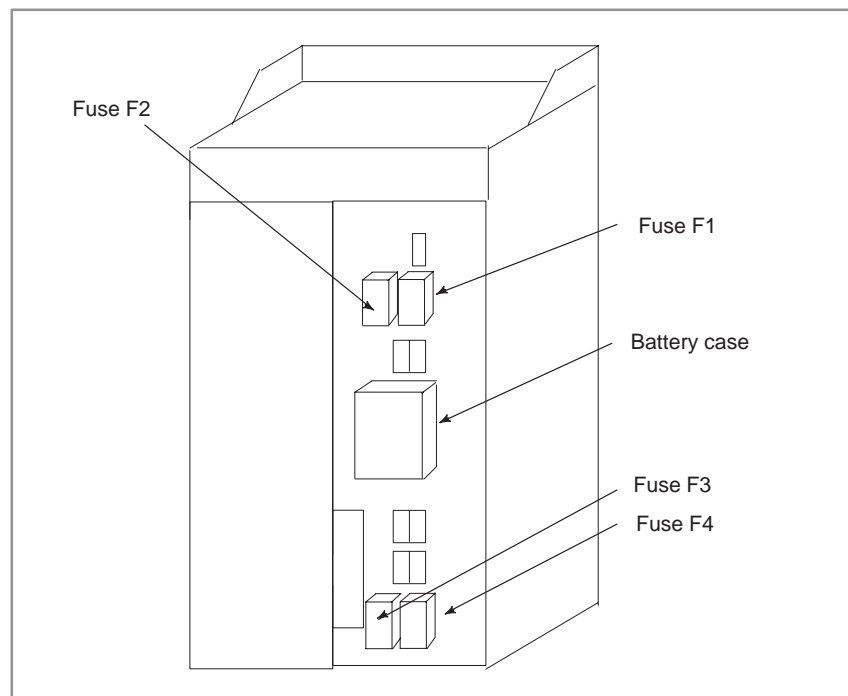

Fig. 2.10 (b) Mounting positions of fuses in the power supply unit (Power supply unit of conventional type)

2.11 MAINTENANCE OF HEAT PIPE TYPE HEAT EXCHANGER

It is necessary to regularly clean the heat transformer, because the heat transformation ability will be reduced by the accumulation of dust. The frequency of the cleaning needed differs according to the installation environment and therefore should be determined by your own judgment according to the degree of dirt.

Air filter cleaning and replacement method

- 1 When cleaning and replacing the filter, be sure to cut off the fan's electric power source.
- 2 Detach the filter cover and take out the filter inside.

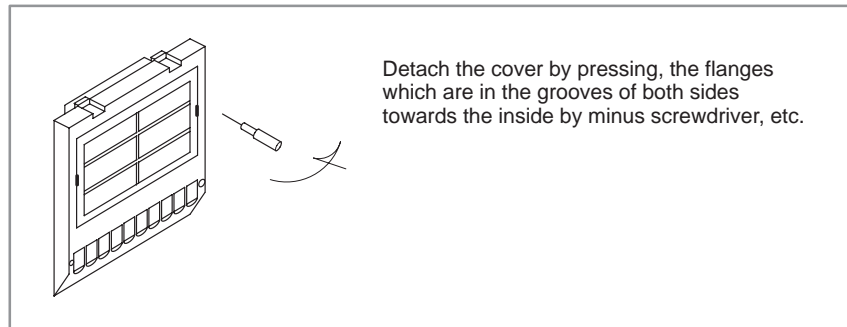

- 3 Protect the filter from silting due to dust by blowing air on both sides.

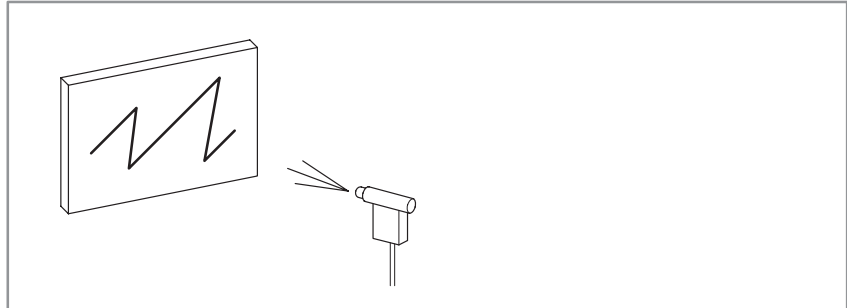

- 4 When dirt is conspicuous, press wash with a neutral detergent, rinse with fresh water, and the washing, allow to dry naturally. When replacing with the same product.
- 5 Insert the filter in the cover, align the flange in the groove, and install by pressing. Confirm that the cover will not come loose even if it is pulled.

Cleaning heat exchanger

- 1 When cleaning, be sure to cut off the fan power source.
- 2 Take out the external fan unit from the heat exchanger main unit.

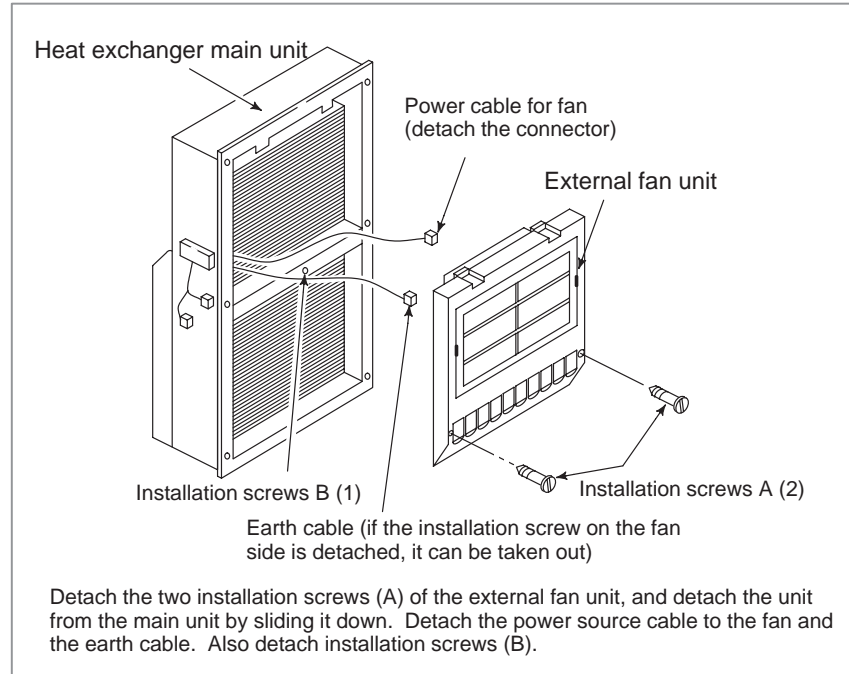

Method of cleaning fan unit

- 1 Wipe the dirt, condensation, etc., which has accumulated on the fan motor and fan installation case with a dry cloth, etc. When the condensation, etc. has accumulated and the dirt is difficult to remove, soak a cloth in neutral detergent, lightly squeeze it and wipe away the dirt.

However, take care not to allow the detergent to enter the electrical sections such as the internal rotor of the fan motor.

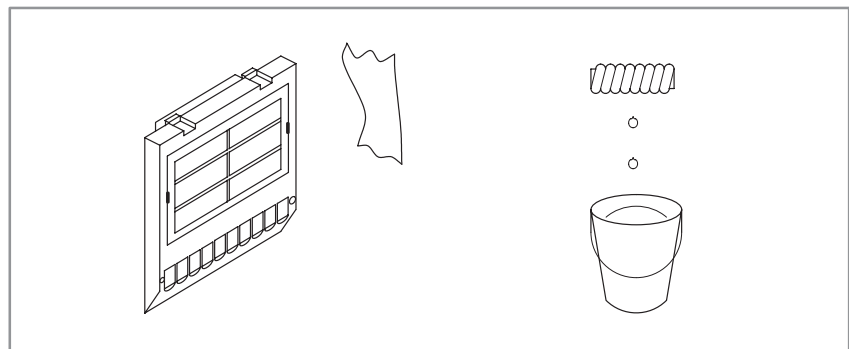

Method of cleaning heat exchanger fan

- 1 Detach the heat exchanger format the unit and either blow off with air, wipe off with a dry cloth, or brush the accumulated dirt, condensation, etc.

When the dirt is especially severe

- 1 Detach the internal fan unit, the terminal unit, and the cable from the main unit.

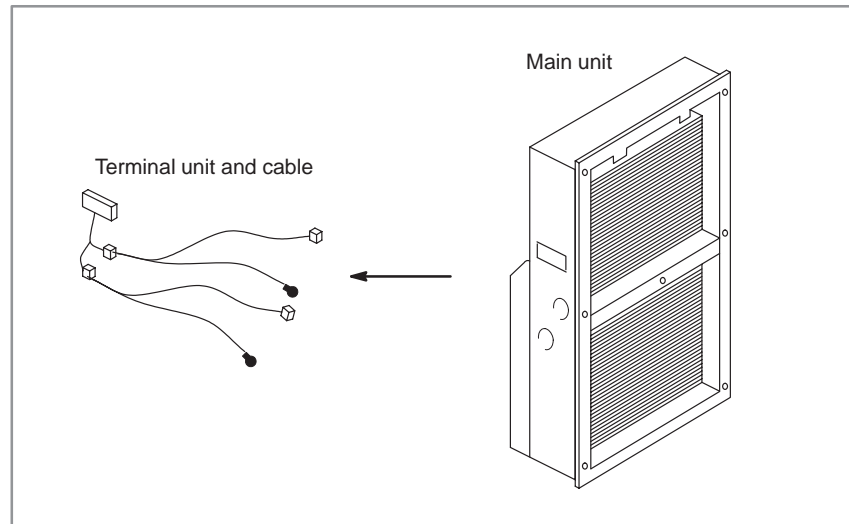

- 2 Using a neutral detergent, remove the dirt from the main unit fan section by brushing. At this time, take care not to bend the fin of the element.
- 3 After cleaning, dry well.

Method of installation after cleaning

After completing cleaning of the fan unit and heat transformer.

- 1 Install the terminal unit and cable in the original position.
- 2 Install the fan unit in the original position. At this time, do not forget to connect the fan power cable and the earth cable.

2.12 ADJUSTING THE LIQUID-CRYSTAL DISPLAYS

The liquid-crystal displays have controls for fine adjustment of the video signal. These are required to adjust any horizontal dot shift and/or flicker of the screen caused by a slight mismatch between the NC and the cable being used.

2.12.1 9.5" LCD

9.5" color liquid-crystal display (rear)

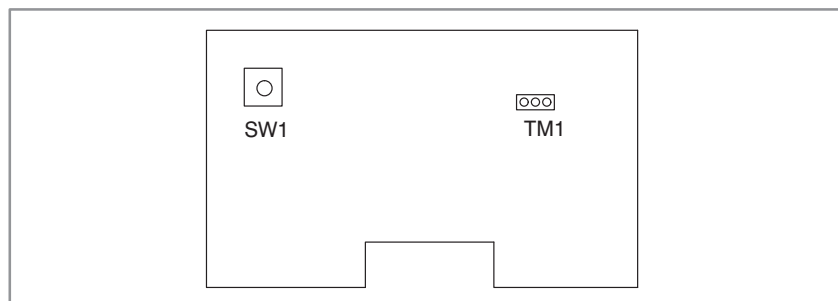

- **Adjusting for flicker (TM1)**
- **Horizontal shift of the screen display (SW1)**
- **Other**

If any flicker is observed, switch TM1 to the other setting. Usually, selecting one of the two settings will eliminate any flicker.

- 1 The display screen can be shifted horizontally one dot at a time.
- 2 Set SW1 so that all information to be displayed appears on the screen. There is only one optimal position. The liquid-crystal display is factory-set to the optimal position, so that the user should not have to make any change.

Never change any of the other settings or controls.

2.12.2 10" LCD

10" color liquid-crystal display (rear)

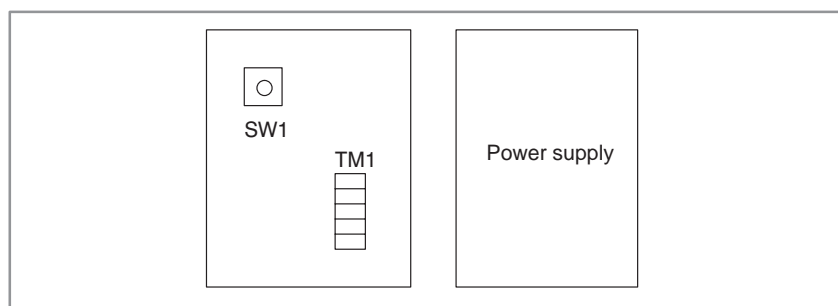

- **Adjusting for flicker (TM1)**
- **Horizontal shift of the screen display (SW1)**
- **Other**

- 1 By change the setting until the flicker is eliminated.
- 2 If each of several settings eliminates the flicker, select that setting which best corresponds to the midpoint.
Example: If no flicker occurs with settings [1] through [6], select [4].

- 1 The display screen can be shifted horizontally one dot at a time.
- 2 Set SW1 so that all information to be displayed appears on the screen. There is only one optimal position. The liquid-crystal display is factory-set to the optimal position, so that the user should not have to make any change.

- Never change any of the other settings or controls.
- Never change the settings of the graphic function built-in 10.4" LCD.
- Never change the settings of the 10.4" LCD (for MMC-IV).

2.12.3 10" PDP

10" plasma display (rear)

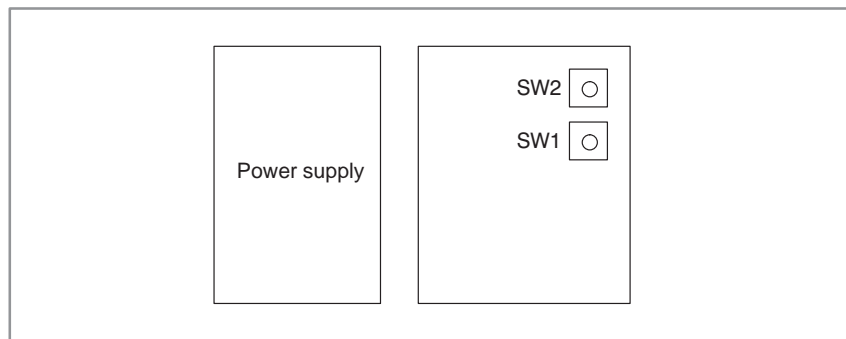

- **Adjusting for flicker (SW2)**

- 1 Change the setting until the flicker is eliminated.
- 2 If each of several settings eliminates the flicker, select that setting which best corresponds to the midpoint.

Example: If no flicker occurs with settings [1] through [6], select [4].

- **Horizontal shift of the screen display (SW1)**

- 1 The display screen can be shifted horizontally one dot at a time.
- 2 Set SW1 so that all information to be displayed appears on the screen. There is only one optimal position. The plasma display is factory-set to the optimal position, so that the user should not have to make any change.

- **Other**

Never change any of the other settings or controls.

2.12.4 9" PDP

9" plasma display (rear)

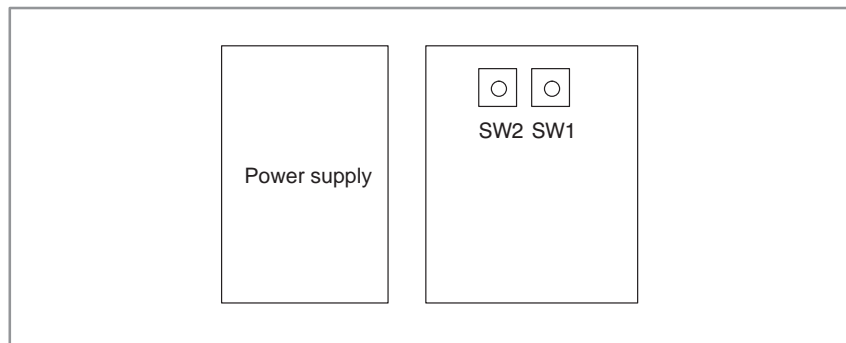

- **Adjusting for flicker (SW1)**

- 1 Change the setting until the flicker is eliminated.
- 2 If each of several settings eliminates the flicker, select that setting which best corresponds to the midpoint.

Example: If no flicker occurs with settings [1] through [6], select [4].

- **Horizontal shift of the screen display (SW2)**

- 1 The display screen can be shifted horizontally one dot at a time.
- 2 Set SW2 so that all information to be displayed appears on the screen. There is only one optimal position. The plasma display is factory-set to the optimal position, so that the user should not have to make any change.

- **Other**

Never change any of the other settings or controls.

2.13 REPLACING THE FUSES OF THE LIQUID-CRYSTAL DISPLAYS

This section describes the locations of the fuses of the liquid-crystal displays, as well as how to replace them.

2.13.1 9.5" LCD, 10.4" LCD (Graphic Function Built-in Type or for MMC-IV)

Color liquid-crystal display (rear)

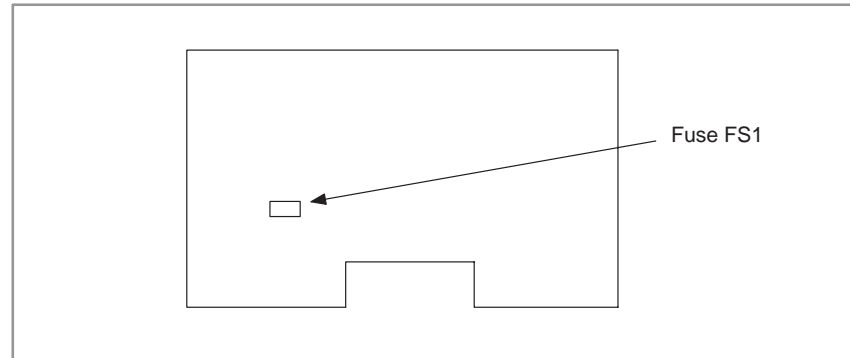

- Replacing the fuse

- 1 If the fuse has blown, first determine the cause. Always correct the cause before replacing the fuse.
- 2 Pull out blown fuse FS1, then install a new one.

- Fuse specification

Ordering drawing number : A02B-0200-K103
Capacity : 5.0 A

FANUC drawing number : A60L-0001-0290#LM50

2.13.2 10" LCD

10" color liquid-crystal display (rear)

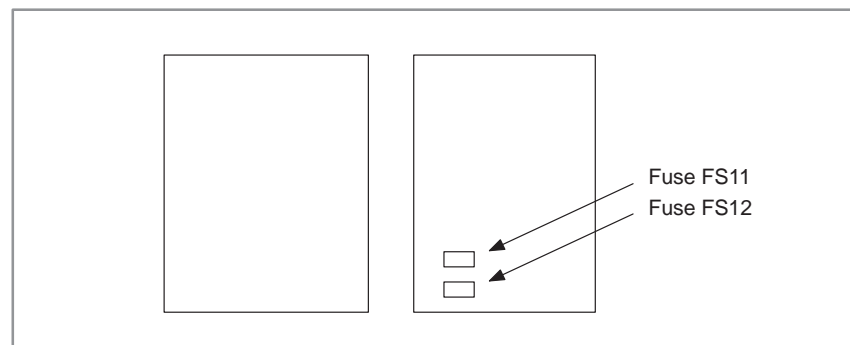

- Replacing the fuses

- 1 If a fuse has blown, determine the cause. Always to correct the cause before replacing the fuse.
- 2 Pull out the blown fuse, then install a new one.

- Fuse specification

Ordering drawing number : A02B-0120-K104
(containing one 3.2-A fuse)

Capacity : 3.2 A

FANUC drawing number : A60L-0001-0174#3.2A

2.14 REPLACING THE LCD BACKLIGHT

The LCD backlight must be replaced periodically. Replace the unit in which the LCD backlight is mounted.

The LCD backlight has a life of about 10,000 hours (5,000 hours guaranteed). (During its lifetime, the backlight should maintain a brightness exceeding 50% of that when new.)

Upon reaching the end of its service life, the LCD backlight unit must be replaced. The unit can be replaced either by the user or by a FANUC service engineer.

2.15 HOW TO REPLACE THE CRT DISPLAY

Procedure for replacing the CRT display

- 1 Disconnect the CRT unit power cable and the video signal cable.
- 2 When replacing a 9" monochrome CRT, remove the chloridized veneer cover and the four screws from the front of the CRT unit.
- 3 When replacing a 9" color CRT, remove the four screws in the front of the CRT unit.
- 4 When replacing a 14" color CRT, remove the two screws from the bottom of the CRT unit and pull it towards you.
- 5 Install the new CRT unit.
- 6 Reconnect the CRT power supply cable and video signal cable to their original positions.

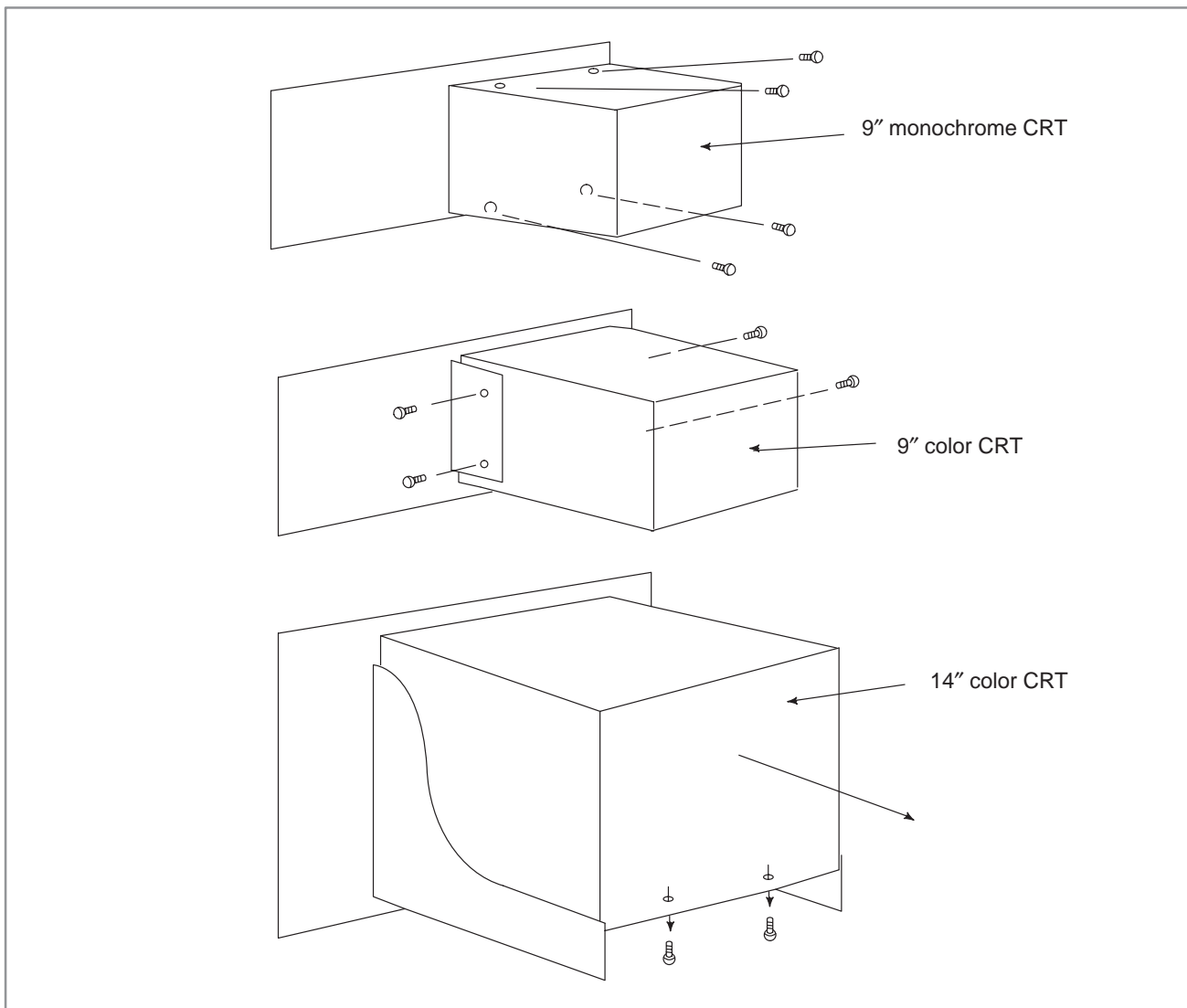

Fig. 2.15 Replacing the CRT display

2.16 HOW TO REPLACE THE MDI KEYBOARD

Procedure for replacing the MDI keyboard

- 1 The small printed circuit board at the rear of the MDI keyboard can be seen from the back of the CRT/MDI control unit. There is a flat cable, coming from the soft keyboard, attached to this printed circuit board. Disconnect this cable.
- 2 Remove the cable attached to the power on/off button.
- 3 Remove the M3 screws from the front panel attached to the sheet metal panel of the CRT/MDI unit.
- 4 The keyboard is located in between the front panel and the sheet metal panel. The keyboard can now be removed (there are no screws holding the keyboard).
- 5 Insert the new keyboard into the front panel. Screw the front panel onto the sheet metal panel.
- 6 Reattach the power on/off cable and flat cable removed in steps (1) and (2) to their original positions.

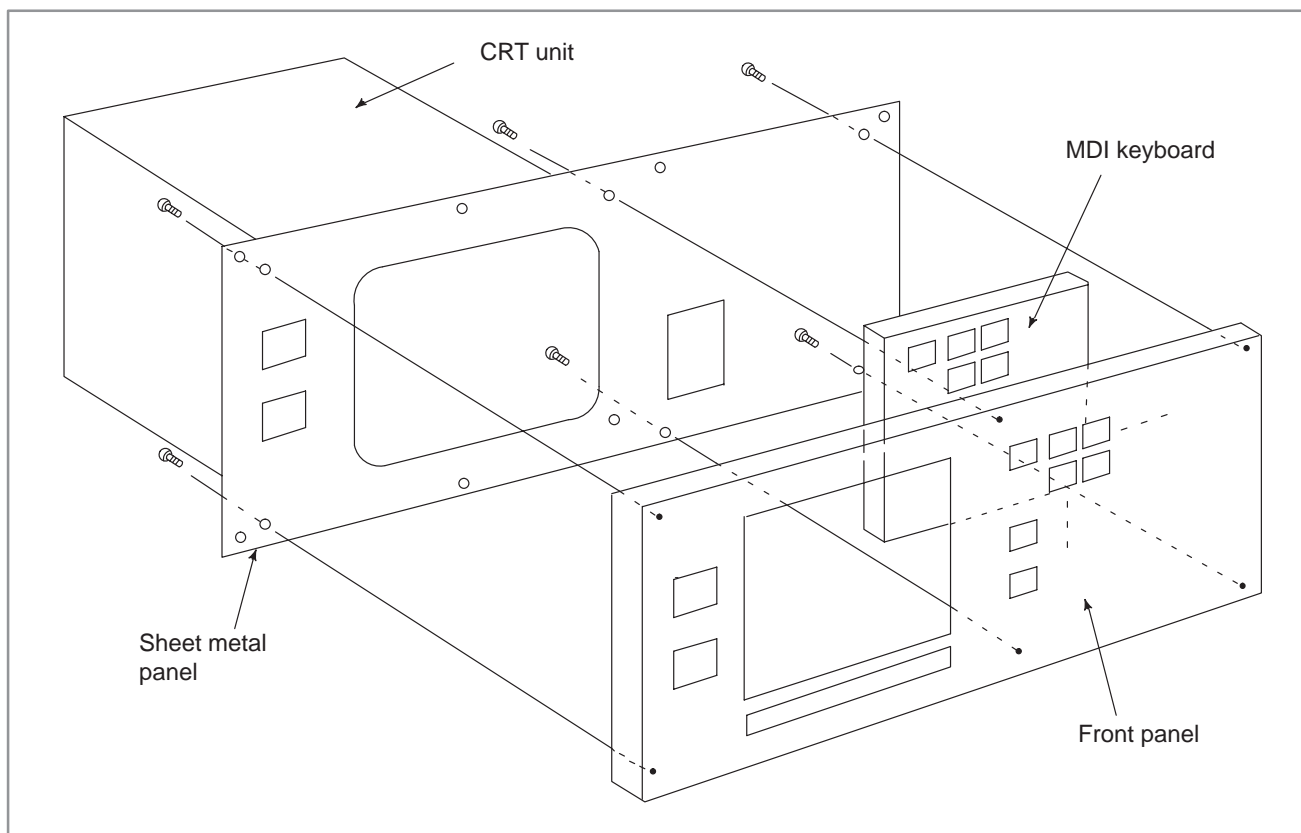

Fig. 2.16 MDI keyboard replacement

2.17 HOW TO REPLACE THE CARD CAGE IN THE CONTROL UNIT

Procedure for replacing the control unit

- 1 Turn off the power supply and disconnect all the attached cables.
- 2 Unscrew and remove the screws holding the lower portion of the rack.
- 3 The screw holes in the upper portion of the rack are made for slide-off removal. Loosen the screws and remove the rack by lifting it up and away.
- 4 Temporarily position the new rack by guiding the screws through the holes in the upper portion of the rack.
- 5 Insert the screws for affixing the lower portion of the rack, then sufficiently tighten all the screws holding the rack.
- 6 Reconnect the cables to their original positions.

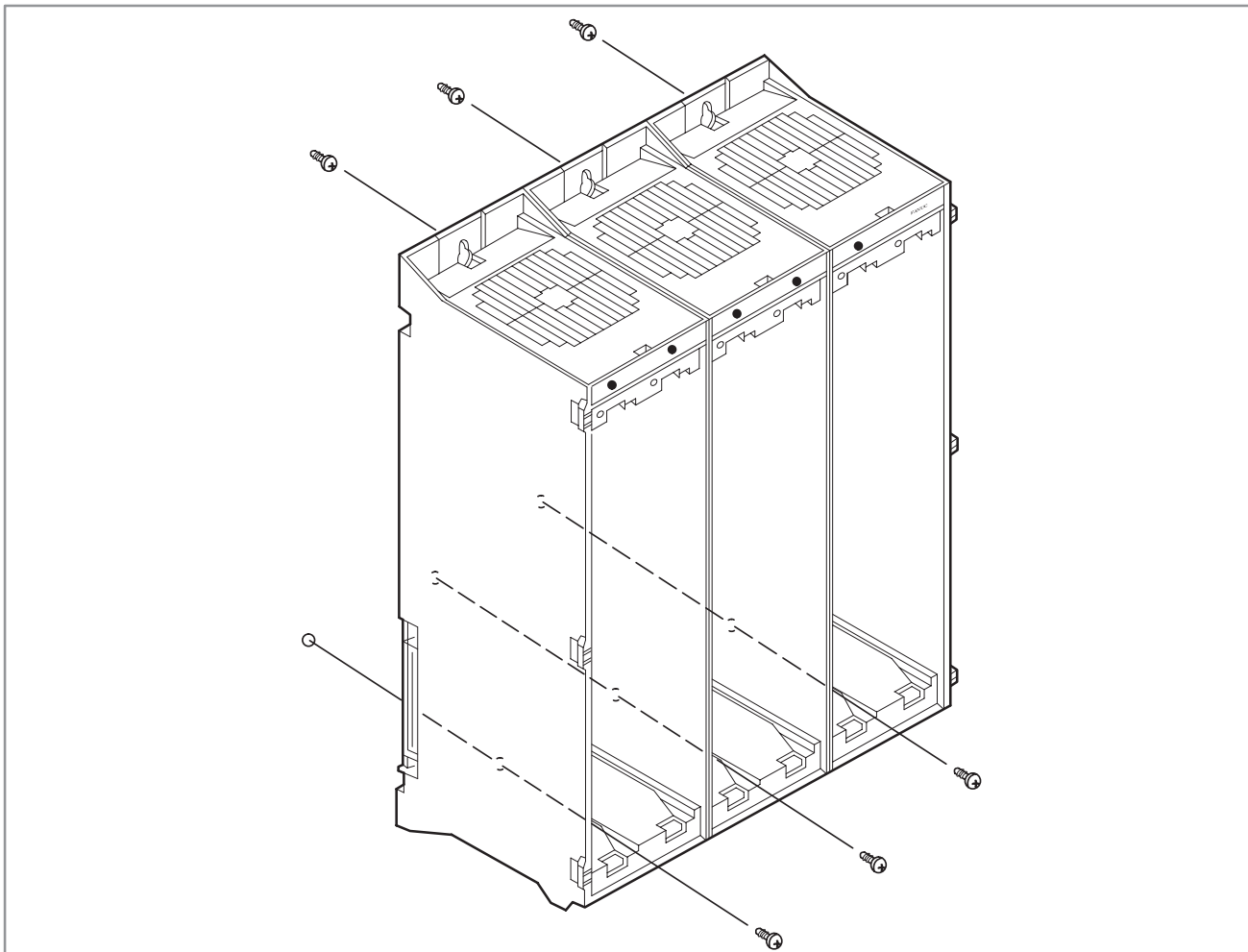

Fig. 2.17 Replacement of the control section rack

2.18 HANDLING MEMORY CARDS

2.18.1 Overview

As data exchange media, the CNC supports the use of two types of memory cards, flash memory cards and SRAM memory cards, that conform to the following standards:

- JEIDA “IC Memory Card Guideline Ver.4.0”
- PCMCIA “PC Card Standard R.2.0”

A memory card is a user-friendly data exchange medium allowing high-speed input/output. Memory cards must, however, be handled with care.

The sections below provide notes on using memory cards and describe the method of using memory cards.

Note that a flash memory card, when used with PMC-NA, can be used only with the Boot menu.

2.18.2 Notes on Use

- **Flash memory card**

(1) It is recommended that a flash memory card be backed up to a floppy disk to guard against the data on the flash memory card being destroyed or lost as a result of an accident.

- **SRAM Memory Card**

(1) An SRAM memory card requires a backup battery. SRAM memory cards are sold with no battery installed, however. Install a battery as explained in Section 2.18.5.

(2) The data stored on an SRAM memory card will be lost when the installed battery fails. Therefore, always back up the data stored on an SRAM memory card.

(3) SRAM memory cards are provided with a battery voltage detection function. If an SRAM memory card with a weak battery is connected to the CNC, the CNC displays an alarm. Note, however, that if a battery is not installed in the SRAM memory card, the battery voltage detection function will be disabled.

2.18.3 Names and Functions of the Components

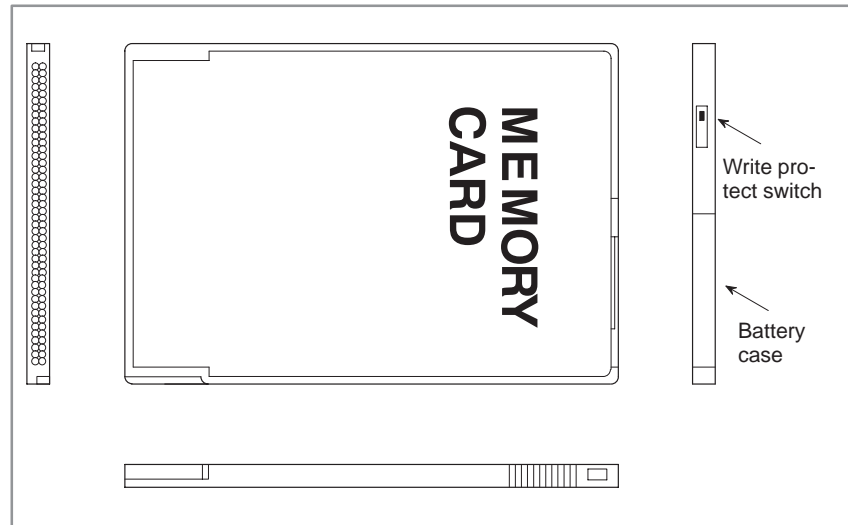

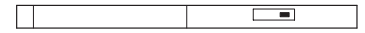
	Name	Function
1	Write protect switch	<p>Writing to the memory card can be disabled by setting the write protect switch accordingly.</p> <div style="display: flex; justify-content: space-around; align-items: center;"> <div style="border: 1px solid black; padding: 10px; text-align: center;"> <p>Writing is enabled.</p>  </div> <div style="border: 1px solid black; padding: 10px; text-align: center;"> <p>Writing is disabled.</p>  </div> </div>
2	Battery case	<p>An SRAM memory card has a battery case for housing the battery used for data backup. Flash memory cards have no battery case.</p>

2.18.4 Using Memory Cards

- **Inserting a memory card**

- (1) Carefully insert a memory card into the memory card slot, in the direction shown below.
- (2) A memory card has an insertion guide; it cannot be inserted in other than the correct orientation. When inserting a memory card, however, check its orientation.

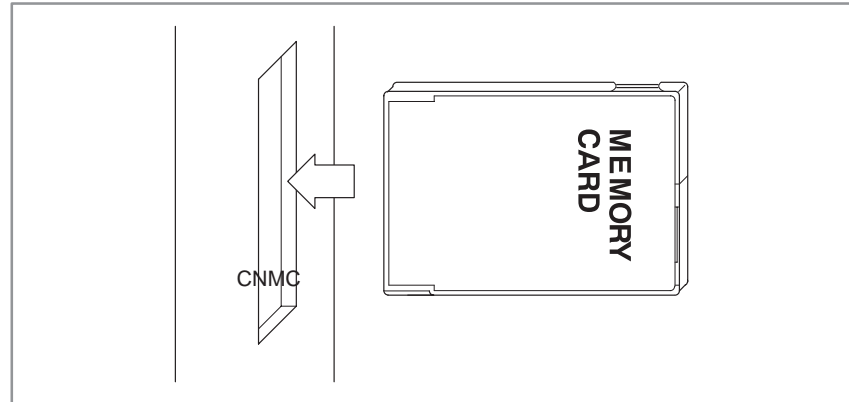

- **Operation**

- (1) For details of the write and read operations, refer to the relevant operator's manual.

- **Removing a memory card**

- (1) Pull out the memory card in the direction shown below.

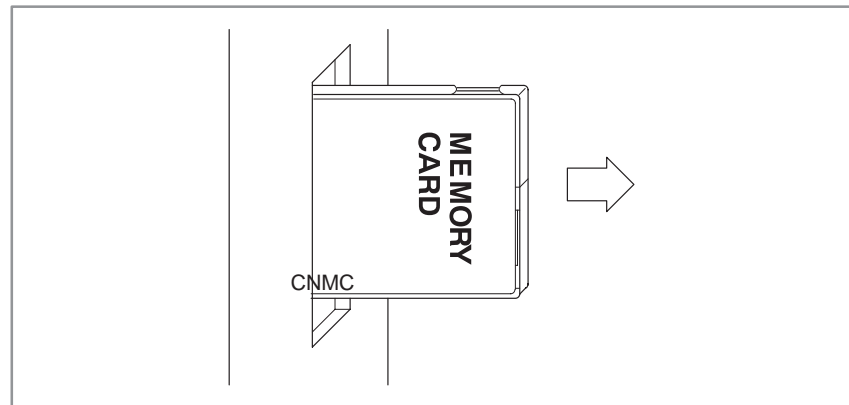

2.18.5 Replacing the Battery

- Battery
- Battery life

A BR2325 or equivalent battery is used.

The lives of batteries are listed below. Note that the life of a battery depends on its environment, including the ambient temperature. So, the values given should be used for reference only.

(Ambient temperature: 20°C)

Drawing number	Manufacturer model	Battery life
A87L-0001-0150#256K	MB98A90823-20	About 1 year
A87L-0001-0150#512K	MB98A90923-20	About 6 months
A87L-0001-0150#1M	MB98A91023-20	About 1 year
A87L-0001-0150#2M	MB98A91123-20	About 6 months

- Replacing the battery

(1) While holding down the locking clip, pull out the battery case.

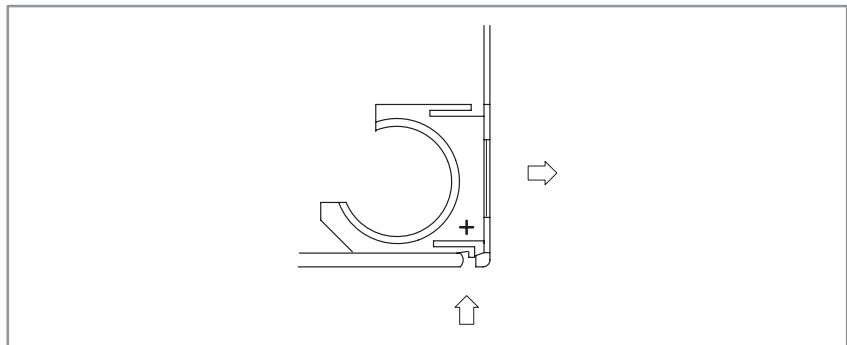

(2) Replace the battery with a new one.

Align the + mark of the new battery with the + mark on the battery case.

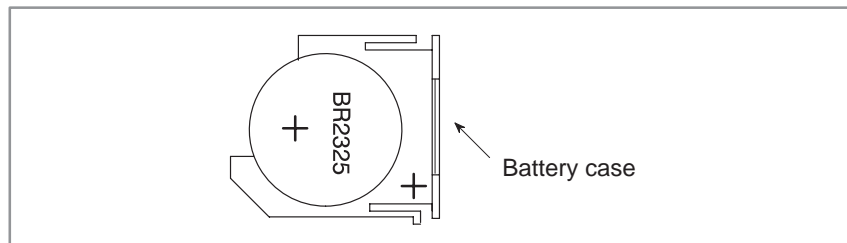

(3) Reinstall the battery case, then check that the battery operates normally.

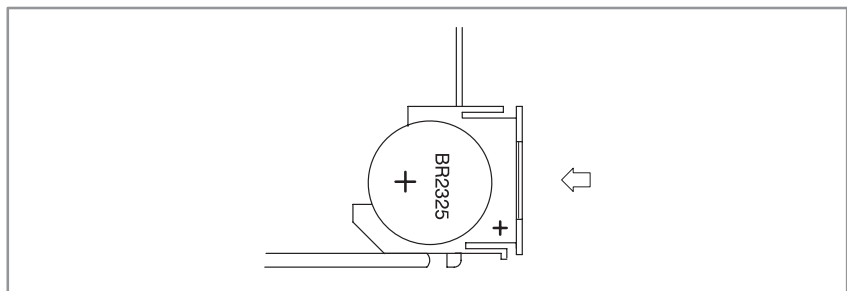

3 INPUT AND OUTPUT OF DATA



This chapter describes the methods of inputting/outputting various types of data, required settings, and so forth.



3.1	SETTING THE PARAMETERS REQUIRED FOR INPUT/OUTPUT	197
3.2	DATA INPUT/OUTPUT	200



3.1 SETTING THE PARAMETERS REQUIRED FOR INPUT/OUTPUT

Parameter setting procedure

Procedure

- 1 Enable parameter writing.
 - (1) Set the MDI mode or emergency stop state.
 - (2) When the MDI mode is selected instead of the emergency stop state, switch memory protection key KEY2 to ON.
 - (3) Display the general setting screen.
 - 1) Press the  key.
 - 2) Press the  function menu key.
 - 3) Press the [CHAPTER] soft key.
 - 4) Press the [GENERAL] soft key.

The general setting screen can also be displayed by pressing the  key several times.
 - (4) Set bit 0 of setting data No. 8000 to 1.
 - 1) Key in 8000, then press the [INP-NO.] soft key.
 - 2) Press  and .

Then, the “SW000 parameter write switch on” alarm is issued.
- 2 Display the parameter screen.
 - (1) Press the  key.
 - (2) Press the  function menu key.
 - (3) Press the [CHAPTER] soft key.
 - (4) Press the [PARAM] soft key.

The parameter screen can also be displayed by pressing the  key several times.
- 3 Set parameters.

Press the  operation menu key. Then, the operation menu shown below appears in the soft key menu field.

 - (1) INP-NO.: Searches for a parameter number.

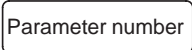
Example:  →INP-NO.
 - (2) ON : 1: Sets the value where the cursor is positioned to 1 (only for bit parameter).
 - (3) OFF : 0: Sets the value where the cursor is positioned to 0 (only for bit parameters).



- (4) +INPUT: Adds an input value to the data at the cursor position so that the sum is entered at the cursor position (parameters other than bit parameters).
- (5) INPUT: Enters an input value at the cursor position.
- (6) READ: Enters parameters from the reader/punch interface.
- (7) PUNCH: Outputs parameters to the reader/punch interface.

4 Ending parameter writing

After terminating parameter write operation, return bit 0 of setting data No. 8000 to 0 by using the same procedure as described in Item 1 above. Then, press  to release the SW000 alarm.

5 Simple setting methods

(1) Bit-by-bit setting

The cursor can be resized to the one-bit size by pressing the cursor keys  and , thus enabling bit-by-bit setting (only for bit parameters).

(2) Successive data setting starting at the cursor position

Data items can be successively entered by inserting  between adjacent data items.

Example 1:

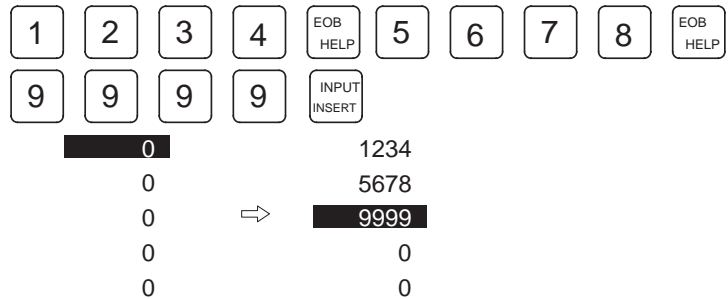

Example 2:

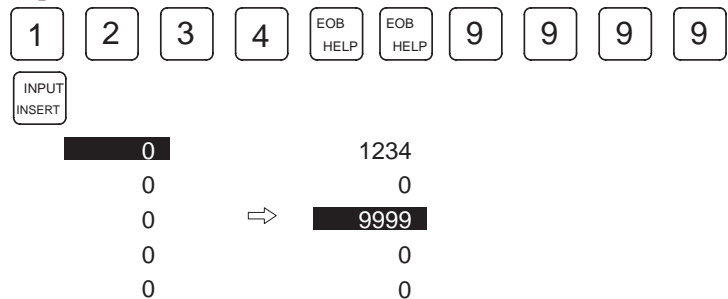

(3) Repeatedly setting the same data

The same data item can be set repeatedly by using the **0 =** key.

Example 1:

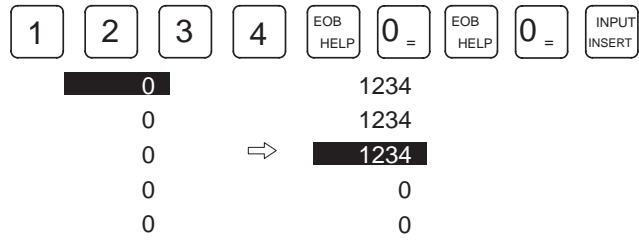

Example 2: For a bit parameter



3.2 DATA INPUT/OUTPUT

The main CPU board stores the data indicated below. While the control unit is operating normally, output the data to an I/O device beforehand.

- (1) CNC parameters
- (2) PMC parameters
- (3) Pitch error compensation data
- (4) Custom macro variable values
- (5) Tool offset data
- (6) Part programs (machining programs, custom macros)

3.2.1 Checking the Parameters Required for Data Input/Output

Correlation diagrams for parameters related to reader/punch interfaces are given below.

Parameters related to the reader/punch interface

The correlation diagrams of the parameters related to the reader/punch interface are given below.

- 1) Main CPU board + Option 1 board (with communication functions)

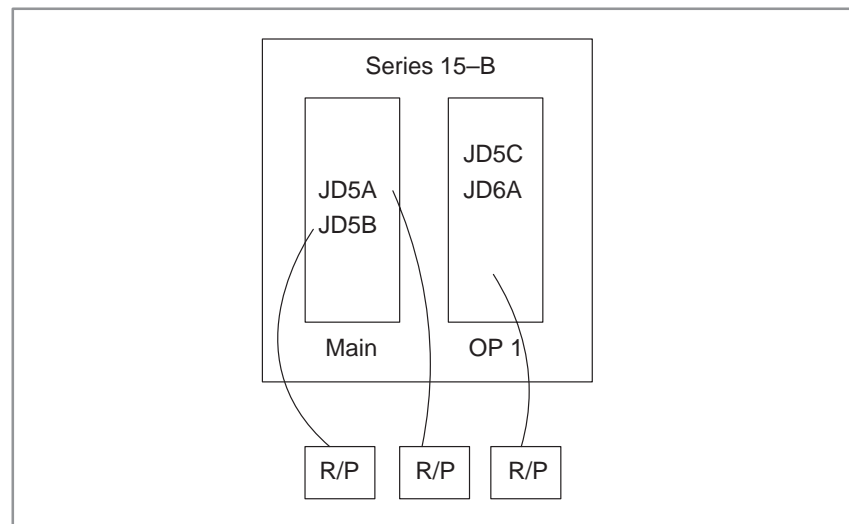

Channel 1 : JD5A of the main CPU board

Channel 2 : JD5B of the main CPU board

Channel 10 : JD5C (RS-232-C) or JD6A (RS-422) of OP1.

Only one of the two can be used.

Which is used is specified with bit 0 of parameter No. 5000.

2) Main CPU board + Additional axis board (SUB, ADAX)

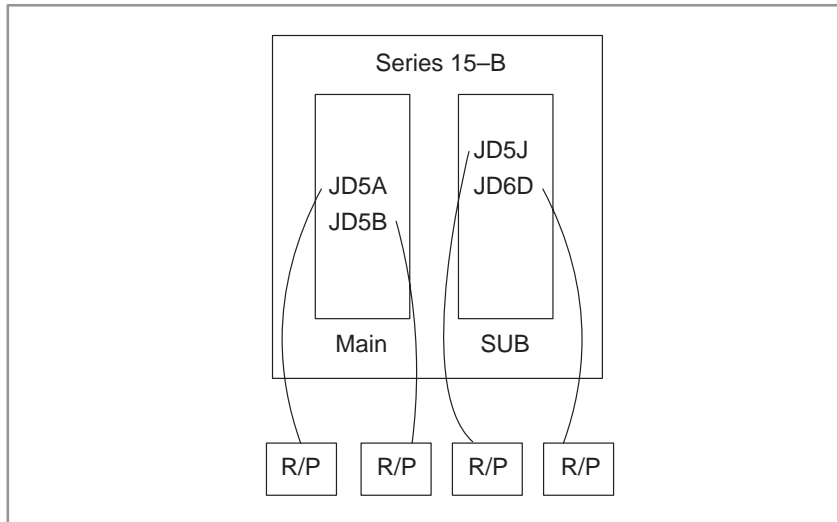

- Channel 1 : JD5A of the main CPU board
- Channel 2 : JD5B of the main CPU board
- Channel 3 : JD5J of the sub-board
- Channel 13 : JD6D of the sub-board

3) Main CPU board + Sub-board (additional axis) + Option 1 board (with communication functions)

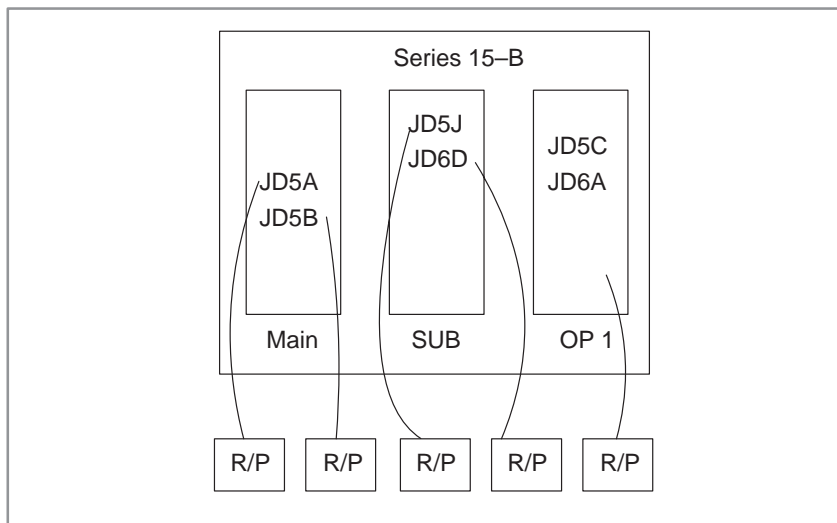

- Channel 1 : JD5A of the main CPU board
 - Channel 2 : JD5B of the main CPU board
 - Channel 3 : JD5J of the sub-board
 - Channel 13 : JD6D of the sub-board
 - Channel 10 : JD5C or JD6A of OP1.
- Only one of the two can be used.
Which is used is specified with bit 0 of parameter No. 5000.

Connector for RS-232-C : JD5A, JD5B, JD5C, JD5J

Connector for RS-422 : JD6A, JD6D

NOTE

The option 1 board contains a remote buffer.

Each reader/punch unit is temporarily assigned device numbers 1 to 6.

When you have four reader/punch units, for example, assign device numbers 1 to 4 to them.

Set the specifications of the assigned reader/punch units in parameter Nos. 5110 to 5162. Set the device numbers of the reader/punch units connected to channels 1, 2, 3, and 13 in parameter Nos. 5001, 5002, 5003, and 5013.

Set the specifications of the host computer connected to the remote buffer in parameter Nos. 5071 to 5084. A parameter that specifies which reader/punch unit is connected to channel 10 is not provided because the remote buffer is always connected to channel 10.

Parameter Nos. 0020 to 0023 select which channels are used as input/output units for foreground/background. These parameters are normally set on a dedicated screen called the SETTING HANDY screen.

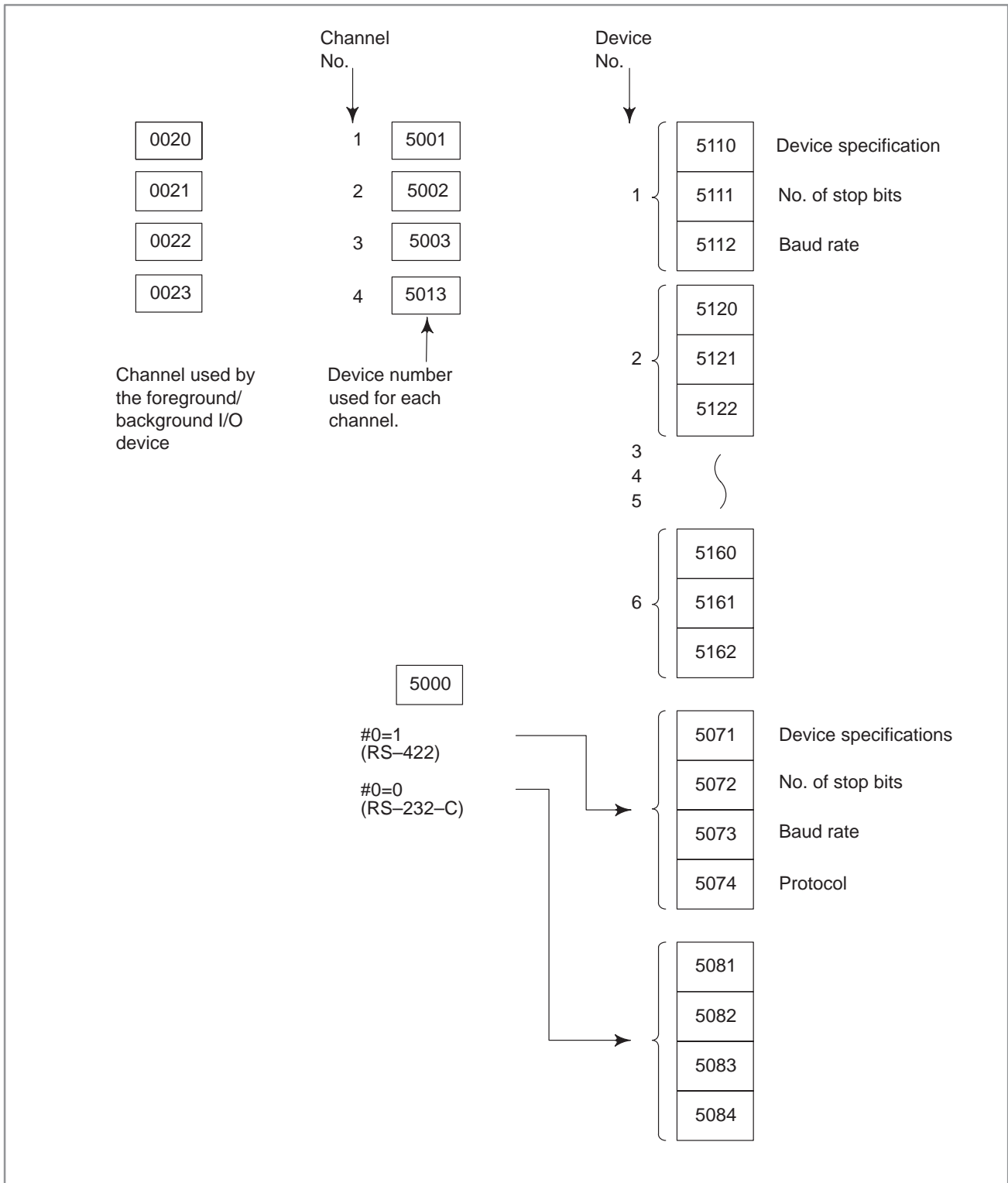

0020

Interface No. of input device for foreground

[Setting input]**[Data type]** Byte

Assignment of input device numbers for foreground

0 : Reader connected to JD5A of main CPU board

1 : Reader connected to JD5A of main CPU board (Settings 0 and 1 are identical.)

2 : Reader connected to JD5B of main CPU board

3 : Reader connected to JD5J of the subboard

4 : DNC1

9 : PMC

10: Remote buffer

13: Reader connected to JD6D of the subboard

15: MMC DNC operation interface

16: MMC upload/download interface

Perform system reset after setting this parameter.

0021

Interface No. of output device for foreground

[Setting input]**[Data type]** Byte

Assignment of output device numbers for foreground

1 : Punch connected to JD5A of main CPU board

2 : Punch connected to JD5B of main CPU board

3 : Punch connected to JD5J of the subboard

4 : DNC1

9 : PMC

10: Remote buffer

13: Punch connected to JD6D of the subboard

15: MMC DNC operation interface

16: MMC upload/download interface

Perform system reset after setting this parameter.

0022	Interface No. of input device for background
------	--

[Setting input]**[Data type]** Byte

Assignment of input device numbers for background

0 : Reader connected to JD5A of main CPU board

1 : Reader connected to JD5A of main CPU board (Settings 0 and 1 are identical.)

2 : Reader connected to JD5B of main CPU board

3 : Reader connected to JD5J of the subboard

4 : DNC1

9 : PMC

10: Remote buffer

13: Reader connected to JD6D of the subboard

16: MMC upload/download interface

Perform system reset after setting this parameter.

0023	Interface No. of output device for background
------	---

[Setting input]**[Data type]** Byte

Assignment of output device numbers for background

1 : Punch connected to JD5A of main CPU board

2 : Punch connected to JD5B of main CPU board

3 : Punch connected to JD5J of the subboard

4 : DNC1

9 : PMC

10: Remote buffer

13: Punch connected to JD6D of the subboard

15: MMC DNC operation interface

16: MMC upload/download interface

Perform system reset after setting this parameter.

5001	Device number of reader/punch unit connected to JD5A of MAIN
------	--

5002	Device number of reader/punch unit connected to JD5B of MAIN
------	--

5003	Device number of reader/punch unit connected to JD5J of additional axis board
------	---

[Setting input]**[Data type]** Byte**[Valid data range]** 1 to 6

Set the device numbers of the reader/punch units connected to connectors CD4A, CD4B, and CD4.

Set the code numbers of the reader/punch units corresponding to device numbers 1 to 6 in parameter Nos. 5100 to 5162.

5013

Device number of reader/punch unit connected to JD6D of additional axis board

[Setting input]**[Data type]** Byte**[Valid data range]** 1 to 6

Set the device number of the reader/punch unit connected to the RS-422 interface.

Set the code numbers of the reader/punch units corresponding to device numbers 1 to 6 in parameter Nos. 5110 to 5162.

5110

Code number of reader/punch unit corresponding to device number 1

[Setting input]**[Data type]** Byte**[Valid data range]** 1 to 8

Set the code number of reader/punch unit corresponding to device number 1.

The table below gives the correspondence between code numbers and specifications of reader/punch units.

Spec. number	Reader/puncher device specifications
1	Control codes (DC1-DC4) are used. A punch outputs a feed. Tape reader
2	Control codes (DC1-DC4) are not used. A punch outputs a feed.
3	Control codes (DC1-DC4) are used. A punch does not output a feed.
4	Control codes (DC1-DC4) are not used. A punch does not output a feed.
5	Portable tape reader
6	PPR, Handy File (Local mode)
7	FANUC cassette
8	Floppy cassette, PROGRAM FILE Mate, Handy File (Remote mode)

Be sure to set 5 to use the rewinding function with the RS-232-C interface.

5111

Number of stop bits of reader/punch unit corresponding to device number 1

[Setting input]**[Data type]** Byte**[Valid data range]** 1 to 2

Set the number of stop bits of reader/punch unit corresponding to device number 1.

5112	Baud rate of reader/punch unit corresponding to device number 1
------	---

[Setting input]**[Data type]** Byte**[Valid data range]** 1 to 12

Set the baud rate of the reader/punch unit corresponding to device number 1.

The table below gives the correspondence between the specified numbers and baud rate.

Specified number	Baud rate	Specified number	Baud rate
1	50	7	600
2	100	8	1200
3	110	9	2400
4	150	10	4800
5	200	11	9600
6	300	12	19200

5120	Code number of reader/punch unit corresponding to device number 2
------	---

5121	Number of stop bits of reader/punch unit corresponding to device number 2
------	---

5122	Baud rate of reader/punch unit corresponding to device number 2
------	---

5130	Code number of reader/punch unit corresponding to device number 3
------	---

5131	Number of stop bits of reader/punch unit corresponding to device number 3
------	---

5132	Baud rate of reader/punch unit corresponding to device number 3
------	---

5140	Code number of reader/punch unit corresponding to device number 4
------	---

5141	Number of stop bits of reader/punch unit corresponding to device number 4
------	---

5142	Baud rate of reader/punch unit corresponding to device number 4
------	---

5150	Code number of reader/punch unit corresponding to device number 5
------	---

5151	Number of stop bits of reader/punch unit corresponding to device number 5
------	---

5152	Baud rate of reader/punch unit corresponding to device number 5
------	---

5160	Code number of reader/punch unit corresponding to device number 6
------	---

5161	Number of stop bits of reader/punch unit corresponding to device number 6
------	---



5162	Baud rate of reader/punch unit corresponding to device number 6
------	---

The method for setting these parameters is the same as for setting the specifications of the input/output unit corresponding to device number 1.

3.2.2 Data Output

3.2.2.1 CNC parameter output

1 Display the parameter screen.

- 1) Press the  key.
- 2) Press the  function menu key.
- 3) Press the [CHAPTER] soft key.
- 4) Press the [PARAM] soft key.

The parameter screen can also be displayed by pressing the  key several times.

- 2 Press the  operation menu key to display [PUNCH] in the soft key menu.
- 3 Press the [PUNCH] soft key. Then, the soft key menu changes, and the [PARAM] soft key is displayed.
- 4 Press the [PARAM] soft key to start parameter output.





3.2.2.2 Outputting PMC parameter

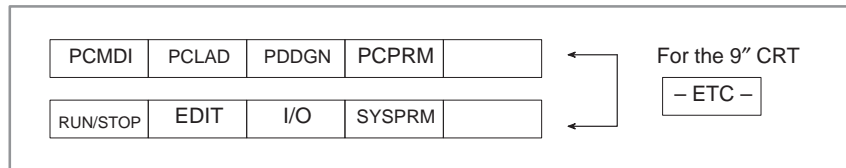

(1) Setting the input/output channel

When inputting and outputting data, the input/output channel must be correctly set. Once the input/output channel has been set, the setting is maintained even after the CNC is turned off. Therefore, further channel setting is normally not required. If the input/output channel must be again set for some reason, follow the steps below.

1. Press the  key to display the PMC screen. When the lower soft key list as shown in the figure below is displayed on the PMC screen, steps 2. to 8. are not needed.



2. Press the  key to display the NC screen. Then put the CNC in the MDI mode or emergency stop mode.
3. Press the  soft key to display the setting screen.
4. Enter 8000 and press the [INP-NO.] soft key. Parameter No. 8000 is now displayed.
5. If PWE, the lowest bit of parameter No. 8000, is set to 0, change it to 1. Then press the  soft key. This sets the PWE bit to 1 and puts the NC in the alarm mode.
6. Press the  soft key to display the PMC screen.

- Press the [PCPRM] soft key. Then press the [KEEPRL] soft key to display the keep relay screen. Press the  page key until the screen which contains the K17 data line is displayed. When this screen is displayed, place the cursor at the K17 data using the cursor keys. Then enter 10000000 and press the  soft key. This sets the highest bit of the K17 data to 1. (Keep record of the original K17 data until step 10.)

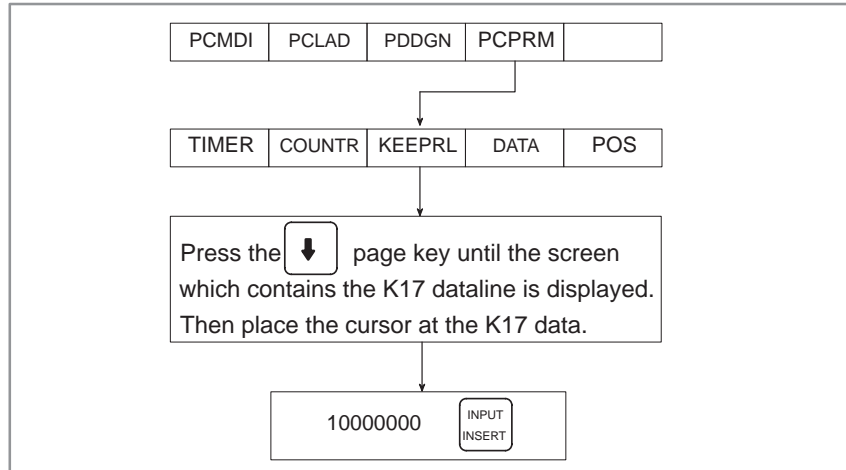

- Press the return key on the left of the soft keys several times to display the soft key menu as shown in the figure in step 1..
- Press the soft keys [I/O], [FDCAS], and [CHANEL] in that order. Then enter the valid channel number using the keyboard and press the [EXEC] key.

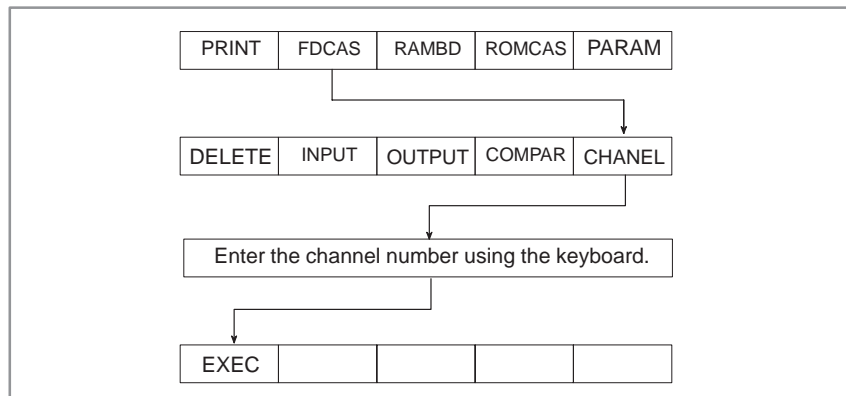

- If the K17 data for the keep relay was changed in step 7., restore it to the original setting.

NOTE

To change the baud rate, press the [PCPRM] soft key on the menu as shown in the figure in step 1., and press the MODE soft key. Then place the cursor at DATA TRANSFER RATE (AUX) using the  key. Press the soft key to display the desired baud rate.

(2) Outputting PMC data

1. Connect the reader/punch interface of the CNC to the device which outputs PMC data. Then turn the CNC on.
2. Press the NC/PC soft key to display the PMC screen.

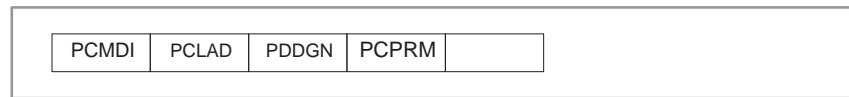

3. Press the [PCPRM] soft key to display the PC parameter screen. The soft keys are displayed as shown below.

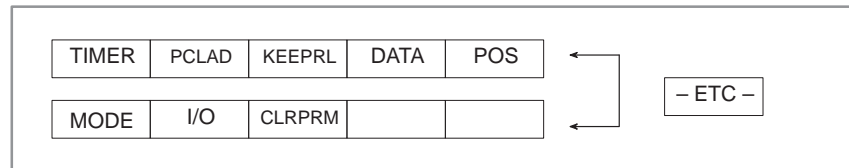

4. Press the [I/O] soft key. (For the 9" CRT, press the [-ETC-] key.)

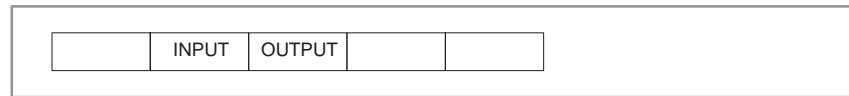

5. Press the soft keys [OUTPUT], [PARAM], and [S.FORM] in that order. Enter the file name using the keyboard and press the [ADD] key. Then the device outputs the data.

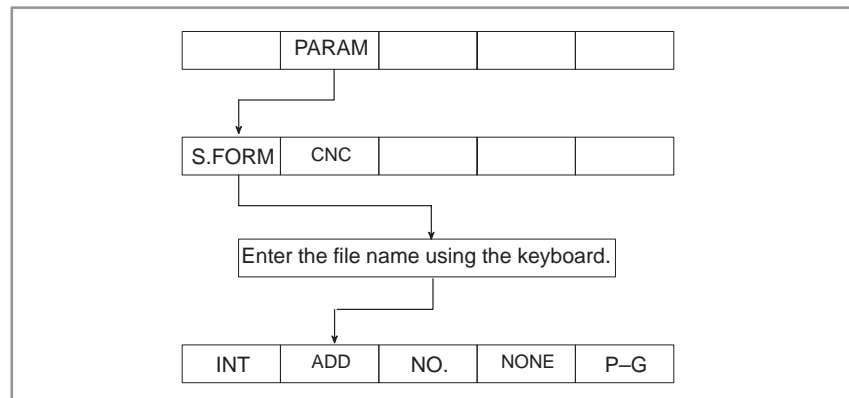



6. The corresponding addresses are displayed to show that the data is normally output.

- **PMC-NB**

(1) Connect a PMC data output device to the reader/punch interface, then turn on the power.

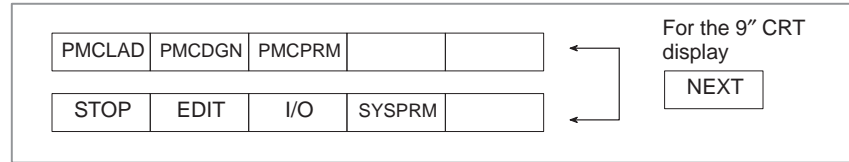
(2) Press the  key to display the PMC screen. When the soft keys in the lower row shown below are displayed, operations (1) through (9) are not required.





(3) Press the  key to display the CNC screen. Then, set the MDI mode or emergency stop state.

(4) Press the [SETTING] soft key to select the setting screen.

(5) Key in 8000, then press the [INP-NO.] soft key. Data No. 8000 is displayed.

(6) When the least significant bit (PWE) of data No. 8000 is 0, key in 1, then press the [INPUT] soft key. Then, PWE = 1 is set, and the CNC is placed in the alarm state.

(7) Press the  key to display the PMC screen.

(8) Press the [PCMCPRM] soft key then the [KEEPRL] soft key. A list of keep relays is displayed. Position the cursor, using the  key, to the K17 data then key in 10. Next, press the  key to set bit 1 of K17 to 1. (Memorize the K17 setting before making this modification as it will be used again in step (11).)

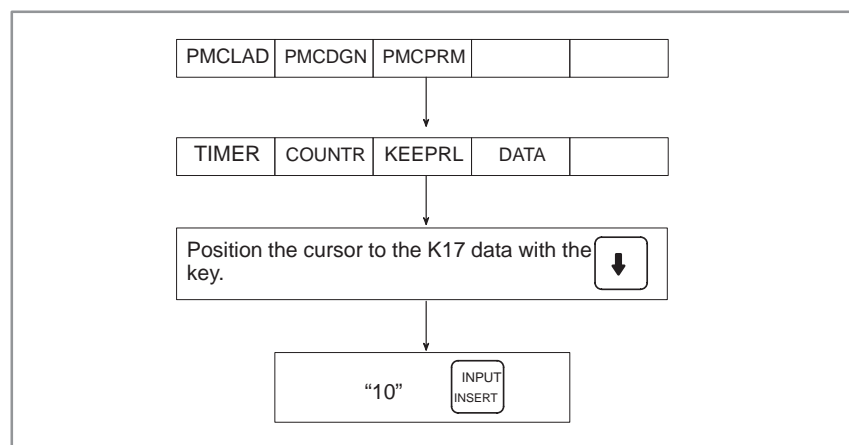

(9) Press the  key (leftmost soft key) several times to display the soft key menu of (1).

(10) Press the [I/O] soft key to display the I/O screen.

(11) Key in the correct channel number from the keyboard, then press the  key.

Example: “1”  key

- (12) Press the [FDCAS] soft key to select the FANUC Floppy Cassette as the I/O device.
- (13) Press the [PCPRM] soft key to select PMC data as the data type.
- (14) Press the [WRITE] soft key to select data output.
- (15) Enter a desired file name from the keyboard, then press the [EXEC] key.

Example: “@ABC” [EXEC] key

- **Channel number**
- **Transfer speed modification**



Channel 1: JD5A, Channel 2: JD5B

Specify a desired value on the screen, displayed by pressing the [SPEED] key on the I/O screen.

3.2.2.3

Pitch error compensation data output

- 1 Display the pitch error screen.

- 1) Press the  key.
- 2) Press the  function menu key.
- 3) Press the [CHAPTER] soft key.
- 4) Press the [PITCH] soft key.



The pitch error screen can also be displayed by pressing the  key several times.

- 2 Press the  operation menu key to display [PUNCH] in the soft key menu.
- 3 Press the [PUNCH] soft key. Then, the soft key menu changes again to display the [PITCH] soft key.
- 4 Press the [PITCH] soft key to start pitch error compensation data output.

3.2.2.4

Custom macro variable value output

- 1 Display the custom macro variable screen.



- 1) Press the  key.
- 2) Press the  function menu key.
- 3) Press the [CHAPTER] soft key.
- 4) Press the [MACRO] soft key.

The custom macro variable screen can also be displayed by pressing the  key several times.

- 2 Press the  operation menu key to display [PUNCH] in the soft key menu.
- 3 Press the [PUNCH] soft key. Then, the soft key menu changes again to display the [COMMON VARIABLE 2] soft key.
- 4 Press the [COMMON VARIABLE 2] soft key to start custom macro variable value output.

3.2.2.5**Tool offset data output**

1 Display the tool output value screen.



- 1) Press the  key.
- 2) Press the  function menu key.
- 3) Press the [CHAPTER] soft key.
- 4) Press the [TOOL] soft key.

The tool offset value screen can also be displayed by pressing the  key several times.

- 2 Press the  operation menu key to display [PUNCH] in the soft key menu.
- 3 Press the [PUNCH] soft key. Then, the soft key menu changes again to display the [TOOL] soft key.
- 4 Press the [TOOL] soft key to start tool offset data output.

3.2.2.6**Part program output**

- 1 Select edit mode.
- 2 Display the program contents screen.

- 1) Press the  key.
- 2) Press the  function menu key.
- 3) Press the [CHAPTER] soft key.
- 4) Press the [TEXT] soft key.

The program contents screen can also be displayed by pressing the  key several times.

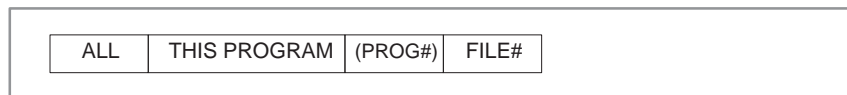

- 3 Press the  operation menu key to display [PUNCH] in the soft key menu.
- 4 Press the [PUNCH] soft key. Then, the soft key menu changes again as shown below.





- 1) Outputting all programs
Press the [ALL] soft key.
- 2) Outputting a specified program
Press the [(PROG#)] soft key, then key in a desired program number. Then, the soft key menu displays [EXEC]. Press the [EXEC] soft key to start output of the program having the specified program number.
- 3) Outputting the program currently displayed on the screen
Press the [THIS PROGRAM] soft key.

3.2.3 Data Input

3.2.3.1 CNC parameter input

- 1 Set the emergency stop state.
- 2 Display the parameter screen.
 - 1) Press the  key.
 - 2) Press the  function menu key.
 - 3) Press the [CHAPTER] soft key.
 - 4) Press the [PARAM] soft key.

The parameter screen can also be displayed by pressing the  key several times.

- 3 Check that bit 0 of setting data No. 8000 is set to 1. If the bit is set to 0, set the bit to 1 according to the parameter setting procedure described in Section 3.1.
- 4 Press the  operation menu key to display [READ] in the soft key menu.
- 5 Press the [READ] soft key. Then, the soft key menu changes again to display the [PARAM] soft key.
- 6 Press the [PARAM] soft key to start parameter input.
- 7 Upon the completion of parameter input, turn the power off, then back on again.

3.2.3.2 Inputting CNC parameter

• PMC-NA



(1) Setting the input/output channel

When inputting and outputting data, the input/output channel must be correctly set. Once the input/output channel has been set, the setting is maintained even after the CNC is turned off. Therefore, further channel setting is normally not required. If the input/output channel must be again set for some reason, follow the steps below.

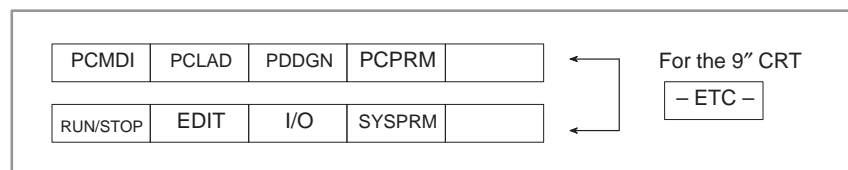
1. Press the  key to display the PMC screen. When the lower soft key list as shown in the figure below is displayed on the PMC screen, steps 2. to 8. are not needed.



2. Press the  key to display the NC screen. Then put the CNC in the MDI mode or emergency stop mode.

3. Press the [SETTING] soft key to display the setting screen.
4. Enter 8000 and press the [INPU-NO.] soft key. Parameter No. 8000 is now displayed.
5. If PWE, the lowest bit of parameter No. 8000, is set to 0, change it to 1. Then press the [INPUT] soft key. This sets the PWE bit to 1 and puts the NC in the alarm mode.
6. Press the  key to display the PMC screen.
7. Press the [PCPRM] soft key. Then press the [KEEPRL] soft key to display the keep relay screen. Press the  page key until the screen which contains the K17 data line is displayed. When this screen is displayed, place the cursor at the K17 data using the cursor keys. Then enter 10000000 and press the  key. This sets the highest bit of the K17 data to 1. (Keep record of the original K17 data until step 10.)

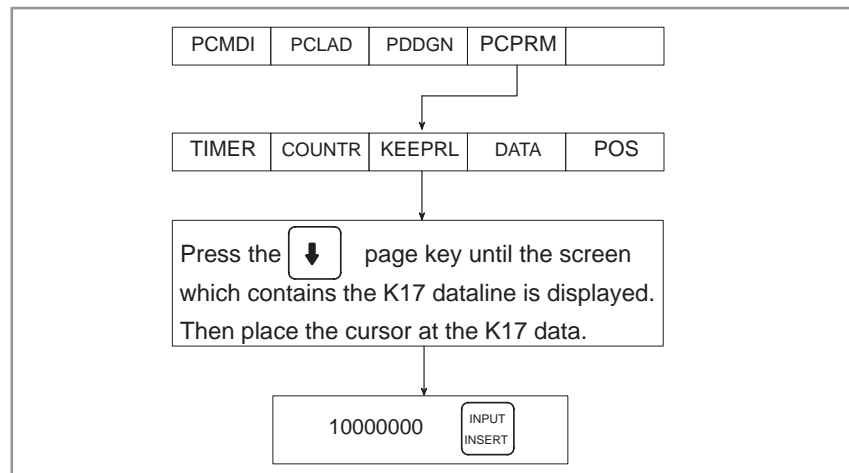

8. Press the return key on the left of the soft keys several times to display the soft key menu as shown in the figure in step 1.
9. Press the soft keys [I/O], [FDCAS], and [CHANEL] in that order. Then enter the valid channel number using the keyboard and press the [EXEC] key.

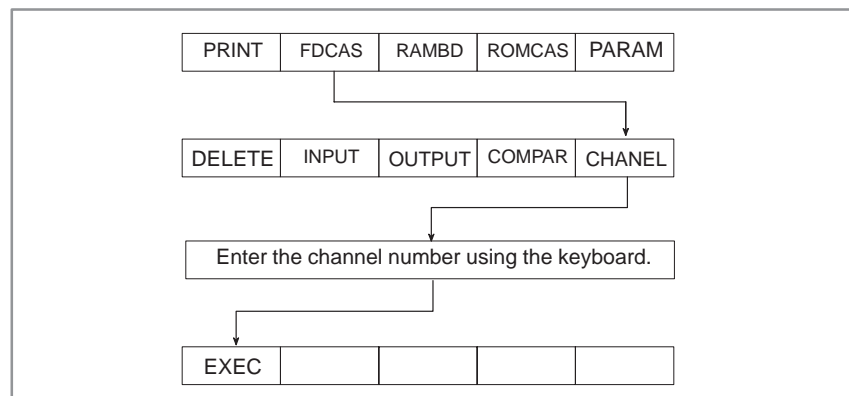

10. If the K17 data for the keep relay was changed in step 7., restore it to the original setting.

NOTE

To change the baud rate, press the [PCPRM] soft key on the menu as shown in the figure in step 1., and press the [MODE] soft key. Then place the cursor at DATA TRANSFER RATE (AUX) using the  key. Press the soft key to display the desired baud rate.

3.2.3.3 Inputting PMC data

1. Connect the reader/punch interface of the CNC to the input device which contains PMC data. Then turn the CNC on.
2. Put the CNC in the MDI mode or emergency stop mode.
3. Press the [SETTING] soft key to display the setting screen.
4. Enter 8000 and press the [INP-NO.] softkey. Parameter No. 8000 is displayed.
5. If PWE, the lowest bit of parameter No. 8000, is set to 0, change it to 1. Then press the [INPUT] soft key. This sets the PWE bit to 1 and puts the NC in the alarm mode.
6. Press the  soft key to display the PMC screen.

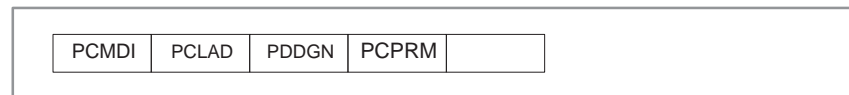

7. Press the PCPRM soft key to display the PC parameter screen. The soft keys are displayed as shown below.

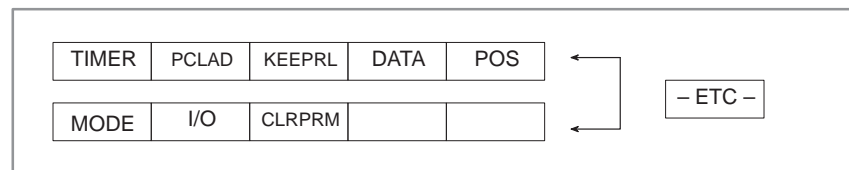

8. Press the I/O soft key. (For 9" CRT, press the [-ETC-] key.)

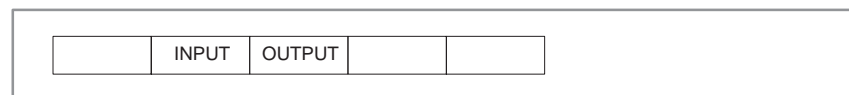

9. Press the INPUT soft key. Then enter the name or number of the file and press the [EXEC] key.

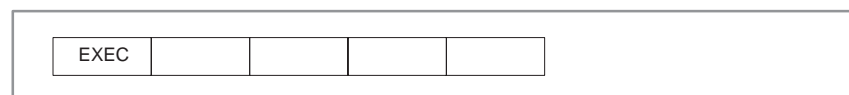

10. The corresponding addresses are displayed to show that the data has been correctly input.





NOTE

When data is read, if RAM ENABLE OFF is displayed, this means that the RAM for the PMC is protected. Press the [MODE] soft key on the menu as shown in the figure in step 7., Then place the cursor at RAM ENABLE using the  key and press the [ON] softkey.

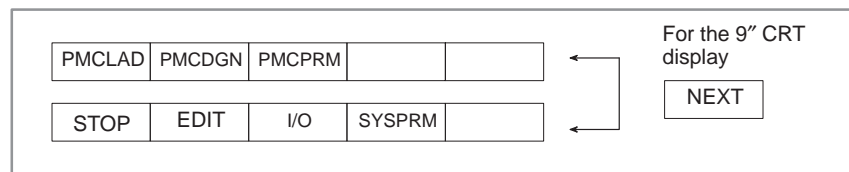

● **PMC-NB**

- (1) Connect a PMC data input device to the reader/punch interface, then turn on the power.
- (2) Press the  key to display the PMC screen. When the soft keys in the lower row shown below are displayed, operations (1) through (9) are not required.

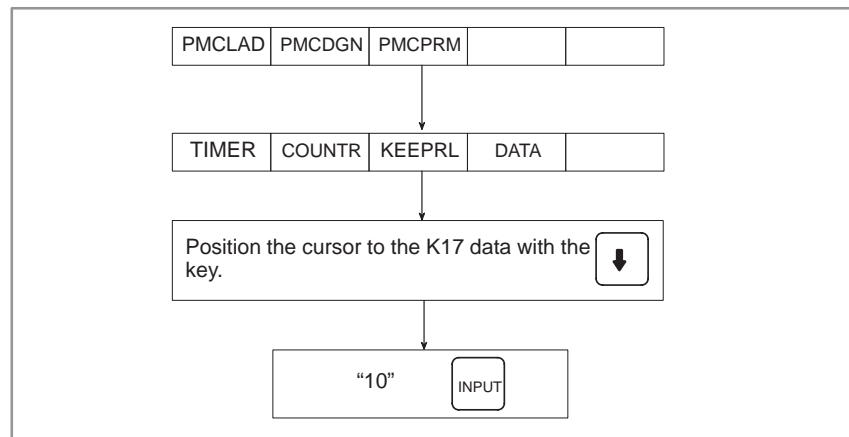

- (3) Press the  key to display the CNC screen. Then, set MDI mode or the emergency stop state.
- (4) Press the [SETTING] soft key to select the setting screen.
- (5) Key in 8000, then press the [INP-NO.] soft key. Data No. 8000 is displayed.
- (6) When the least significant bit (PWE) of data No. 8000 is 0, key in 1, then press the [INPUT] soft key. Then, PWE = 1 is set, and the CNC is placed in the alarm state.
- (7) Press the  key to display the PMC screen.
- (8) Press the [PCMCPRM] soft key then the [KEEPRL] soft key. A list of keep relays is displayed. Position the cursor, using the  key, to the K17 data then key in 10. Next, press the  key to set bit 1 of K17 to 1. (Memorize the K17 setting before making this modification as it will be used again in step (11).)



- (9) Press the  key (leftmost soft key) several times to display the soft key menu of (1).
- (10) Press the [I/O] soft key to display the I/O screen.
- (11) Key in the correct channel number from the keyboard, then press the  key.

Example: “1”  key

- (12) Press the [FDCAS] soft key to select the FANUC Floppy Cassette as the I/O device.
- (13) Press the [READ] soft key to select data input.
- (14) Set the emergency stop state.
- (15) Enter a desired file number from the keyboard, then press the [EXEC] key.
- Example: “1” [EXEC] key

- **Channel number**



Channel 1: JD5A, Channel 2: JD5B

- **Transfer speed modification**

Specify a desired value on the screen displayed by pressing the [SPEED] key on the I/O screen.

3.2.3.4

Pitch error compensation data input



- 1 Set the emergency stop state.
- 2 Display the parameter screen.
 - 1) Press the  key.
 - 2) Press the  function menu key.
 - 3) Press the [CHAPTER] soft key.
 - 4) Press the [PITCH] soft key.

The parameter screen can also be displayed by pressing the  key several times.

- 3 Press the  operation menu key to display [READ] in the soft key menu.
- 4 Press the [READ] soft key. Then, the soft key menu changes again to display the [PITCH] soft key.
- 5 Press the [PITCH] soft key to start parameter input.
- 6 Upon the completion of pitch error compensation data input, turn the power off, then back on again.

3.2.3.5

Custom macro variable value input

- 1 Select edit mode.
- 2 Set memory protection key KEY2 to ON (KEY2 = 1).
- 3 Prepare a program for custom macro variable value input on the I/O device side.
- 4 Display the program contents screen.
 - 1) Press the  key.
 - 2) Press the  function menu key.

3) Press the [CHAPTER] soft key.

4) Press the [TEXT] soft key.

The program contents screen can also be displayed by pressing the

 key several times.

5 Press the  operation menu key to display [READ] in the soft key menu.

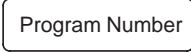

6 Press the [READ] soft key, then enter   . Next, press the [EXEC] soft key to register the program for macro variable value input.

NOTE For Program Number, enter the number of the program to be used.

7 Select memory (automatic operation) mode, then press the cycle start button to start automatic operation.

The program runs, and the custom macro values are set.

8 Upon the completion of the operation, display the custom macro variable screen.

9 By switching between pages with the page keys  and  , check that the custom macro variable values have been entered correctly.

10 Select edit mode.

11 Display the program contents screen.

12 Delete the program registered for custom macro variable value input.

Enter    to delete the program.

3.2.3.6

Tool offset data input

1 Select edit mode.

2 Set memory protection key KEY1 to ON (KEY1 = 1).

3 Prepare a program for tool offset data input on the I/O device side.

4 Display the program contents screen.

1) Press the  key.

2) Press the  function menu key.

3) Press the [CHAPTER] soft key.

4) Press the [TEXT] soft key.

The program contents screen can also be displayed by pressing the

 key several times.

5 Press the  operation menu key to display [READ] in the soft key menu.

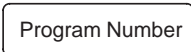

6 Press the [READ] soft key, then enter   . Next, press the [EXEC] soft key to register the program for tool offset data input.

* For Program Number, enter the number of the program to be used.

7 Select memory (automatic operation) mode, then press the cycle start button to start automatic operation.

The program runs, and the tool offset data is set.

8 Upon the completion of the operation, display the tool offset value screen.

9 By switching between pages with the page keys  and , check that the tool offset data has been entered correctly.

10 Select edit mode.

11 Display the program contents screen.

12 Delete the program registered for tool offset data input.

Enter    to delete the program.

3.2.3.7

1 Check and set the following parameters as required.

Part program registration

	#7	#6	#5	#4	#3	#2	#1	#0
0011								NE8

NE8 Specifies whether the editing of programs O8000 to O8999 is to be enabled or disabled.

0 : Enabled

1 : Disabled

	#7	#6	#5	#4	#3	#2	#1	#0
2200				NM9	NPE			

NPE Specifies whether M02, M30, and M99 are to be regarded as program end codes in program registration.

0 : Regarded as program end codes

1 : Not regarded as program end codes

NM9 Specifies whether M99 is to be regarded as a program end code in program registration.

0 : Regarded as a program end code

1 : Not regarded as a program end code

	#7	#6	#5	#4	#3	#2	#1	#0
2201							ND9	

ND9 Specifies whether the editing of programs O9000 to O9999 is to be enabled or disabled.

0 : Enabled



1 : Disabled

2 Select edit mode.

3 Set memory protection key KEY3 to ON (KEY3 = 1).

4 Prepare a program for part program input on the I/O device side.

5 Display the program contents screen.

- 1) Press the  key.
- 2) Press the  function menu key.
- 3) Press the [CHAPTER] soft key.
- 4) Press the [TEXT] soft key.

The program contents screen can also be displayed by pressing the  key several times.

- 6 Press the  operation menu key to display [READ] in the soft key menu.
- 7 Press the [READ] soft key. Then, the soft key menu changes again as shown below.

ALL	PROGRAM	(PROG#)		FILE#
-----	---------	---------	--	-------

(1) Input of all programs

Press the [ALL] soft key.

(2) Input of one program (with a program number specified)

Press the [(PROG#)] soft key, key in a desired program number, then press the [EXEC] soft key. The program is entered with the typed program number.

(3) Output of one program (with no program number specified)

Press the [PROGRAM] soft key. Then, soft keys [NEW] and [ADD] are displayed. When you press the [NEW] soft key, the program is entered with its number already assigned. When you press the [ADD] soft key, the program is entered at the end of the currently selected program.

3.2.4 15-MFB Data Input/Output

3.2.4.1 Conversational data input/output

Conversational data is read from an external storage device (reader), or punched out to an external storage device (punch). For conversational data input/output, the data input/output screen shown below, which is an auxiliary screen, is used.

DATA INPUT/OUTPUT		O1000 N01000											
1) PARAMETER	: P-9999	<input type="button" value="READ"/> No. 0060 DATA 1 OR <input type="button" value="PUNCH"/>											
2) TOOL FILE	: T-9999												
3) CUTTING CONDITION FILE	: F-9999												
4) PRE-TOOL LIST	: R-9999												
5) PASCAL	: S-9999												
6) CONVERSATIONAL DATA	: M-9999												
7) PROGRAM													
1 PROGRAM	: 0????												
ALL PROGRAM	: 0-9999												
	: 0 ???? , 0 ????												
>													
<table border="1"> <tr> <td></td> <td></td> <td>READ</td> <td>PUNCH</td> <td></td> <td></td> <td></td> <td></td> <td></td> <td></td> </tr> </table>						READ	PUNCH						
		READ	PUNCH										

As shown on the above screen, conversational data can be read or punched by entering necessary address and program number information and pressing the respective soft key. The procedure is described below.

3.2.4.2 Conversational data input

- Set a data input/output parameter.
 - Press conversational function key to display the setting screen.
 - Set a parameter required for data input/output. In the parameter, set the same data as that of the NC parameter having the same number.
- For program input, release the memory protection set using protection key KEY3.
- For parameter input, enable parameter setting by NC mode setting (PWE = 1).
- Mount the floppy disk containing the data to be entered.
- Display the data input/output screen.

6. Enter address and program number information.

Parameter	:	<input type="text" value="P<"/>	<input type="text" value="−"/>	<input type="text" value="9"/>	<input type="text" value="9"/>	<input type="text" value="9"/>	<input type="text" value="9"/>
Tool file	:	<input type="text" value="T"/>	<input type="text" value="−"/>	<input type="text" value="9"/>	<input type="text" value="9"/>	<input type="text" value="9"/>	<input type="text" value="9"/>
Cutting condition file	:	<input type="text" value="F%"/>	<input type="text" value="−"/>	<input type="text" value="9"/>	<input type="text" value="9"/>	<input type="text" value="9"/>	<input type="text" value="9"/>
Pre-tool list	:	<input type="text" value="R"/>	<input type="text" value="−"/>	<input type="text" value="9"/>	<input type="text" value="9"/>	<input type="text" value="9"/>	<input type="text" value="9"/>
PASCAL	:	<input type="text" value="S¥"/>	<input type="text" value="−"/>	<input type="text" value="9"/>	<input type="text" value="9"/>	<input type="text" value="9"/>	<input type="text" value="9"/>
Conversational data	:	<input type="text" value="M<sub>SP</sub>"/>	<input type="text" value="−"/>	<input type="text" value="9"/>	<input type="text" value="9"/>	<input type="text" value="9"/>	<input type="text" value="9"/>
All programs	:	<input type="text" value="O<sub>?</sub>"/>	<input type="text" value="−"/>	<input type="text" value="9"/>	<input type="text" value="9"/>	<input type="text" value="9"/>	<input type="text" value="9"/>

7. Press [READ] to read the specified data.

(Notes on program input)

- Specifying the conversational parameter (No. 000/RDAL) enables the entry of all programs simply by pressing [READ] without entering O-9999.
- Enter , in this order, to replace the program with a previously registered program having the same program number.

3.2.4.3**Conversational data output**

1. Set a data input/output parameter.
(See Item 1 of Section 3.2.4.2.)
2. For program output, set a desired punch code with the conversational setting data (No. 058/EIA).
3. Set the I/O device to enable output.
4. Display the data input/output screen.
5. Enter address and program number information.
(See Item 6 of Section 3.2.4.2.)
6. Press [PUNCH] to punch the specified data.

4

INTERFACE BETWEEN NC AND PMC

This chapter describes the signals between the machine operator's panel, power magnetics cabinet and the PMC, connection of the signals between PMC and CNC, and confirmation method of on/off state of these signals. It also describes system configuration of PMC, parameters of PMC, ladder and how to display time chart of the signals on the CRT. It also describes a method of inputting/outputting PMC parameters to an external device.

4.1	GENERAL OF INTERFACE	225
4.2	SPECIFICATION OF PMC	226
4.3	PMC SYSTEM CONFIGURATION	230
4.4	PMC SCREEN	231
4.5	SIGNAL AND SYMBOL CORRESPONDENCE TABLE	253

4.1 GENERAL OF INTERFACE

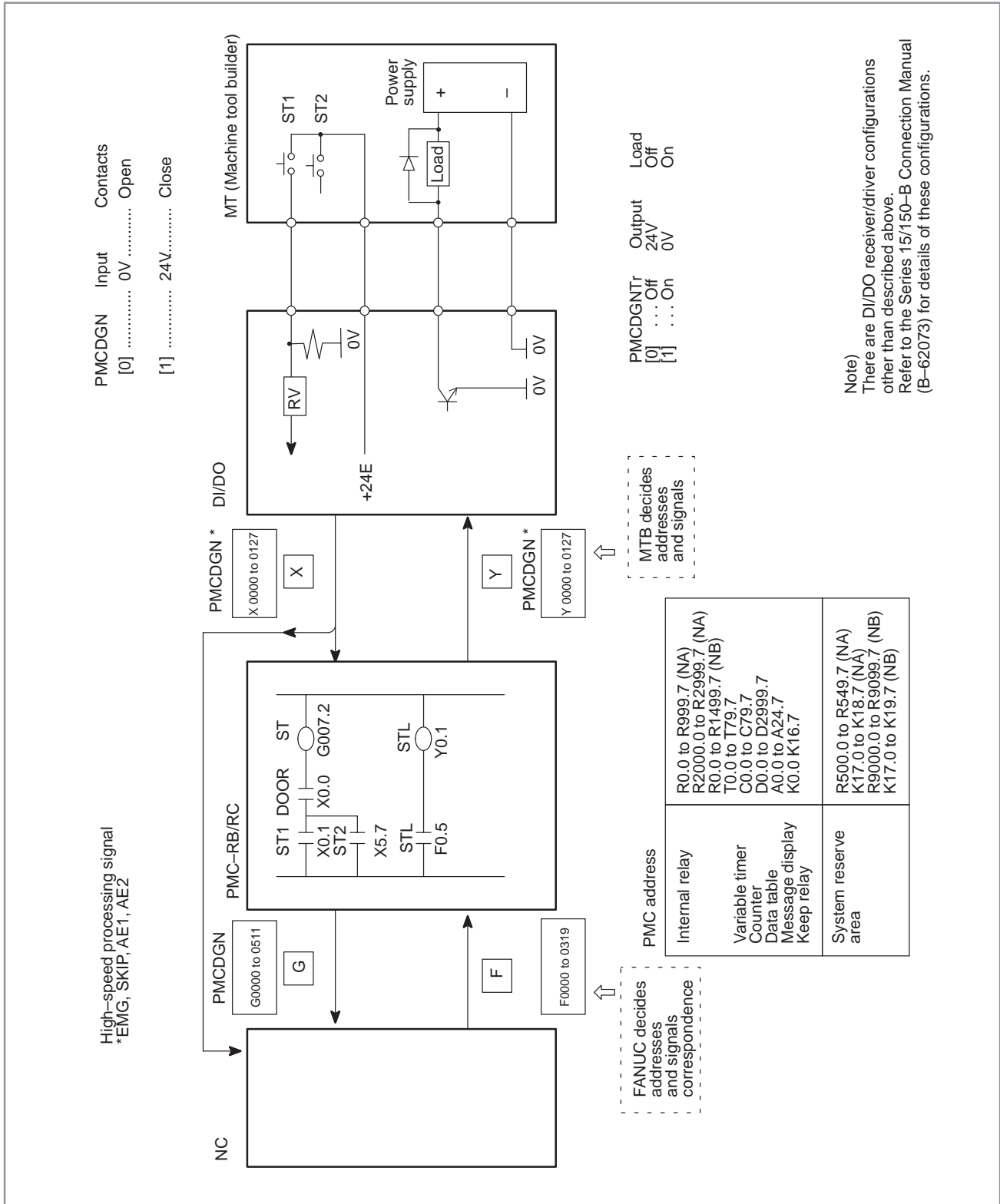

4.2 SPECIFICATION OF PMC

4.2.1 Specification

Model	PMC-RA1	PMC-RB3
Programming method language	Ladder C PASCAL	Ladder C
Number of ladder level	3	3
Level-1 Cycle Time	8 ms	8 ms
Basic Instruction Execution Time	0.2 (μ s/step)	0.1 (μ s/step)
Program capacity		
• Ladder (step)	Approx. 8,000 Approx.16,000	Approx. 8,000 Approx. 8,000 Approx.16,000 (Note2) Approx.24,000 (Note2)
• Symbol/comment (Note 1)	1 to 64KB	1 to 128KB
• Message	0.1 to 64KB	0.1 to 64KB
• Language only	Max.896KB	Max.896KB
Instruction (Basic) (Function)	12 kinds 51 kinds	14 kinds 68 kinds
Internal relay (R)	2000 byte	1618 byte
Message request (A)	25 byte	25 byte
Non-volatile		
• Var. Timer (T)	80 byte	80 byte
• Counter (C)	80 byte	80 byte
• Keep relay (K)	19 byte	20 byte
• Data table (D)	3000 byte	3000 byte
Subprogram (P)	–	512 programs
Label (L)	–	9999 labels
Fixed timer	Timer No. 100 devices specified	Timer No. 100 devices specified
Input/output		
• I/O Link (I)	1024 points max.	1024 points max.
(O)	1024 points max.	1024 points max.
Sequence program storage media	Flash memory	Flash memory

NOTE

- 1 The standard sizes of a symbol, comment, and message are as follows:

Data	PMC-NA	PMC-NB
Symbol, comment	16KB	28KB
Message	4KB	2.1KB

- 2 The use of more than about 8000 ladder program steps requires the installation of optional DRAM.

4.2.2 Address

Character	Signal description	Byte	Address	
G	PMC→CNC	512	G0.0 to G511.7	
F	CNC→PMC	320	F0.0 to F319.7	
Y	PMC→MT	128	Y0.0 to Y127.7	
X	MT→PMC	128	X0.0 to X127.7	
A	Message request signal	25	A0.0 to A24.7	
R	Internal relay (NA)	1000 50 1000	R0.0 to R499.7 R500.0 to R549.7 R2000.0 to R2999.7	Operation results (reserved by the system)
	Internal relay (NB)	1500 50 18	R0.0 to R1499.7 R9000.0 to R9099.7 R9100.0 to R9117.7	Operation results (reserved by the system)
T	Variable timer	80	T0.0 to T79.7	
K	Keep relay (NA)	17 2	K0.0 to K16.7 K17.0 to K18.7	Reserved by the system Reserved by the system
	(NB)	3	K17.0 to K19.7	
C	Counter	80	C0.0 to C79.7	
D	Data table	3000	D0.0 to D2999.7	

4.2.3 Built-in Debug Function

Function	Contents
Display of sequence program	Dynamic display of ladder diagram
Diagnostic function	<ul style="list-style-type: none"> Title data display Signal status (symbol can be displayed) PMC alarm display Signal trace Memory contents display Signal waveform display (PMC-NB only) Task status display I/O connection status display
Setting and displaying data	<ul style="list-style-type: none"> Variable timer Counter Keep relay Data table
Sequence program edit function	Ladder diagram editing

4.2.4 System Reserve Area in Internal Relay

(1) PMC-NA

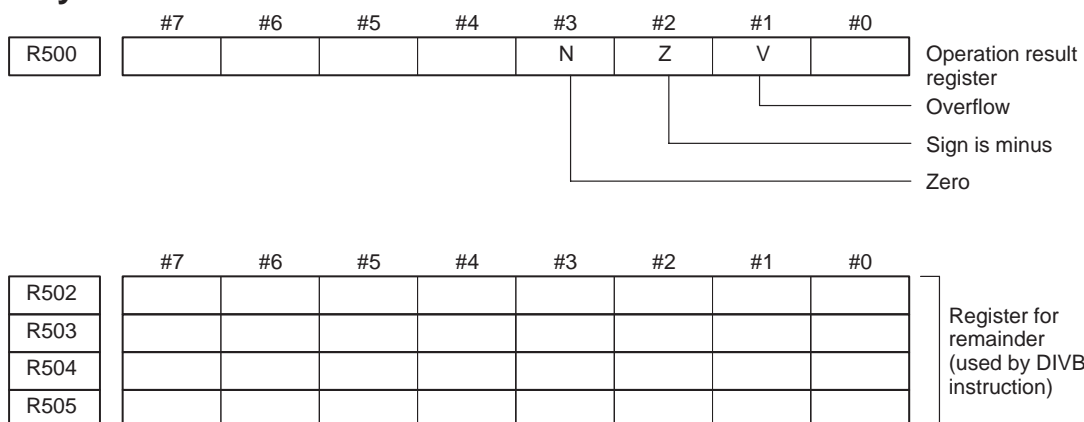

(2) PMC-NB

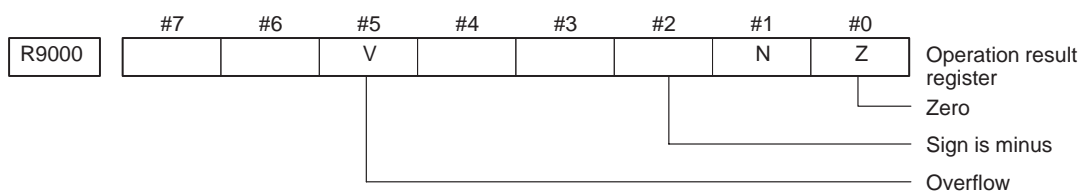

	#7	#6	#5	#4	#3	#2	#1	#0	
R9002									Register for remainder (used by DIVB instruction)
R9003									
R9004									
R9005									

4.2.5 Execution Period of PMC

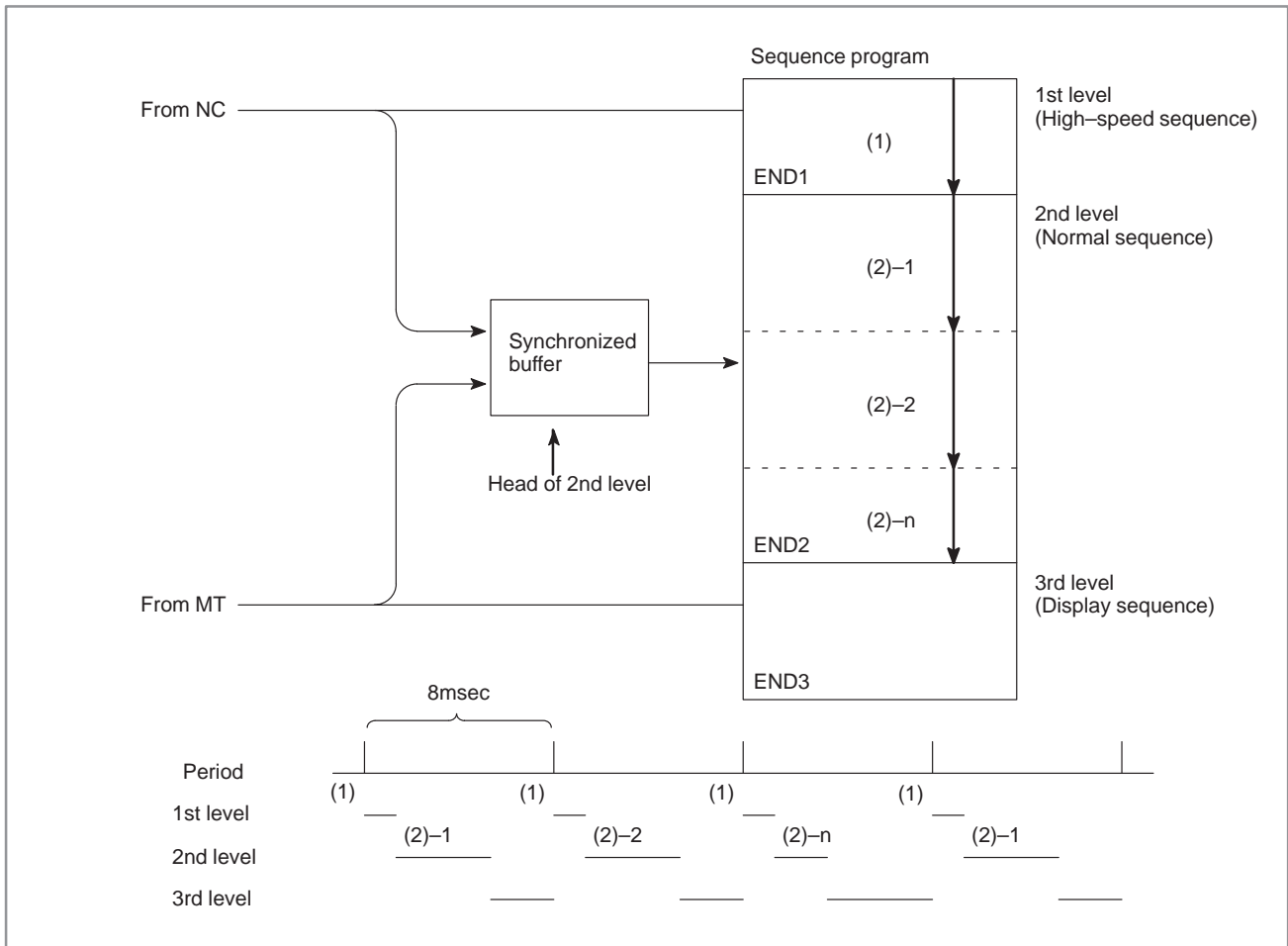

4.3 PMC SYSTEM CONFIGURATION

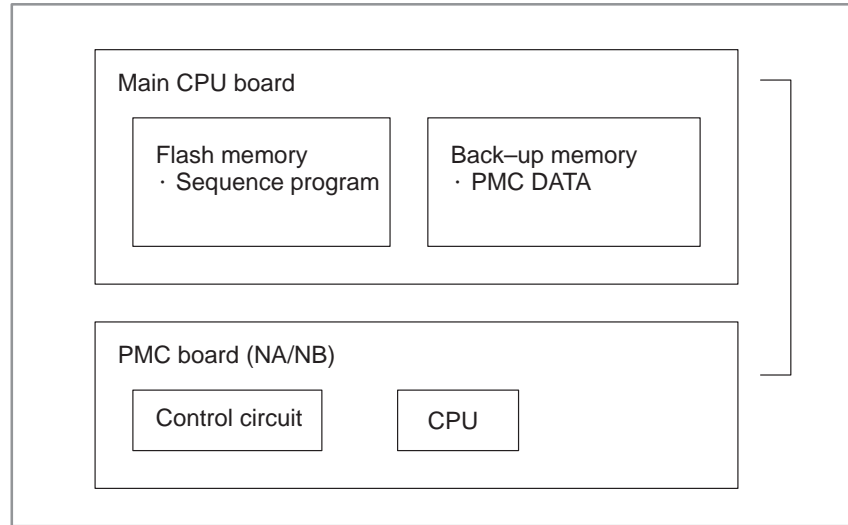

4.4 PMC SCREEN

4.4.1 Display Method

- PMC-NA

To display the PMC screen, press the  key.

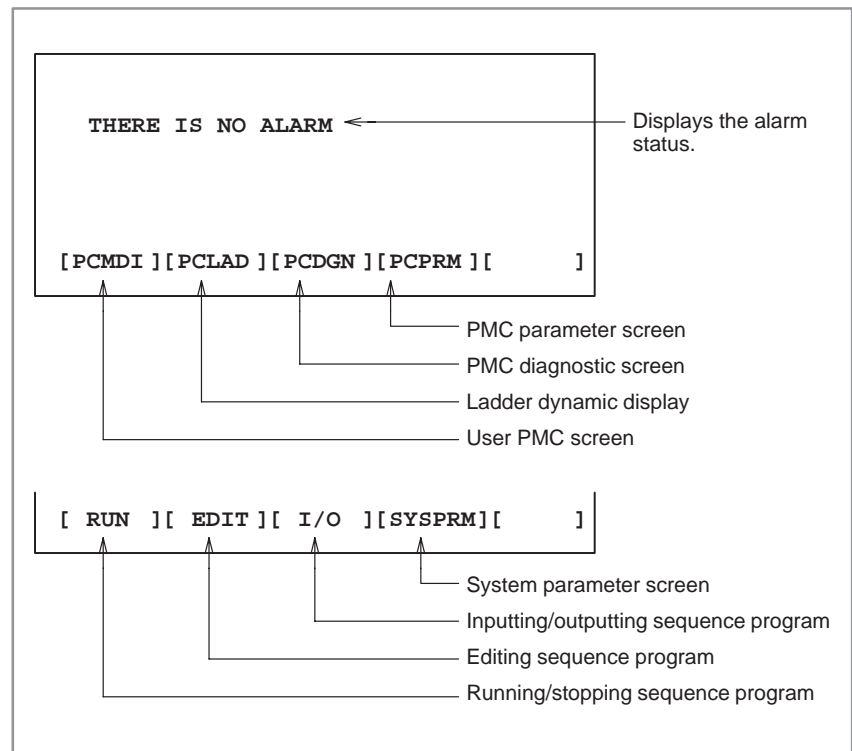

● PMC-NB

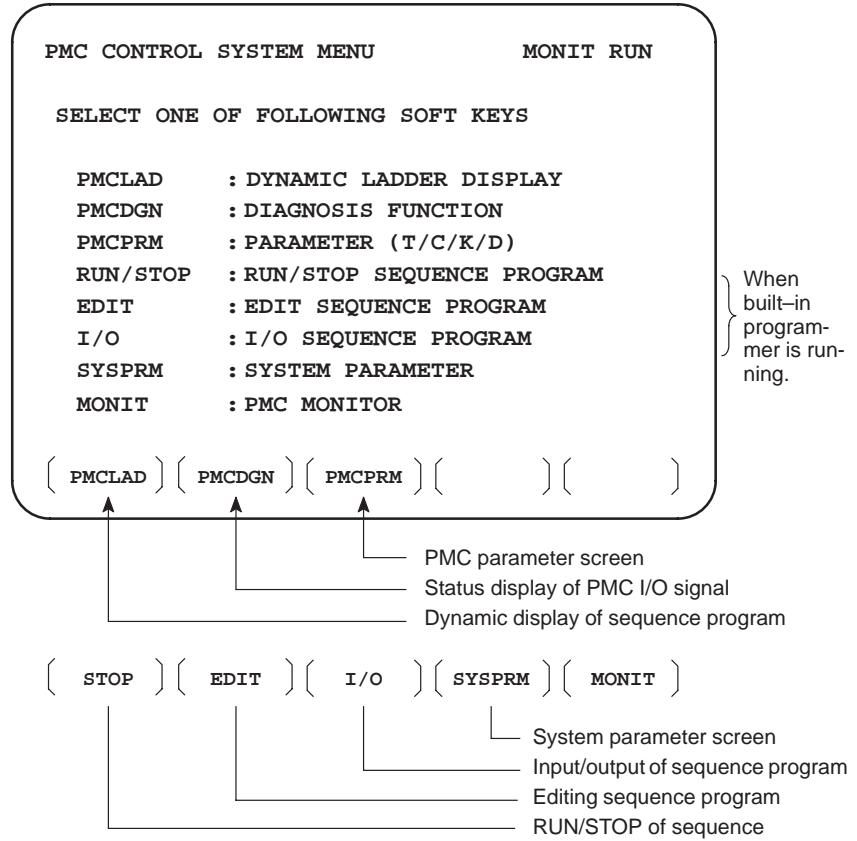

4.4.2 PMCLAD Screen

Press soft key [PMCLAD], and a sequence program is displayed dynamically and operation monitoring can be confirmed :

- PMC-NA

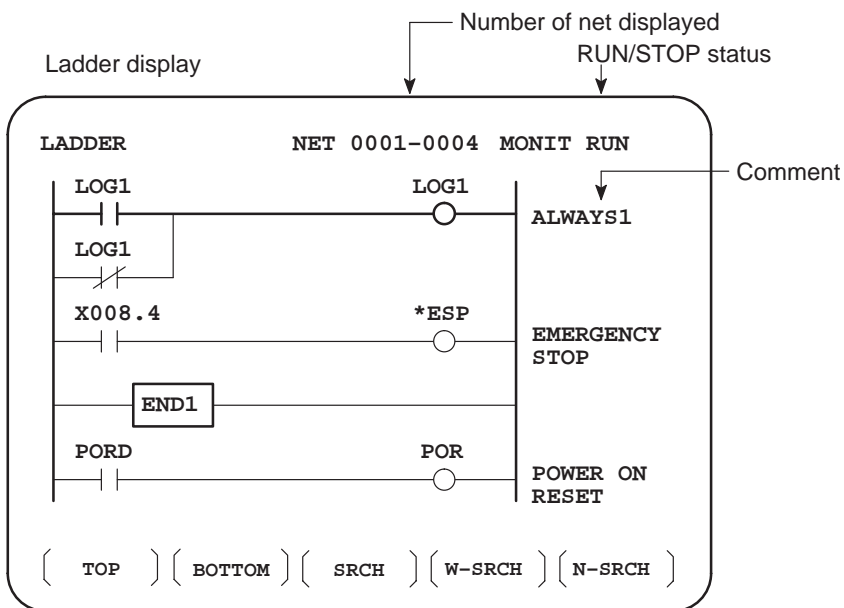

Other soft keys

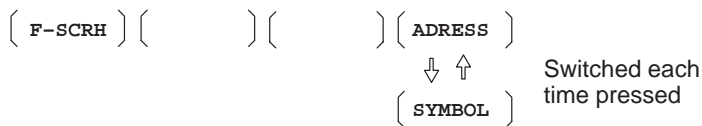

- Contents displayed

Display			Contact	Relay
Color	Monochrome PDP	Monochrome STN		
Green	Dark (low intensity)	Dark or normal video(*)	Open	Off
White	Bright (high intensity)	Bright or reverse video(*)	Close	On

* If the gray scale of the PMC mode screen is set to UNUSE, “reverse/normal video” is selected.

- **Search method**

1. Use the cursor keys to change display positions.
2. [TOP]:Searches top of ladder.
3. [BOTTOM]:Search bottom of ladder.
4. Address.bit,[SRCH] or Signal name, [SRCH]
5. Address.bit,[W-SRCH] or Signal name ,[W-SRCH]
6. Net no.[N-SRCH]:Ladder is displayed from the specified net.
7. Functional instruction no. [F-SRCH] or Functional instruction name [F-SRCH]
8. [ADDRESS]:Signal is displayed by address and bit no.
9. [SYMBOL]:Signal is displayed by signal name (symbol).
(If symbol is not registered at program preparation time, the address of the signal is displayed).

[Remarks]

- The search function searches a signal in the forward direction and displays the ladder with the searched signal at its head. Because there may exist plural contacts, repeat the search operation to find plural locations, repeat the search operation to find plural locations with the specified signal.
- If a specified signal is not found up to the end of the program (ladder), execution returns to the head of a program and search continues.

- **PMC-NB**

Press soft key [PMCLAD]. A ladder program is displayed dynamically, allowing operation monitoring to be confirmed.

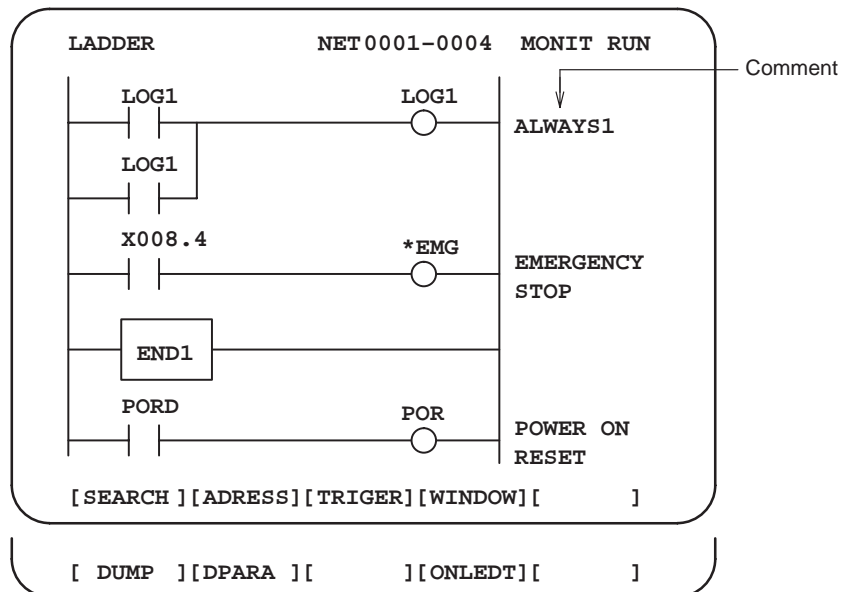

- **Contents displayed**

- (1) Green (low brightness) display
Contacts: open
Relay: off
- (2) White (high brightness) display
Contacts: closed
Relay: on

- **Search method**

(1) Use the page and cursor keys to change the display positions.

- Page keys



- Cursor keys



(2) Enter the item for which a search is to be made, then press a page or cursor key.

Enter an address and bit, then press a page or cursor key.

Enter a net number, then press a page or cursor key.

(3) Press the [SEARCH] soft key, then press any of the following soft keys:

(a) [TOP] : Displays the first net of the ladder program.

(b) [BOTTOM]: Displays the last net of the ladder program.

(c) [SRCH] : Searches for the specified address and bit number, or symbol.

“address.bit,” “address,” or “symbol”

Example: “X0.0” [SRCH] key

(d) [W-SRCH]: Searches for a relay coil according to the specified address and bit number, or symbol.

“address.bit,” “address,” or “symbol”

Example: “Y0.0” [W-SRCH] key

(e) [N-SRCH] : Searches for a net number.

“net-number”

(f) [F-SRCH] : Searches for a functional instruction.

“functional-instruction-number” or “functional-instruction-name”

Example: “1” [F-SRCH]

“END1” [F-SRCH]

● **Changing the display method**

- (1) Address or symbol display
 - (a) [ADDRESS] : Displays a signal using an address and bit number.
 - (b) [SYMBOL]: Displays a signal using a symbol.
(Signals for which no symbol has been registered are displayed using an address and bit number.)

(2) Dump display

[DUMP] : Displays the signal status at the bottom of the screen.

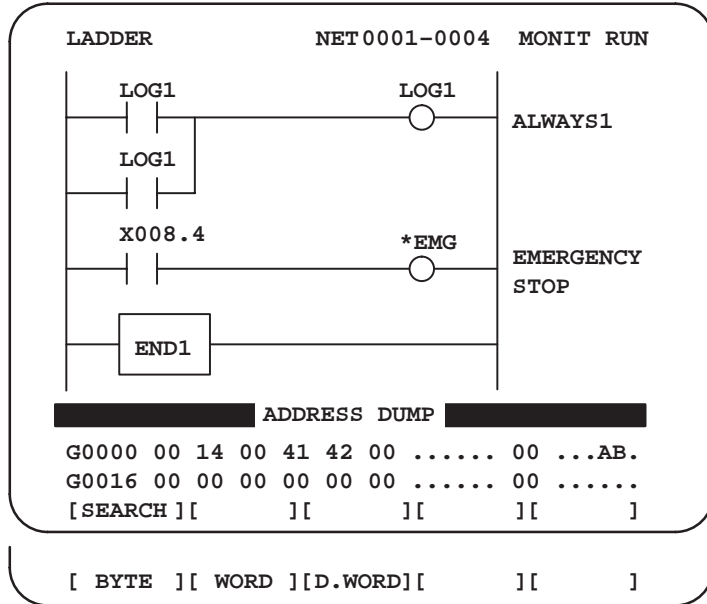

- (a) [SEARCH] : Searches for the display start address.
- (b) [BYTE] : Displays the status in byte format (1 byte).
- (c) [WORD] : Displays the status in word format (2 bytes).
- (d) [D.WORD]: Displays the status in long format (4 bytes).

(3) Parameter display

[DPARA] : Displays the values of functional instruction parameters.

[NDPARA] : Does not display the values of functional instruction parameters.

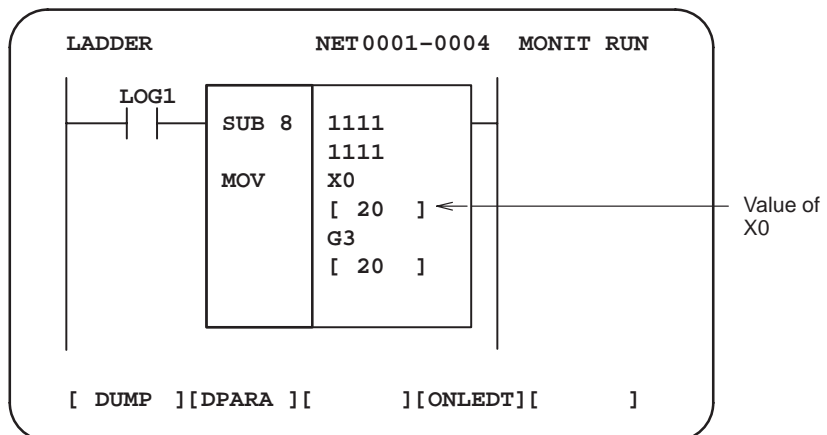

4.4.3 PMCDGN Screen

• TITLE screen

Press soft key [PMCDGN] then PMC's diagnostic screen is displayed.

The title data registered when a ladder program is prepared is displayed.

Page number
↓

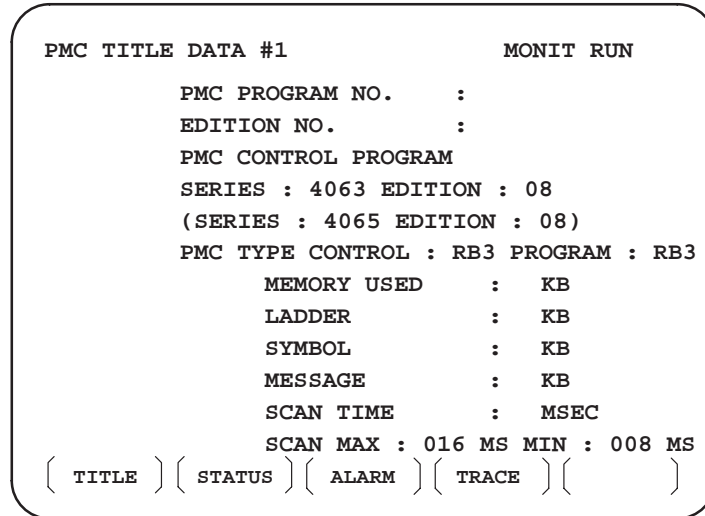

Other soft keys

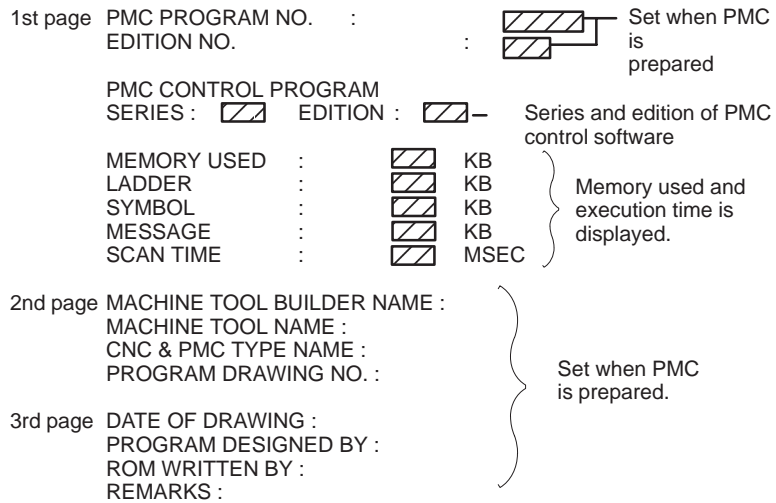

● **STATUS screen**

On/Off state of input/output signals and internal relay is displayed.





PMC SIGNAL STATUS								MONIT RUN
ADDRESS	7	6	5	4	3	2	1	0
	ED7	ED6	ED5	ED4	ED3	ED2	ED1	ED0
G0000	0	0	0	0	1	0	1	0
	ED15	ED14	ED13	ED12	ED11	ED10	ED9	ED8
G0001	0	0	0	0	0	0	0	0
	ESTB	EA6	EA5	EA4	EA3	EA2	EA1	EA0
G0002	0	0	0	0	0	0	0	0
G0003	0	0	0	0	0	0	0	0
	FIN							
G0004	0	0	0	0	0	0	0	0

← Signal name
 ← Signal state
 0: Off
 1: On

 Signal state reverses for signals with *.
 0: On
 1: Off

{ SEARCH } { } { } { } { }

[Search Method]

- Page keys   : Forward and Backward by screen
- Cursor keys   : Forward and Backward by diagnostic number
- To search a specified address or signal name, input an address number or signal name and press [SEARCH].

● **Alarm screen**

Displays an alarm generated in PMC.

PMC ALARM MESSAGE	MONIT RUN
ER32 NO I/O DEVICE	
	ALM

Alarm display
 For details of alarms, refer to Appendix B List of Alarms.

 ← Blinked

{ TITLE } { STATUS } { ALARM } { TRACE } { }

● **TRACE (trace) screen**

The state of the specified signal is stored into trace memory every time the state changes. This function is useful for investigating any intermittent fault. Pressing the [TRACE] key displays the TRACE screen.

● **PMC-NA**

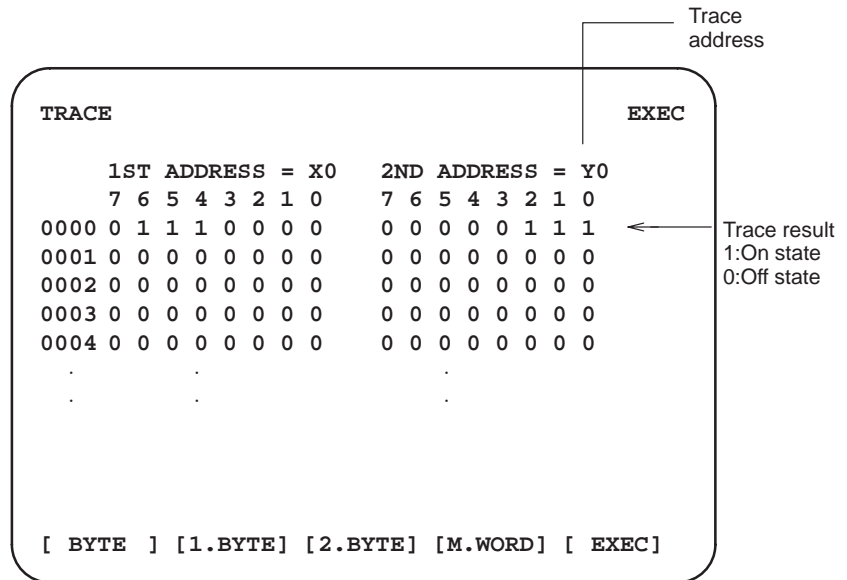

(1) Setting the address

Soft key [BYTE]

Traces eight bits (1-byte setting).

“address” [BYTE] key

Example: “X0” [BYTE] key

Soft keys [1.BYTE] and [2.BYTE]

Traces two addresses which are not consecutive.

“address” [1.BYTE] or [2.BYTE] key

Example: “X0” [1.BYTE] key

“Y0” [2.BYTE] key

Soft key [M.WORD]

A physical address can be specified for a trace. Traces 16 consecutive bits.

“physical-address” [M.WORD] key

Example: “FF9800” [M.WORD] key

(2) Executing a trace

Soft key [EXEC]

Pressing the [EXEC] key starts tracing. Any previous trace results are cleared and tracing is started from the beginning. The trace result is updated only when the signal state is changed. The latest trace results, consisting of 256 bytes, are always stored regardless of how much time has elapsed.

Soft key [STOP]

Pressing the [STOP] key stops tracing. The trace results are maintained.

(3) Displaying the trace results

The latest trace result is indicated by the cursor. The cursor moves on the CRT screen as the trace results are updated.

If the cursor moves off the screen, the latest trace result can be displayed by scrolling the screen using the  cursor key.

● PMC-NB

1. Trace parameter screen

```

PMC SIGNAL TRACE                               MONIT RUN
TRACE MODE      :
(0:1BYTE/1:2BYTE/2:WORD)
1STTRACE ADDRESS CONDITION
ADDRESS TYPE    : (0:PMC/1:PHY)
ADDRESS        :
MASK DATA     :
2NDTRACE ADDRESS CONDITION
ADDRESS TYPE    : (0:PMC/1:PHY)
ADDRESS        :
MASK DATA     :

( T.DISP ) ( EXEC ) (      ) (      ) (      )

```

↑ Changes to a trace memory display screen (Screen on the next page)

Select each item by cursor key

- a. TRACE MODE: Select the trace mode
 - 0=Records changes of 1-byte signals
 - 1=Records changes of independent 2-byte signals
 - 2=Records changes of consecutive 2-byte signals
- b. ADDRESS TYPE:
 - 0=PMC address is used for tracing address.
 - 1=Physical address is used for tracing address.
 - (Mainly used for C-language program)
- c. ADDRESS:Set a tracing address.

d. MASK DATA: The bits to be traced are specified by a hexadecimal number (2 digits).

For example, to trace the signals at bit 7,6,5 and 0, set E1 (hexadecimal) to MASK DATA.

```

#7 #6 #5 #4 #3 #2 #1 #0
E1%  1  1  1  0  0  0  0  1
    
```

However, even if bit 4,3,2 and 1 changes, tracing (memory registration) cannot be done but signal status is memorized when a tracing is executed.

[Correspondence of binary and hexadecimal number]

```

00002 : 016  00012 : 116  00102 : 216  00112 : 316
01002 : 416  01012 : 516  01102 : 616  01112 : 716
10002 : 816  10012 : 916  10102 : A16  10112 : B16
11002 : C16  11012 : D16  11102 : E16  11112 : F16
    
```

2. Trace memory contents display screen

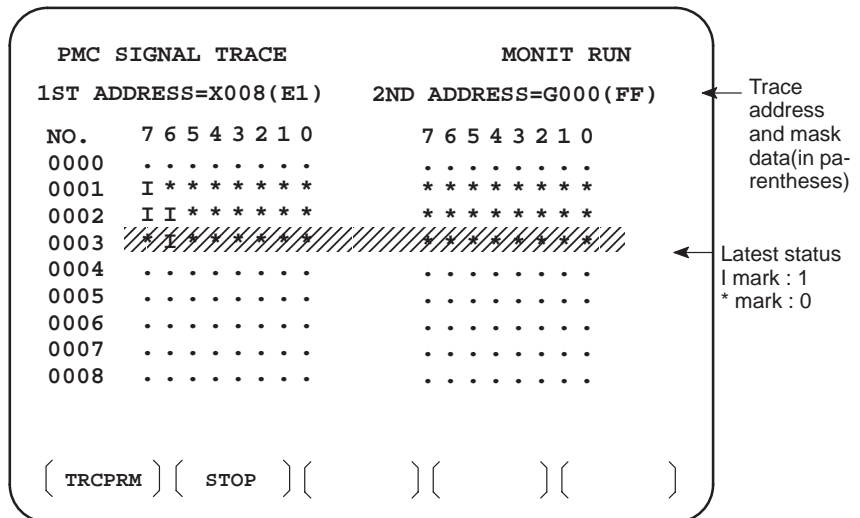

10"LCD/14"CRT is displayed by 1 and 0.

- a. Soft key [TRCPRM]: Return to the trace parameter setting screen (screen of previous page)
- b. Soft key [EXEC]: Starts tracing.
Trace memory is cleared and each time a specified signal changes, its status is recorded. Trace memory is 256 bytes and if tracing is executed 128 times by 2-byte tracing, tracing is executed again from the head of memory.
- c. Soft key [STOP]: Ends the tracing.

*The tracing parameters are held even if the power is turned off.



#5 Tracing starts by [EXEC].
1 : Tracing starts automatically after power on

- **ANALYS screen**

Change of signals is displayed as the same display as that on the oscilloscope.

- **PMC-NB**

1. Parameter setting screen (1st page)

PMC SIGNAL ANALYSIS(PARAM)		MONIT RUN
SAMPLING TIME	: 10 (1-10 SEC)	(a)
TRIGGER ADDRESS	: G0007.2	(b)
CONDITION	: 0 (0: START 1: TRIGGER-ON 2: TRIGGER-OFF)	(c)
TRIGGER MODE	: 0 (0: AFTER 1: ABOUT 2: BEFORE 3: ONLY)	(d)
(SCOPE) (DELETE) (INIT) (ADDRESS) ()		

Select each item by cursor key

- (a) Set a sampling time.
- (b) Specifies an address from which recording of signals is started.
- (c) Set a condition under which recording is initiated.
 - 0 : Started by soft key **[START]**
 - 1 : Started by rise of a trigger signal after you press the soft key **[START]**
 - 2 : Started by fall of a trigger signal after you press the soft key **[START]**
- (d) Set a trigger mode
 - 0 : Record signal status after the trigger condition is satisfied
 - 1 : Record signal status before and after the trigger condition is satisfied.
 - 2 : Record signal status before the trigger condition is satisfied.
 - 3 : Record signal status when the trigger condition is satisfied.
(Display is same as trace memory).

2. Parameter setting screen (2nd page)

PMC SIGNAL ANALYSIS(PARAM)		MONIT RUN
SIGNAL ADDRESS		
1 : X0000.0	9 : Y0000.0	} Up to 16 signals
2 : X0000.1	10 : R0000.1	
3 : X0002.0	11 :	
4 : X0005.0	12 :	
5 :	13 :	
6 :	14 :	
7 :	15 :	
8 :	16 :	
(SCOPE) (DELETE) (INIT) (ADDRESS) ()		

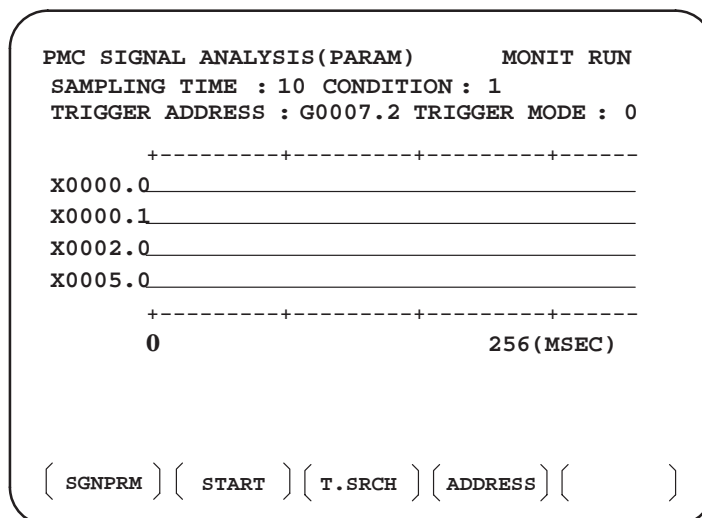

- a. Soft key [SCOPE] : Select signal waveform display screen
- b. Soft key [DELETE] : Delete data on the cursor position
- c. Soft key [INIT] : Initialize parameters of signal waveform display
- d. Soft key [ADDRESS] or [SYMBOL] :
Switch addresses and symbols for display

3. SCOPE screen



The above screen is for a system with graphic display.

I and * are used for display if graphic function is not equipped.

- a. Soft key [SGNPRM] : Returns to parameter screen.
- b. Soft key [START] or [STOP] : Start or stop the record.
(If TRIGGER MODE=3, signal is displayed when you press STOP key.)
- c. Soft key [T.SRCH] : Displayed for a specified time.
- d. Soft key [ADDRESS] or [SYMBOL] : Switch addresses and symbols for display
- e. Soft key [EXCHG] : Change order of signals displayed.
 - Press soft key [EXCHG]
 - Move the cursor to a signal to be changed.
 - Press soft key [SELECT].
 - Move the cursor to the destination.
 - Press [TO] and [EXEC], then the signal changes its order.
- f. Soft key [SCALE]: Changes time scale for graphic display. Scale changes from 256 to 512, and to 1024 msec every time you press the key.
- g. Cursor key   : Scrolls time axis forward and backward

4.4.4 PMCRAM Screen

● **Inputting PMC parameters from the MDI**

- (1) Set to MDI mode or emergency stop state.
- (2) Set PARAMETER WRITE (on setting screen) to 1 or set the program protect signal (KEY4) to 1.

	PWE	KEY4	
Timer counter	○	-	Either one
Keep relay	○	○	
Data table	○	○	Either one

- (3) Press a soft key and select a required screen.
 [TIMER] : Timer screen
 [COUNTR] : Counter screen
 [KEEPRL] : Keep relay screen
 [DATA] : Data table screen
- (4) Press cursor key and move the cursor to a desired number.
- (5) Input a numeric key and press key and data is input.
- (6) After the data is input, set PARAMETER WRITE or KEY4 on setting screen to 0.

● **TIMER screen**

This screen is used for setting timer time of the functional instruction (SUB 3).

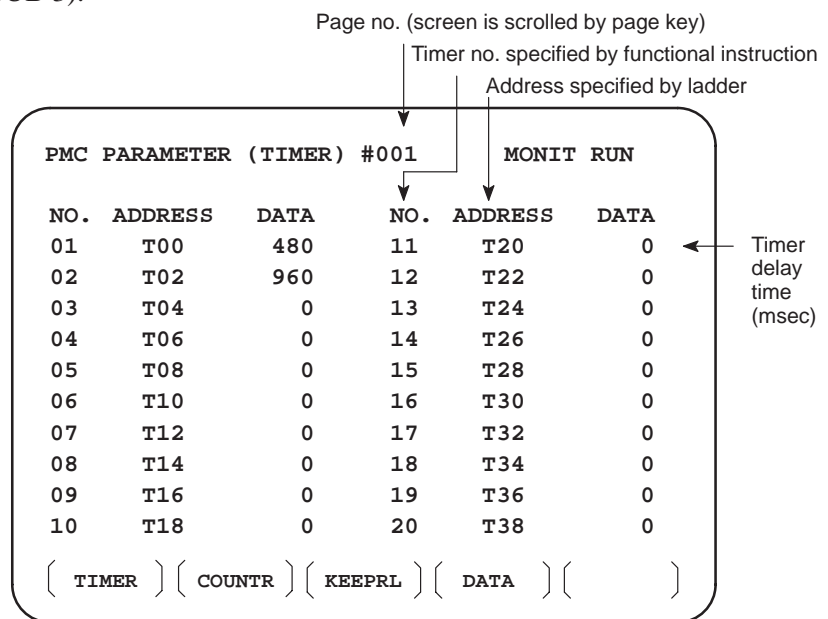

Timer set time : Timer no. 1-8 is max. 1572.8 sec and its accuracy is 48ms.
 Timer no. 9 is max. 262.1 sec and its accuracy is 8ms.

● COUNTER screen

This screen sets and displays max. value of counter and current value of the counter instruction (SUB 4).

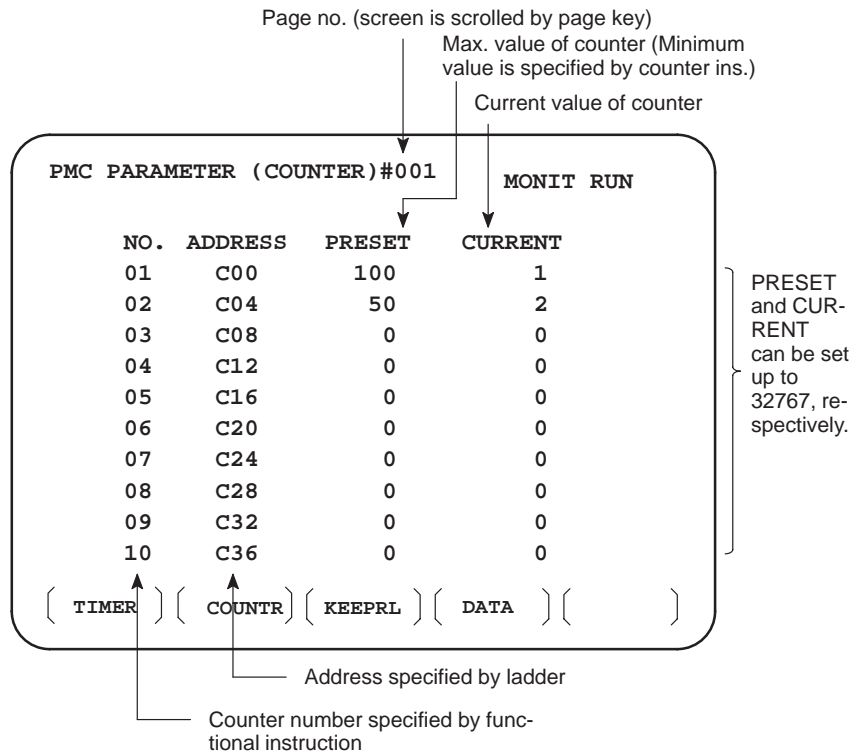

● KEEP RELAY screen

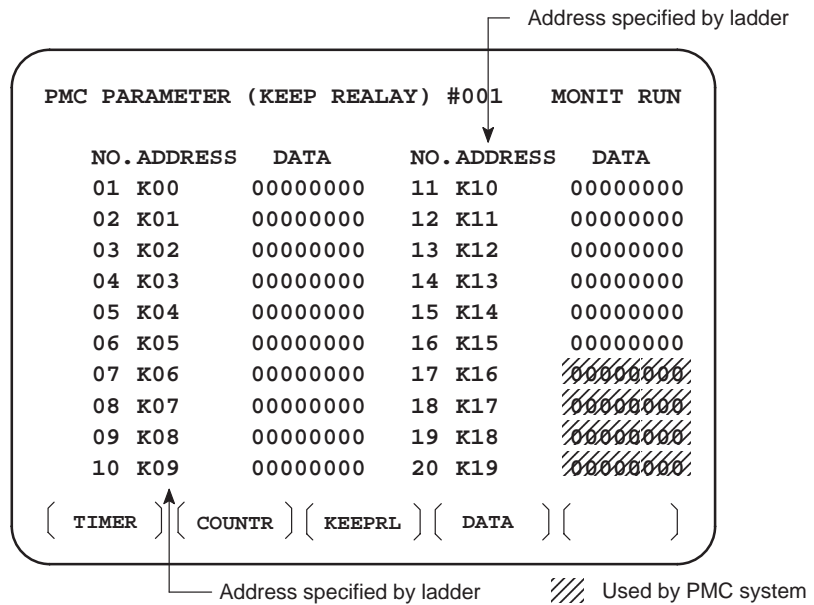

● **PMC-NA**

(1) Nonvolatile memory control

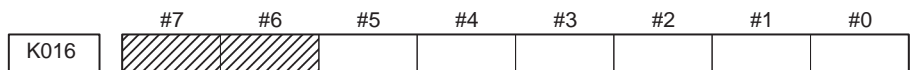

- #7 (**MWRTF2**) Nonvolatile memory writing status
- #6 (**MWRTF1**) Nonvolatile memory writing status

(2) PMC system parameters

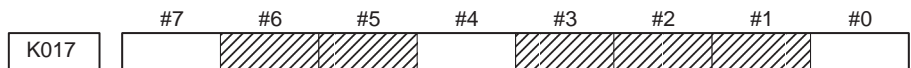

- #6 1 : Writing to flash EEPROM is always checked after a sequence program has been edited.
0 : The I/O screen is used for writing to flash EEPROM after a sequence program has been edited.
- #5 1 : A sequence program is started upon power-on.
0 : A sequence program is executed by pressing the RUN key on the PMC screen.
- #3 1 : The rate of transfer to and from external input/output devices is 9600 bps.
0 : The rate of transfer to and from external input/output devices is 4800 bps.

External input/output devices refer to a FANUC FLOPPY CASSETTE ROM WRITER and FA WRITER. (4800 bps is always selected for a FANUC PRINTER.)
- #2 1 : The rate of transfer to and from FAPT LADDER or FAPT PASCAL is 4800 bps.
0 : The rate of transfer to and from FAPT LADDER or FAPT PASCAL is 9600 bps.
- #1 1 : The contents of PMC data can be initialized.
0 : The contents of PMC data cannot be initialized.

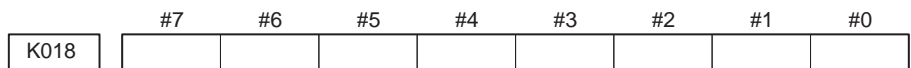

Used by the system. Do not change the setting. Usually set to 0.

● **PMC-NB**

(1) Nonvolatile memory control

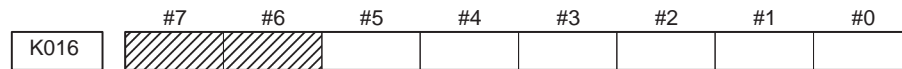

#7 (MWRTF2) Writing status in nonvolatile memory

#6 (MWRTF1) Writing status in nonvolatile memory

(2) PMC system parameter

The following keep relays are used by the system, therefore they cannot be used in the sequence program.



#6 ANASTAT 0 : Pressing [EXEC] key initiates sampling by signal waveform display function.

1 : Turning power to on initiates sampling by signal waveform display function.

#5 TRCSTAT 0 : Signal tracing starts by soft key [EXEC] in signal trace function.

1 : Signal tracing starts automatically by power on in signal trace function.

#4 MEMINP 0 : Data input cannot be done in memory contents display function.

1 : Data input can be done in memory contents display function.

#2 AUTORUN 0 : A sequence program is executed automatically after the power is turned on.

1 : A sequence program is executed by sequence program soft key.

#1 PRGRAM 0 : Built-in programmer is not used.

1 : Built-in programmer is used.

#0 LADMASK 0 : Dynamic display of ladder is executed.

1 : Dynamic display of ladder is not executed.

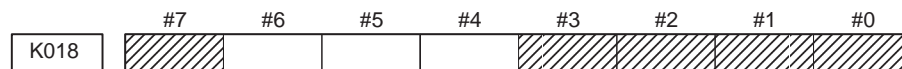

#7 IGDINT 0 : When the screen is switched to the PCMMDI screen, the CRT is initialized.

1 : When the screen is switched to the PCMMDI screen, the CRT is not initialized.

* This flag is used to control whether the PMC management software initializes the CRT when switching to the PCMMDI screen from another screen is performed. When this flag is set to on, the CRT must be initialized using the application.

#3 TRNSRAM 0 : A ladder program is not automatically sent to the backup RAM after on-line editing is completed.

1 : A ladder program is automatically sent to the backup RAM after on-line editing is completed.

#2 TRGSTAT 0 : The trigger stop function does not automatically start when the power is turned on.

1 : The trigger stop function automatically starts when the power is turned on.

- #1 DBGSTAT** 0: In the C language debug function, the automatic break processing does not start when the power is turned on.
 1 : In the C language debug function, the automatic break processing starts when the power is turned on.
- #0 IGNKEY** 0 : Function keys are enabled when a user program displays the user screen.
 1 : Function keys are disabled when a user program displays the user screen.
 * When this bit is set to 1 of the user screen, the screen cannot be switch to the NC screen using function keys. A program which always sets this bit to 0 or which changes the screen to the NC screen is required.



These bits are status of not used for PMC management software are used by system. Do not change the values. Usually all the bits are 0.

• **DATA (data table) screen**

A data table is displayed according to the parameters specified for the control data.

DATA TABLE CONTROL DATA			
NO.	ADDRESS	PARAMETER	NO.OF DATA
000	D0000		3
001	D0002	00000000	20
001	D0010	00000010	20
001	D0018	00001000	50

DATA TABLE DATA #001		
NO.	ADDRESS	DATA
0000	D0026	20
0001	D0027	30
0002	D0028	40
.	.	.
.	.	.
.	.	.
0019	D0045	99

● **PMC-NA**

(1) Control data table

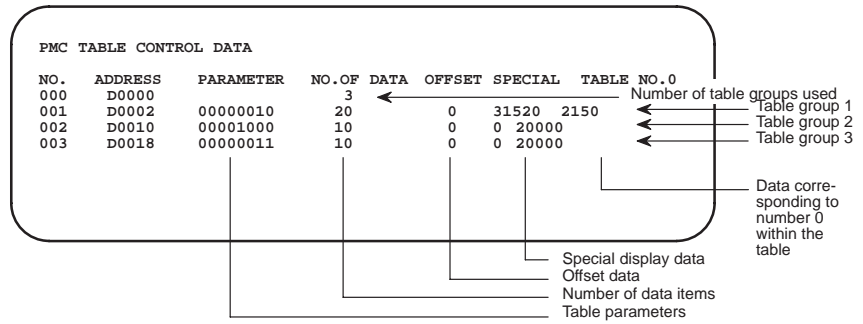

a) Parameter format



- #7** 1 : The data table is used for teaching data.
0 : The data table is not used for teaching data.
- #6** 1 : The contents of the data table cannot be modified from the MDI.
0 : The contents of the data table can be modified from the MDI.
- #3** 1 : The data length for the data table is 4 bytes.
0 : The data length for the data table is 1 or 2 bytes.
- #2** 1 : When the contents of the data table are modified from the MDI, the same data cannot be entered.
0 : When the contents of the data table are modified from the MDI, the same data can be entered.
- #1** 1 : The data length for the data table is 2 bytes.
0 : The data length for the data table is 1 byte.
- #0** 1 : The data format for the data table is BCD.
0 : The data format for the data table is binary.

Point
The correspondence between the data length and the settings of bits 3 and 1 is as follows:

#3	#1	Data length
1	1	4 bytes
1	0	
0	1	2 bytes
0	0	1 byte

(2) Data table

DATA TABLE DATA #001 ← Data table group number		
NO.	ADDRESS	DATA
0000	D0026	20
0001	D0027	30
0002	D0028	40
.	.	.
.	.	.
0019	D0045	99

● PMC-NB

(1) Data table setting screen

PMC DATA TBL CONTROL #001 MONIT RUN

GROUP TABLE COUNT = 2 ← No. of data table groups

NO.	ADDRESS	PARAMETER	TYPE	NO.OF DATA
001	D0000	00000000	0	10
002	D0020	00000011	1	20
003				
004				
005				
006				
007				
008				

{ G.DATA } { G.CONT } { NO.SRH } { } { INIT }

No. of screen

No. of data table groups

No. of data table

Data length

Table parameter

Data table head address

Group no. of data table

- a. Soft key [G.DATA] : Select data display screen of data table. (Next screen)
- b. [G.CONT]: Set the no. of groups of data table.
- c. [NO.SRH]: Move the cursor to a specified group.
- d. Soft key [INIT]: Initializes the setting of data table.
 No. of groups is 1, ADDRESS is D0000, PARAMETER is 0000000, TYPE is 0, NO. OF DATA is 1860.

* This operation is done usually when a sequence program is prepared. When PMC parameters are set, internal parameters are not affected.

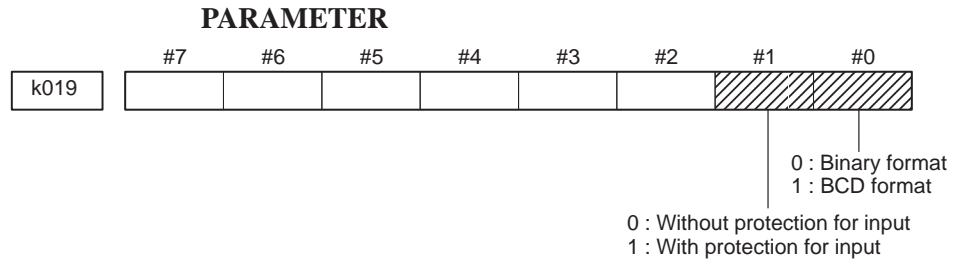

TYPE

0 : 1-byte length 1 : 2-byte length 2 : 4-byte length

- e. Using the page key, next screen/previous screen can be selected.
(Only when the screen page number is displayed)

(2) Data display screen

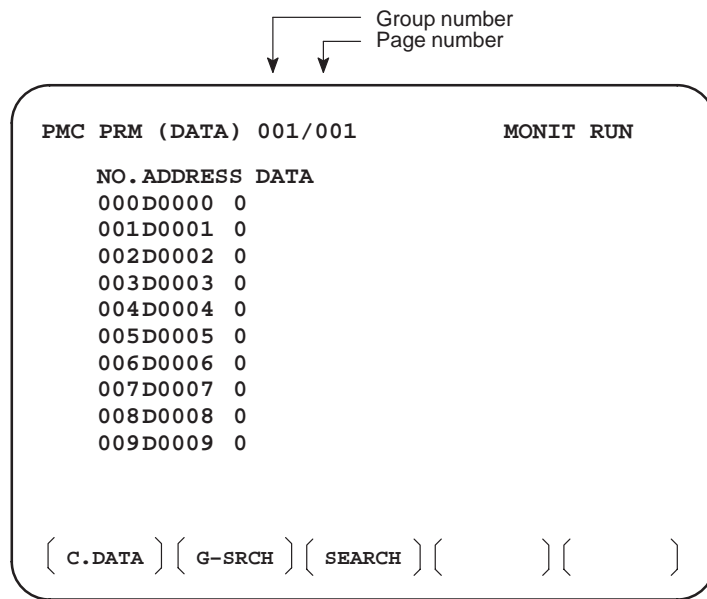

- a. Soft key [C.DATA] :Returns to the data table setting screen. (Screen in item (1))
- b. [G-SRCH] : Head of the specified group is selected.
- c. [SEARCH]: Searches an address in a group currently selected.

4.5 SIGNAL AND SYMBOL CORRESPONDENCE TABLE

	Symbol	Signal name	PMC address		
			For M series and T series	For TT series	
				HEAD#1	HEAD#2
A	ABS	Absolute Selection Signal	G004.5	G099.5	
	*ACTF1 to 10	Axis selection signal in actual speed display	G067.4, G071.4 to G103.4	G131.4, G135.4 to G167.4	
	AE1 to 3	Measuring position reached signals	G001.2 to 4	G001.2 to 4	G049.2 to 4
	AF1X0 to 7	Miscellaneous function BCD code signals (PMC axis control)	F141	F103	
	AF2X0 to 7	Miscellaneous function BCD code signals (PMC axis control)	F142	F104	
	AF3X0 to 7	Miscellaneous function BCD code signals (PMC axis control)	F143	F105	
	AFL	Auxiliary Function Lock Signal	G004.0	G099.0	
	*AFV0 to 7	Second Feedrate Override	G013.0 to 7	G013.0 to 7	G061.0 to 7
	AGJ	Manual arbitrary angle feed selection signal	G003.7	G097.7	
	*AIT	Automatic operation all-axis interlock signal	G001.0	G001.0	G049.0
	AJA0 to 7	Manual arbitrary angle feed direction selection signals	G017.0 to 7	G123.0 to 7	
	AJA8 to 12	Manual arbitrary angle feed direction selection signals	G016.0 to 4	G122.0 to 4	
	AJP1A to D, AJP2A to D AJSTB	Manual arbitrary angle feed axis selection signal Manual arbitrary angle feed direction selection signals	G018.0 to 3 G018.4 to 7 G016.7	G124.0 to 3 G124.4 to 7 G122.7	
	+AJ, -AJ	Manual arbitrary angle feed signals	G016.5, G016.6	G122.5, G122.6	
	AL	Alarm signal	F000.1	F096.1	
	ALMA	Serial spindle interface status signal (1st spindle)	F229.0	F229.0	
	ALMB	Serial spindle interface status signal (2nd spindle)	F245.0	F245.0	
	ALNGH	Signal for executing handle feed in the direction of the tool axis	G156.0		

	Symbol	Signal name	PMC address		
			For M series and T series	For TT series	
				HEAD#1	HEAD#2
A	*APF00 to 15	Second Feedrate Override B	G146 to G147		
	AR0 to AR15	Actual Spindle Speed Signal	F012 to F013	F008 to F009	F056 to F057
	ARSTA	Alarm Reset Signal	G226.0	G226.0	
	ARSTB	Alarm Reset Signal	G234.0	G234.0	
	AXC1,2,4	Axis interchange signals	G041.0 to 2		
B	B0 to B31	Second Auxiliary Function Code Signal	F028 to F031	F028 to F031	F076 to F079
	BATL	Low battery voltage alarm signal	F040.7	F120.7	
	BCAN	Block Cancel Signal	G157.6		
	BCLP	B-axis clamp signal	F007.1		
	BDT1 to 9	Optional Block Skip Signal	G004.2 G007.0 to 7	G004.2 G007.0 to 7	G052.2 G055.0 to 7
	BDT10	Optional block skip signal of software operator's panel	F130.2		
	*BECLP	B-axis clamp completion signal	G019.7		
	*BEUCL	B-axis unclamp completion signal	G019.6		
	BF	Second Auxiliary Function Strobe Signal	F008.3	F004.3	F052.3
	BFIN	Second Auxiliary Function End Signal	G046.3	G006.3	G054.3
	BGEDT	Background editing state output signal	F043.3	F120.4	
	BRN	Block Restart Selection Signal	G002.6		
	*BSL	Block start interlock signal	G001.1	G001.1	G049.1
	BUCLP	B-axis unclamp signal	F007.0		
	BUF1 to 10	Buffer full signal (PMC axis control)	F066.5, F070.5 to F102.0	F130.5, F134.5 to F166.5	
C	CD1X0 to 7 CD2X0 to 7 to CD10X0 to 7	Axis control command code signals (PMC axis control)	G385 G393 to G457	G385 G393 to G457	
	CDV0 to 7	Cutting depth override signals	G027		
	*CHF	Chamfering Signal	G008.0	G008.0	G056.0
	*CHLD	Chopping hold signal	G044.7		
	*CHP0	Chopping speed override signal	G044.0		

	Symbol	Signal name	PMC address		
			For M series and T series	For TT series	
				HEAD#1	HEAD#2
C	*CHP2	Chopping speed override signal	G044.1		
	*CHP4	Chopping speed override signal	G044.2		
	*CHP8	Chopping speed override signal	G044.3		
	CNCA1 to 10	Axis control command read completion signal (PMC axis control)	F066.7, F070.7 to F102.7	F130.7, F134.7 to F166.7	
	CNGTL	Signal for changing the tool length compensation in the direction of the tool axis with the handle	G156.3		
	*CSL	Cutting block start interlock signal	G000.1	G000.1	G048.1
	*CSMZ	In-position Check Signal	G008.1	G008.1	G056.1
	CSS	Constant surface speed signal	G001.7	F000.7	F048.7
	CTH1A	Clutch/Gear Signal (1st spindle)	G227.3	G227.3	
	CTH1B	Clutch/Gear Signal (2nd spindle)	G235.3	G235.3	
	CTH2A	Clutch/Gear Signal (1st spindle)	G227.2	G227.2	
	CTH2B	Clutch/Gear Signal (2nd spindle)	G235.2	G235.2	
D	D	Manual data input selection signal	G003.3	G097.3	
	*DEC1 to 10	Reference Point Return Deceleration Signals	G064.5, G068.5 to G100.5	G128.5, G132.5 to G100.5	
	DEN	Distribution End Signal	F001.0	F000.0	F048.0
	DEN1 to 10	Distribution completion signal (PMC axis control)	F066.6, F070.6 to F102.6	F130.6, F134.6 to F166.6	
	DIST0 to 23	Incremental feed distance selection signals	G021 to G023	G107 to G109	
	DIST24 to 26	Incremental feed distance selection signals	G020.0 to 2	G106.0 to 2	
	DLK	Display Lock Signal	G004.6	G099.6	
	DM00	Decode M Signal	F009.4	F005.4	F053.4
	DM01	Decode M Signal	F009.5	F005.5	F053.5
	DM02	Decode M Signal	F009.6	F005.6	F053.6
	DM30	Decode M Signal	F009.7	F005.7	F053.7
	DRNO	Dry run signal of software operator's panel	F130.1		
	DRN	Dry Run Signal	G004.1	G099.1	

	Symbol	Signal name	PMC address		
			For M series and T series	For TT series	
				HEAD#1	HEAD#2
D	DT1X0 to 31 DT2X0 to 31 to DT10X0 to 31	Axis control data signals (PMC axis control)	G388 to G391 G396 to G399 to G460 to G463	G388 to G391 G396 to G399 to G460 to G463	
	DTCH1 to 10	Cancel controlled axis signals	G064.7, G068.7 to G100.7	G128.7, G132.7 to G164.7	
	DVAL	Velocity control servo alarm ignore signal	G026.1	G110.7	
E	*+/-ED1 to 10	External deceleration signals	G064.2, G064.3 G068.2, G068.3 to G100.2, G100.3	G128.2, G128.3 G132.2, G132.3 to G164.2, G164.3	
	EDT	Tape storage and edit selection signal	G003.6	G097.6	
	EDT0	Tape storage and edit selection signal of software operator's panel	F129.6		
	EF	External Operation Signal	F008.4	F004.4	F052.4
	EGBM1 to 10	EGB mode confirm signal	F066.3, F070.3 to F102.3		
	EIA0 to EIA7	Address signals for external data input	G033	G113	
	EID0 to EID47	Data signals for external data input	G034 to G039	G114 to G119	
	EIHEAD	Tool post specification signal for external data input		G112.4	
	EIREND	Read end signal for external data input	F032.5	G112.5	
	EISTB	Strobe signal for external data input	G032.7	G112.7	
	EOA0 to EOA7	Address signals for external data output	F033	F113	
	EOD0 to EOD47	Data signals for external data output	F034 to F039	F114 to F119	
	EOHEAD	Tool post specification signal for external data output		F112.4	
	EOREND	Read end signal for external data output	G032.5	G112.5	
	EOSTB	Strobe signal for external data output	F032.7	F112.7	
	ERDRQ	External data output request signal	G032.6	G112.6	
	ERS	External reset signal	G000.7	G096.7	
	ESEND	External search end signal	F007.5	F003.5	F051.5
	*ESP	Emergency stop signal	G000.4, X006.4	G096.4, X006.4	
	*ESPA	Emergency Stop Signal	G226.1	G226.1	

	Symbol	Signal name	PMC address		
			For M series and T series	For TT series	
				HEAD#1	HEAD#2
E	*ESPB	Emergency Stop Signal	G234.1	G234.1	
	EUI00 to 15	P-code macro input signals	G144.0 to G145.7		
	EUO00 to 15	P-code macro output signals	F166.0 to F167.7		
	EXPUN	External punch start signal	G032.0	G112.0	
	EXRD	External read start signal	G032.1	G112.1	
	EXSTP	External read/punch stop signal	G032.2	G112.2	
F	F1D	F1 Digit Selection Signal	G005.3		
	FD1X0 to 15 FD2X0 to 15 to FD10X0 to 15	Feedrate specification signals (PMC axis control)	G386 to G387 G386 to G387 to G458 to G459	G386 to G387 G394 to G395 to G458 to G459	
	FFIN	Canned Cycle Auxiliary Signal End Signal	G005.2	G005.2	G053.2
	FIN	End Signal	G005.1	G005.1	G053.1
	FIN1X	Miscellaneous function completion signal (PMC axis control)	G046.4	G110.4	
	FIN2X	Miscellaneous function completion signal (PMC axis control)	G046.5	G110.5	
	FIN3X	Miscellaneous function completion signal (PMC axis control)	G046.6	G110.6	
	FMF	Canned Cycle Auxiliary Signal Read-out Signal	F008.5	F004.5	F052.5
	FRP1 to 10	Floating Reference Point Return End Signals	F065.5, F069.5 to G101.5	F129.5, F133.5 to F165.5	
	*FV00 to *FV70	Feedrate override signals of software operator's panel	F133		
	*FV0 to 7	Feedrate Override	G012.0 to 7	G012.0 to 7	G060.0 to 7
G	GOQSM	Signal for selecting the mode for writing tool compensation	G028.7	G028.7	G076.7
	GS1	Spindle Gear Selection Signal	G026.4	G026.4	
	GS2	Spindle Gear Selection Signal	G026.5	G026.5	
	GS4	Spindle Gear Selection Signal	G026.6	G026.6	

	Symbol	Signal name	PMC address		
			For M series and T series	For TT series	
				HEAD#1	HEAD#2
H	H	Manual handle feed selection signal	G003.1	G097.1	
	HD00 to 2 HD03 HD04 to 6	Signals for outputting the states of the high-speed skip signal and the high-speed measuring position reach signal	F047.0 to 2 F047.3 F047.4 to 6	F107.0 to 2 F107.4 to 6	
	HO	Manual handle feed selection signal of software operator's panel	F129.1		
	HS1A to D	Manual handle feed axis selection signal	G011.0 to 3	G103.0 to 3	
	HS2A to D		G011.4 to 7	G103.4 to 7	
	HS3A to D		G010.0 to 3	G102.0 to 3	
	HS1A0 to HS1D0	Manual handle feed axis selection signals of software operator's panel	F131.0 to 3		
I	IBATL	Low voltage alarm signal for RAM_FILE battery	F045.6	F120.6	
	IHEAD1	Signal for selecting a tool post in the memory mode	G110.0		
	IHEAD2	Signal for selecting a tool post in the memory mode	G110.1		
	IMGY	Signal for selecting the virtual axis control mode	G157.3		
	INCH	Inch input signal	F001.3	F097.3	
	INDXA	Spindle Orientation Stop Position Change Command (1st spindle)	G229.0	G229.0	
	INDXB	Spindle Orientation Stop Position Change Command (2nd spindle)	G237.0	G237.0	
	INP1 to 10	Position signals	F064.6, F068.6 to F100.6	F128.6, F132.6 to F164.6	
	INTGA,B	Velocity integrating control signals	G226.5, G234.5	G226.5, G234.5	
	IPEN	Distribution End Signal	F001.1	F000.1	F048.1
	*IT	All-axis interlock signal	G000.0	G096.0	
	*IT1 to 10	Axis interlock signals	G064.4, G068.4 to G100.4	G128.4, G132.4 to G164.4	
J	J	Jog feed selection signal	G003.2	G097.2	
	+/-J1 to 10	Feed axis and direction selection signal	G065.0, G065.1 to G101.0, G101.1	G129.0, G129.1 to G165.0, G165.1	

	Symbol	Signal name	PMC address		
			For M series and T series	For TT series	
				HEAD#1	HEAD#2
J	+/- J10 to +/- J40 +/- J50 to +/- J60	Feed axis and direction selection signals of software operator's panel	F136.0 to F136.7 F138.0 to F138.3		
	JO	Manual continuous feed selection signal of software operator's panel	F129.2		
	*JV00 to *JV150	Manual feedrate override signals of software operator's panel	F134 to F135		
	*JV0 to 15	Manual feedrate override signals	G014 to G015	G104 to G105	
K	KEY1 to 4	Memory protection keys	G005.4 to 7	G100.4 to 7	
	KEY0	Memory protection key of software operator's panel	F131.4		
L	*+/-L1 to 10	Overrun signals	G064.0, G064.1 to G100.0, G100.1	G128.0, G128.1 to G164.0, G164.1	
	LDT1A	Load Detect Signal 1 (1st spindle)	F229.4	F229.4	
	LDT1B	Load Detect Signal 1 (2nd spindle)	F245.4	F245.4	
	LDT2A	Load Detect Signal 2 (1st spindle)	F229.5	F229.5	
	LDT2B	Load Detect Signal 2 (2nd spindle)	F245.5	F245.5	
M	M0 to M31	Miscellaneous Function Code Signal	F016 to F019	F016 to F019 F064 to F067	
	M200 to M215	Miscellaneous Function Code Signal	F144 to F145		
	M300 to M315	Miscellaneous Function Code Signal	F146 to F147		
	M400 to M415	Miscellaneous Function Code Signal	F148 to F149		
	M500 to M515	Miscellaneous Function Code Signal	F150 to F151		
	MA	Control unit ready signal	F000.7	F096.7	
	MABS	Absolute Selection Check Signal	F004.5	F100.5	
	MAFL	Auxiliary Function Lock Check Signal	F004.0	F100.0	
	MAGJ	Manual arbitrary angle feed selection check signal	F003.7	F099.7	
	MBCAN	Block Cancel Check Signal	G157.4		
	MBDT1	Optional Block Skip Check Signal	F004.2	F001.2	F049.2
	MBDT2 to 9	Optional Block Skip Check Signal	F005.0 to 7	F002.0 to 7	F050.0 to 7
	MD	Manual data input selection check signal	F003.3	F099.3	
	MD1 to 10	Signals indicating direction of movement	F064.3, F068.3 to F100.3	F128.3, F132.3 to F164.3	

	Symbol	Signal name	PMC address		
			For M series and T series	For TT series	
				HEAD#1	HEAD#2
M	MDIO	Manual data input selection signal of software operator's panel	F129.3		
	MDLK	Display Lock Check Signal	F004.6	F100.6	
	MDRN	Dry Run Check Signal	F004.1	F100.1	
	MDTCH1 to 10	Controlled axis canceled signals	F064.7, F068.7 to F100.7	F128.7, F132.7 to F164.7	
	MEDT	Tape storage and edit selection check signal	F003.6	F099.6	
	MEM	Memory mode selection	G003.5	G097.5	
	MEMO	Memory mode selection signal of software operator's panel	F129.5		
	MF	Miscellaneous Function Strobe Signal	F008.0	F004.0	F052.0
	MF1X	Miscellaneous function read signal (PMC axis control)	F046.0	F106.0	
	MF2 to 5	Miscellaneous Function Strobe Signal (2nd)	F045.1 to 4		
	MF2X, MF3X	Miscellaneous function read signal (PMC axis control)	F046.1 to 2	F106.1	
	MFIN	Miscellaneous Function End Signal	G046.0	G006.0	G054.0
	MFIN2 to 5	Miscellaneous Function End Signal (2nd and 5th)	G047.1 to 4		
	MH	Manual handle feed selection check signal	F003.1	F099.1	
	MI1 to 10	Mirror image signals	G065.2, G069.2 to G101.2	G129.2, G133.2 to G165.2	
	MIFIN	Manual intervention compensation finish signal	F046.3	F012.5	F060.5
	MIGET	Manual intervention compensation request signal	G046.7	G008.3	G056.3
	+/-MIT1 to 3	Manual feed interlock signals for each axis	G066.0, G066.1 G070.0, G070.1 G074.0, G074.1	G130.0, G130.1 G134.0, G134.1 G138.0, G138.1	
	+/-MIT4 to 10	Manual feed interlock signals for each axis		G142.0, G146.0 to G166.0 G142.1, G146.1 to G166.1	
	MJ	Manual continuous feed selection check signal	F003.2	F099.2	
	MLK	All Axis Machine Lock Signal	G004.7	G099.7	
	MLK1 to 10	Machine Lock Signals	G065.3, G069.3 to G101.3	G129.3, G133.3 to G165.3	

	Symbol	Signal name	PMC address		
			For M series and T series	For TT series	
				HEAD#1	HEAD#2
M	MLKO	Machine lock signal of software operator's panel	F130.7		
	MMEM	Memory mode selection check signal	F003.5		F099.5
	MMI1 to 10	Mirror image check signals	F065.0, F069.0 to F101.0		F129.0, F133.0 to F165.0
	MMLK	All Axis Machine Lock Check Signal	F004.7		F100.7
	MMLK1 to 10	Machine Lock Check Signals	F065.1, F069.1 to F101.1		F129.1, F133.1 to F165.1
	MMOVL	Simultaneous auto/manual operation selection check signal	F002.4		F098.4
	MOVL	Simultaneous auto/manual operation selection Automatic/manual simultaneous operation selection signal	G002.4		G098.4
	MP1,2,4	Manual handle feed distance selection signal	G006.2 to 4		G101.2 to 4
	MP10, 20, 40	Manual handle feed distance selection signals of software operator's panel	F132.2 to 4		
	MR0 to 15	Maximum Spindle Speed Signal	F014 to F015		F010 to F011 F058 to F059
	MRDYA	Machine Ready Signal (1st spindle)	G227.7		G227.7
	MRDYB	Machine Ready Signal (2nd spindle)	G235.7		G235.7
	MS	Incremental feed selection check signal	F003.0		F099.0
	MSBK	Single Block Check Signal	F004.3		F100.3
	MSBK1 to 10	Block stop inhibit signal (PMC axis control)	G384.7, G392.7 to G456.7		G384.7, G392.7 to G456.7
	MSCNTR1 to 10	Spindle contour Control Mode Switch Verify Signal (1st spindle)	F067.7, F071.7 to F103.7		F131.7, F135.7 to F167.7
	MSPPHS	Spindle phase synchronization completion signal	F046.7		F111.7
	MSPSYC	Spindle speed synchronization completion signal	F046.6		F111.6
	MT	Tape mode selection check signal	F003.4		
	MTCHIN	Teach-in selection check signal	F002.3		
MV1 to 10	Signals indicating movement	F064.2, F068.2 to F100.2		F128.2, F132.2 to F164.2	
MZRN	Manual Reference Point Return Selection Check Signal	F002.7		F098.7	

	Symbol	Signal name	PMC address		
			For M series and T series	For TT series	
				HEAD#1	HEAD#2
N	NOT3DM	Signal that specifies whether the manual interruption function for three-dimensional coordinate conversion	G157.7		
	NRROA, B	Signals for executing a shortcut rotation when the stop position in spindle orientation is changed (1st spindle)	G229.2, G237.2	G229.2, G237.2	
O	OFN0 to OFN5	Tool compensation number input signals	G028	G028	G076
	OHALM	Alarm classification signal	F006.2	F101.2	
	OMEPA	Override playback signal	G010.6		
	OME	Override storage signal	G010.5		
	OP	Cycle Operating Signal	F000.5	F096.5	
	OPU0 to OPU7	General-purpose signals of software operator's panel	F137		
	ORARA, B	Orientation Complete Signal	F229.7, F245.7	F229.7, F245.7	
	ORCMA, B	Spindle Orientation Command	G227.6, G235.6	G227.6, G235.6	
	OTALM	Alarm classification signal	F006.3	F101.3	
	OV1X0 to 7 OV2X0 to 7 to OV10X0 to 7	Override signal for each axis in PMC axis control	G368 G369 to G377	G368 G369 to G377	
	OVA0 to 7	Override signals for PMC axis control in the simultaneous start mode	G383	G383	
	OVC	Override Cancel	G004.4	G004.4	G052.4
P	PBATL	Low voltage alarm signal for the absolute position detector battery	F040.6	F120.1	
	PBATZ	Zero voltage alarm signal for the absolute position detector battery	F040.5	F120.2	
	PCAX1 to 10	PMC axis control signal	G066.3, G070.3 to G102.3	G130.3, G134.3 to G166.3	
	PK1 to 10	Parking signal	G065.4, G069.4 to G101.4		
	PMCA1 to 10	Axis control command read strobe signal (PMC axis control)	G066.7, G070.7 to G102.7	G130.7, G134.7 to G166.7	
	PRC	Measuring position record signal	G008.5	G101.0	
	PRTSF	Required parts count arrival signal	F043.6	F012.6	F060.6
	PSALM	Alarm classification signal	F006.0	F101.0	
	PSW01 to 10	Position switch output signal	F165.0, F165.1 to F164.1	F193.0, F193.1 to F192.1	

	Symbol	Signal name	PMC address		
			For M series and T series	For TT series	
				HEAD#1	HEAD#2
R	RAST1 to 10	Reference Point Auto Setting Signal	G067.2, G071.2 to G103.2	G131.2, G135.2 to G167.2	
	RCFNA, B	Switching completion signals	F228.3, F244.3	F228.3, F244.3	
	RCHA, B	Power line status check signals	G226.7, G234.7	G226.7, G234.7	
	RCHPA, B	Power line switching signals	F228.2, F244.2	F228.2, F244.2	
	RGHTH	Signal for executing handle feed perpendicular to the tool axis	G156.1		
	RI0 to 12	Spindle Motor Command Voltage Signal	G024 to G025	G024 to G025	G072 to G073
	RISGN	Spindle Motor Command Voltage Signal	G024.7	G24.7	G072.7
	RMTI0 to 7	Remote buffer input signal	G152.0 to 7		
	RMTO0 to 7	Remote buffer output signal	F152.0 to 7		
	RNDH	Signal for rotating the tool around the center of the tool tip with the handle	G156.2		
	RO0 to RO15	Command Spindle Speed Signal	F010 to F011	F006 to F007	F054 to F055
	ROTAA, B	Rotation Direction Command at Changing Spindle Orientation Stop	G229.1, G237.1	G229.1, G237.1	
	ROV1	Rapid Traverse Override	G006.5	G101.5	
	ROV10 to 20	Rapid traverse override signals of software operator's panel	F132.5 to 6		
	ROV2	Rapid Traverse Override	G006.6	G101.6	
	RPBSY	Read/punch busy signal	F007.4	F102.4	
	RPD	Rapid traverse signal	F001.5	F000.5	F048.5
	RRW	Reset and rewind signal	G000.6	G096.6	
	RSLA, B	Switching request signals	G226.6, G234.6	G226.6, G234.6	
	RSPC	Spindle constant speed signal (Rigid tapping)	F155.2		
	RSPM	Spindle rotation direction signal (Rigid tapping)	F155.1		
	RSPPP	Spindle rotation direction signal (Rigid tapping)	F155.0		
	RST	Reset signal	F000.2	F096.2	
	RST1 to 10	Reset signal (PMC axis control)	G066.6, G070.6 to G102.6	G130.6, G134.6 to G166.6	

	Symbol	Signal name	PMC address		
			For M series and T series	For TT series	
				HEAD#1	HEAD#2
R	RT	Manual rapid traverse selection signal	G006.7	G101.7	
	RTAP	Rigid tapping signal	F040.4		
	RTO	software operator's panel			
	RTO	Manual rapid traverse selection signal of	F132.7		
	RTRCT	Retract signal	G042.4		
	RTRCTF	Retract completion signal	F041.4		
	*RV0B to 6B	Rapid Traverse Override 1 %	G040.0 to 6	G120.0 to 6	
	RVSL	Retrace-in-progress signal	F044.2		
	RVS	Retrace signal	G029.4		
	RWD	Rewind signal	F000.0	F096.0	
S	S	Incremental feed selection signal	G003.0	G097.0	
	S0 to 31	Spindle Speed Function Code Signal	F020 to F023	F020 to F023 F068 to F071	
	SA	Servo ready signal	F000.6	F096.6	
	SARA	Speed Reach Signal (1st spindle)	F229.3	F229.3	
	SARB	Speed Reach Signal (2nd spindle)	F245.3	F245.3	
	SBK1 to 10	Block stop signals (PMC axis control)	G066.4, G070.4 to G102.4	G130.4, G134.4 to G166.4	
	SBKO	Single block signal of software operator's panel	F130.3		
	SBK	Single Block	G004.3	G099.3	
	SCLP	Spindle Clamp Signal	F042.1	F123.1	
	SCNTR1 to 10	Spindle Contour Control Mode Switch Signals	G067.7, G071.7 to G103.7	G131.7, G135.7 to G167.7	
	SDTA	Speed Detect Signal	F229.2	F229.2	
	SDTB	Speed Detect Signal	F245.2	F245.2	
	*SECLP	Spindle Clamp Completion Signal	G026.3	G026.3	
	*SEUCL	Spindle Unclamp Completion Signal	G026.2	G026.2	
	SF	Spindle Speed Function Strobe Signal	F008.1	F004.1	F052.1
	SFIN	Spindle Speed Function End Signal (1st spindle)	G046.1	G006.1	G054.1
SFRA	Forward Rotation Command Signal (2nd spindle)	G227.5	G227.5		

	Symbol	Signal name	PMC address		
			For M series and T series	For TT series	
				HEAD#1	HEAD#2
S	SFRB	Forward Rotation Command Signal	G235.5	G235.5	
	SHA00 to SHA11	Signals for specifying the stop position in orientation of the serial interface spindle	G230 to G231 G238 to G239	G230 to G231, G238 to G239	
	SKIP1	Skip signal	G000.3	G000.3	G048.3
	SKIP2 to 4	Skip signals	G001.5 to 7		
	SLDMA0 to 15	Serial Interface Spindle Motor Torque Signal	F232 to F233	F232 to F233	
	SLDMB0 to 15	Serial Interface Spindle Motor Torque Signal	F248 to F249	F248 to F249	
	SO	Incremental feed selection signal of software operator's panel	F129.0		
	*SP	Feed Hold Signal	G000.5	G096.5	
	SPA	Spindle override signal	G029.0		
	SPAL	Spindle Speed Fluctuation Alarm Signal	F042.2		
	SPAL1,2,4,8	Spindle Alarm Code Signals	F040.0 to 3	F012.0 to 3	F060.0 to 3
	SPAO	Spindle speed override checking signal	F042.4		
	SPA	Spindle override signal	G029.0		
	SPB	Spindle override signal	G029.1		
	SPBO	Spindle speed override checking signal	F042.5		
	SPB	Spindle override signal	G029.1		
	SPC	Spindle override signal	G029.2		
	SPCO	Spindle speed override checking signal	F042.6		
	SPLDS	Signal for selecting the spindle load display	G047.5		
	SPL	Feed Hold Lamp Signal	F000.3	F096.3	
	SPN0, 1	Spindle control check signals		F013.0, F013.1 F061.0, F061.1	
	SPO	Automatic operation stop signal of software operator's panel	F128.5		
	SPPHS	Spindle phase synchronization signal	G047.7	G111.7	
SPSTP	Spindle Stop Check Signal	G026.0	G026.0		

	Symbol	Signal name	PMC address		
			For M series and T series	For TT series	
				HEAD#1	HEAD#2
S	SPSYAL	Spindle synchronization alarm signal	F046.5	F111.5	
	SPSVC	Spindle synchronization signal	G047.6	G111.6	
	SRN	Program Restart Selection Signal	G002.5		
	SRV	Canned Cycle CCW Rotation Signal	F008.6	F004.6	F052.6
	SRVA	Reverse Rotation Command Signal	G227.4	G227.4	
	SRVB	Reverse Rotation Command Signal	G235.4	G235.4	
	SSP	Canned Cycle Spindle Stop Signal	F008.7	F004.7	F052.7
	SSPAA0 to 7	Serial Interface Spindle Alarm Code Signal (1st spindle)	F236	F236	
	SSPAB0 to 7	Serial Interface Spindle Alarm Code Signal (2nd spindle)	F252	F252	
	SSPDA0 to 15	Serial Interface Spindle Motor Speed Signal (1st spindle)	F234 to F235	F234 to F235	
	SSPDB0 to 15	Serial Interface Spindle Motor Speed Signal (2nd spindle)	F250 to F251	F250 to F251	
	SSTA	Speed Zero Detect Signal (1st spindle)	F229.1	F229.1	
	SSTB	Speed Zero Detect Signal (2nd spindle)	F245.1	F245.1	
	ST	Cycle Start Signal	G005.0	G100.0	
	STFOVR	Feedrate override teaching signal	G031.6		
	STL	Cycle Start Lamp Signal	F000.4	F096.4	
	STP1 to 10	Axis control temporary stop signals (PMC axis control)	G066.5, G070.5 to G102.5	G130.5, G134.5 to G166.5	
	STSOVR	Spindle speed override teaching signal	G031.5		
	SUCLP	Spindle Unclamp Signal	F042.0	F123.0	
	SVALM	Alarm classification signal	F006.1	F101.1	
	*SVF1 to 10	Servo off signals	G064.6, G068.6 to G100.6	G128.6, G132.6 to G164.6	
	SYALM	Alarm classification signal	F006.4	F101.4	
	SYNC1 to 10	Synchronous control selection signals	G066.2, G070.2 to 102.2		
SYNER	Excessive error alarm signal for simple synchronization	F153.1			

	Symbol	Signal name	PMC address		
			For M series and T series	For TT series	
				HEAD#1	HEAD#2
T	T	Tape mode selection signal	G003.4		
	T0 to T31	Tool Function Code Signal	F024 to F027	F024 to F027	F072 to F075
	TAP	Tapping signal	F001.4	F000.4	F048.4
	TCHIN	Teach-in selection signal	G002.3		
	TCHOVR	Override teaching mode signal	G031.7		
	TCLP	Turret clamp signal	F043.1		
	TDIR1	Turret rotation direction selection signal	G030.0		
	TDIR2	Turret rotation direction selection signal	G030.1		
	*TECLP	Turret clamp completion signal	G030.3		
	*TEUCL	Turret unclamp completion signal	G030.2		
	TF	Tool Function Strobe Signal	F008.2	F004.2	F052.2
	TFIN	Tool Function End Signal	G046.2	G006.2	G054.2
	THRD	Threading signal	F001.6	F000.6	F048.6
	TIALM	Alarm classification signal		F101.6	
	TICLK	Signal for checking tool post interference	F120.0		
	TL01 to TL64	Tool group signals	G009.0 to 6	G009.0 to 6	G057.0 to 6
	TL128	Tool group signals	G043.7		
	TL256	Tool group signals	G042.0		
	TLCHA	Tool change signal	F007.6	F003.6	F051.6
	TLCHB	New tool selection signal	F007.7	F003.7	F051.7
	TLMA	Torque in-limited Signal (1st spindle)	F229.6	F229.6	
	TLMB	Torque in-limited Signal (2nd spindle)	F245.6	F245.6	
	TLMHA	Torque Limit Command High Signal (1st spindle)	G227.1	G227.1	
	TLMHB	Torque Limit Command High Signal (2nd spindle)	G235.1	G235.1	
	TLMLA	Torque Limit Command Low Signal (1st spindle)	G227.0	G227.0	
	TLMLB	Torque Limit Command Low Signal (2nd spindle)	G235.0	G235.0	
	TLRST	Tool change reset signal	G010.7	G010.7	G058.7

	Symbol	Signal name	PMC address		
			For M series and T series	For TT series	
				HEAD#1	HEAD#2
T	TLSKP	Tool skip signal	G009.7	G009.7	G057.7
	*TLV0 to 7	Tool life count override signals	G155.0 to 7		
	*TLV8 to 9	Tool life count override signals	G154.0 to 1		
	TMRON	General-purpose integrator start signal	G008.7	G008.7	
	TO	Tape mode selection signal of software operator's panel	F129.4		
	TRACT	Tool retraction mode signal	F044.3	F110.3	
	TRESC	Tool retraction signal	G031.0	G127.0	
	TRHD1	First tool post retraction/recovery mode selection signal		G127.2	
	TRHD2	Second tool post retraction/recovery mode selection signal		G127.3	
	TRMTN	Tool moving signal	F044.4	F110.4	
	TRRTN	Tool recovery signal	G031.1	G127.1	
	TRSPS	Tool recovery completion signal	F044.5	F110.5	
	*TSB	Tail stock barrier selection signal	G030.7		
	TUCLP	Turret unclamp signal	F043.0		
U	UI000 to UI031	Custom macro input signals	G048 to G051	G032 to G035	G080 to G083
	UI100 to UI131	Custom macro input signals	G052 to G055	G036 to G039	G084 to G087
	UI200 to UI231	Custom macro input signals	G056 to G059	G040 to G043	G088 to G091
	UI300 to UI331	Custom macro input signals	G060 to G063	G044 to G047	G092 to G095
	UINT	Interrupt signal for custom macro	G000.2	G000.2	G048.2
	UO000 to UO031	Custom macro output signals	F048 to F051	F032 to F035	F080 to F083
	UO100 to UO131	Custom macro output signals	F052 to F055	F036 to F039	F084 to F087
	UO200 to UO231	Custom macro output signals	F056 to F059	F040 to F043	F088 to F091
	UO300 to UO331	Custom macro output signals	F060 to F063	F044 to F047	F092 to F095
V	VCSKP1 to 10	Velocity command skip signals (PMC axis control)	G067.6 to G103.6	G131.6 to G167.6	

	Symbol	Signal name	PMC address		
			For M series and T series	For TT series	
				HEAD#1	HEAD#2
W	WHEAD	Signal for selecting a tool post for NC window input/output		G111.0	
	WN1,2,4,8,16	External workpiece number search signals	G019.0 to 4	G019.0 to 4	G067.0 to 4
	WOQSM	Signal for selecting the mode for writing the shift distance for the workpiece	G028.6	G028.6	G076.6
	WOSET	Signal for writing the shift distance for the workpiece coordinate system	G026.7	G026.7	G074.7
Z	ZD1 to 10	Reference Point Approach Signal/Arrival Signals			
	ZP1 to 10	Reference Point Return End Signals	F064.0, F068.0 to F100.0	F128.0, F132.0 to F164.0	
	ZP21 to 210	2nd Reference Point Return End Signals	F064.1, F68.1 to F100.1	F128.1, F132.1 to F164.1	
	ZP31 to 310	3rd Reference Point Return End Signals	F064.4, F068.4 to F100.4	F128.4, F132.4 to F164.4	
	ZP41 to 410	4th Reference Point Return End Signals	F064.5, F068.5 to F100.5	F128.5, F132.5 to F164.5	
	ZRN	Manual Reference Point Return Selection Signal	G002.7	G098.7	
	ZRNO	Manual reference position return selection signal of software operator's panel	F128.7		
Nu- me- ric	3DM	Signal indicating that three-dimensional coordinate conversion is in the manual	F157.5		
	without symbol	Key input Signals for specifying a speed in PMC axis control	G128 to G139 See the description of PMC axis control.		

5 TROUBLESHOOTING

This chapter outlines troubleshooting in Section 5.1 and details the action to be taken for each failure in Section 5.2 and subsequent sections.

5.1	CORRECTIVE ACTION FOR FAILURES	271
5.2	POWER CANNOT BE TURNED ON	273
5.3	NO MANUAL OPERATION NOR AUTOMATIC OPERATION CAN BE EXECUTED	276
5.4	JOG OPERATION CANNOT BE DONE	281
5.5	HANDLE OPERATION CANNOT BE DONE	285
5.6	AUTOMATIC OPERATION CANNOT BE DONE	288
5.7	CYCLE START LED SIGNAL HAS TURNED OFF ..	295
5.8	NOTHING IS DISPLAYED ON CRT	297
5.9	SR805 TO SR874 (RELATED TO READER/PUNCH INTERFACE)	298
5.10	REFERENCE POSITION DEVIATES	310
5.11	PS200 (GRID SYNCHRONOUS IS FAILED)	311
5.12	ALARM OT32 (NEED ZRN (ABS PDR))	314
5.13	ALARM SV101 (DATA ERROR (ABS PCDR))	315
5.14	ALARM OT34 (BATTERY ZERO (ABS PCDR))	316
5.15	ALARM SV110 (PULSE CODER ALARM1 (SERIAL))	317
5.16	ALARM SV114 (ABNORMAL REV DATA)	317
5.17	ALARM SV115 (ABNORMAL COMMUNICATION (SERIAL PCDR))	318
5.18	ALARM SV23 (SV OVER LOAD)	319
5.19	ALARM 700 (OVERHEAT AT CONTROL SIDE)	321
5.20	ALARM OT117 (SPINDLE SPEED FLUCTUATION DETECTION ALARM)	322
5.21	ALARM OT300 (SPINDLE SERIAL LINK CANNOT BE STARTED) ..	323

5.1 CORRECTIVE ACTION FOR FAILURES

When a failure occurs, it is important to correctly grasp what kind of failure occurred and take appropriate action, to promptly recover the machine.

Check for the failure according to the following procedure :

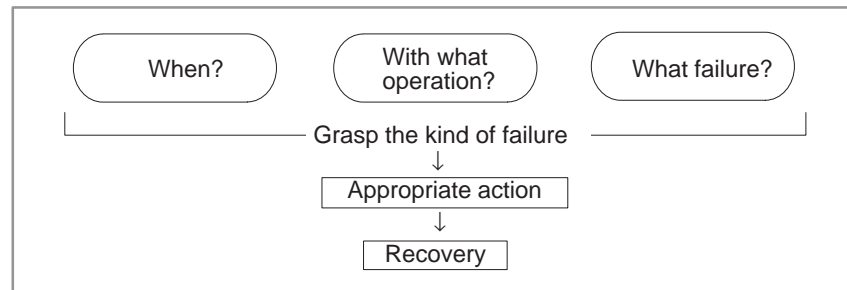

5.1.1 Investigating the Conditions under which Failure Occurred

- (1) When and how many times (frequency of occurrences)
- (2) With what operation
- (3) What failure occurred

1. When did the failure occur?

Date and time?

Occurred during operation? (how long was the operation?)

Occurred when the power was turned on?

Was there any lightening surge, power failure, or other disturbances to the power supply?

How many times has it occurred

Only once?

Occurred many times ? (How many times per hour, per day, or per month?)

2. With what operation did it occur ?

What was the NC mode when the failure occurred?

Jog mode/memory operation mode /MDI mode /reference position return mode

If during program operation,

1) Where in the program ?

2) Which program No. and sequence No. ?

3) What program ?

4) Occurred during axial movement ?

5) Occurred during the execution of an M/S/T code ?

6) Failure specific to the program ?

Does the same operation cause the same failure ?

(Check the repeatability of the failure.)

Occurred during data input/output ?

<Feed axes and spindles>

For a failure related to feed axis servo

1) Occurred at both low feedrate and high feedrate ?

2) Occurred only for a certain axis ?

For a failure related to spindles

When did the failure occur ? (during power-on, acceleration, deceleration, or constant rotation)

3. What failure occurred ?

Which alarm was displayed on the alarm display screen on the CRT?

Are the LEDs on each printed circuit board lit?

If machining dimensions are incorrect

1) How large is the error ?

2) Is the position display on the CRT correct ?

3) Are the offsets correct ?

4. Other information

· Is there noise origin around machine?

If the failure has not occurred frequently, the cause may be external noise to the power supply or inductive noise on machinery cables.

Operate other machines connected to the same power line and see if noise come from the relays or compressors.

· Is it taken any countermeasure for noise in machine side?

· Check the following for the input power supply voltage :

1) Is there variation in the voltage ?

2) Are the voltages different depending on the phase ?

3) Is the standard voltage supplied ?

· How high is the ambient temperature of the control unit?

(0°C to 45°C during operation)

Refer to manual about noise.

· Has excessive vibration been applied to the control unit?

(0.5 G or less during operation)

5. When you contact our service center, specify the following items :

1) Name of the NC unit

2) Name of the machine tool builder and type of machine

3) Software series/version of the NC

4) Specifications of the servo amplifier and motor

(for a failure related to the servo)

5) Specifications of the spindle amplifier and spindle motor

(for a failure related to a spindle)

See the drawing issued by the machine tool builder for the locations of the NC unit and servo/spindle amplifiers.

We use the following specification codes :

Servo /spindle amplifier : A06B-□□□□-H□□□

Servo/spindle amplifier : A06B-□□□□-B□□□

NOTE

□ represents a number

5.2 POWER CANNOT BE TURNED ON

WARNING

Maintenance of a CNC unit involves many dangers and, therefore, must be performed only by a qualified technician.

Points

Confirm the green LED PIL and red LED ALM on the front of power unit.

- 1) Proceed to item 1 when green LED PIL is turned off.
- 2) Proceed to item 2 when green LED is lit and red LED AML is turned off.
- 3) Check item 3 when red LED ALM is lit.

Causes and Remedies

1. LED is turned off

- (1) Fuse F1 or F2 on the power unit front panel is blown.
 - (a) Input power voltage is too high.
 - (b) Power unit is faulty.
- (2) Input voltage is low

Measure voltage at R and S terminals of connector CPI to confirm appropriate voltage is supplied.

If it is not normal, check machine side magnetics circuit.

200VAC, -15%,	50/ 60Hz, ± 1Hz, 1φ
240VAC, +10%,	60Hz, ± 1Hz, 1φ

- (3) Power supply unit is faulty.

2. Conditions for power on are not satisfied. (PIL is lit and ALM is off)

Conditions for power on are as follows:

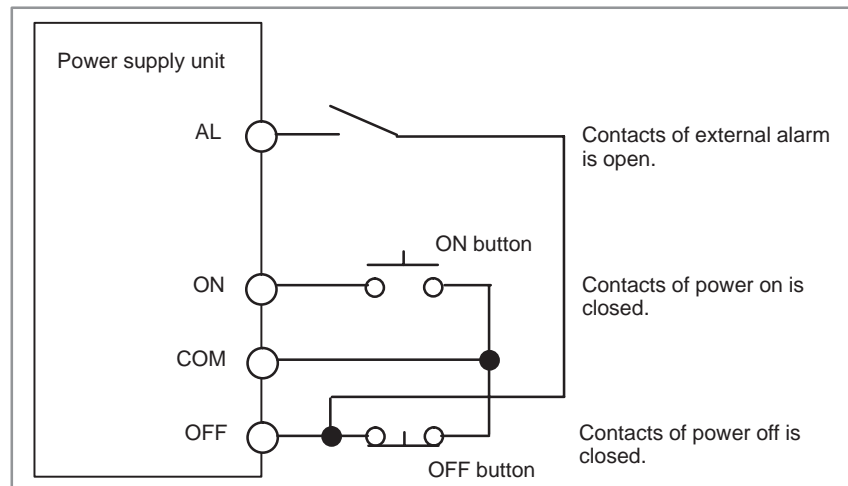

Fig. 5.2 (a)

For details, refer to 2.5.1 Configuration of the Power Supply Unit.

3. LED ALM is lit

- (1) Fuse F3 is blown on the front panel of power unit

Check whether +24V is short-circuited or grounded. (See Fig. 5.2(b)).

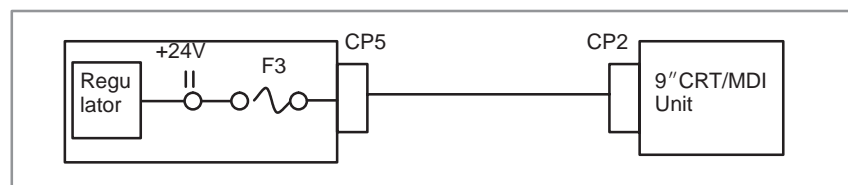

Fig. 5.2 (b)

For details, refer to 2.4.
9" CRT unit is faulty.

- (2) Power supply unit is faulty.
- (a) Remove connector CP2, CP3, CP5, and CP6.
 - (b) Turn off the power of the machine and retract the power unit from the controller.
 - (c) Turn on power of NC.
 - (d) When LED ALM is lit, power unit is faulty.
If ALM is not lit, power supply unit is normal.

WARNING

When a work is conducted with power supply unit removed, perform the work within 30 minutes (Data in memory may be lost)

- (3) Load (+5V) is grounded or short-circuited
- (a) With power supply unit installed on the control unit, turn off the power on the machine side.
 - (b) Remove cables (1) to (3) in the Fig. 5.2 (c), turn on power of NC and check LED ALM.

NOTE

To release lightening of ALM, turn off NC power.

- (c) When LED ALM is turned off while removing the cable, the load connected by the removed wire may be faulty.

CAUTION

When removing the cable note the following :

- 1 If 6V battery is connected as shown Fig. 5.2 (c), absolute position of the machine may be lost when cable (2) is removed. Therefore, the machine position must be established by reference position return ,after releasing the alarm.
- 2 If 6V battery is not connected, the above operation is not needed.

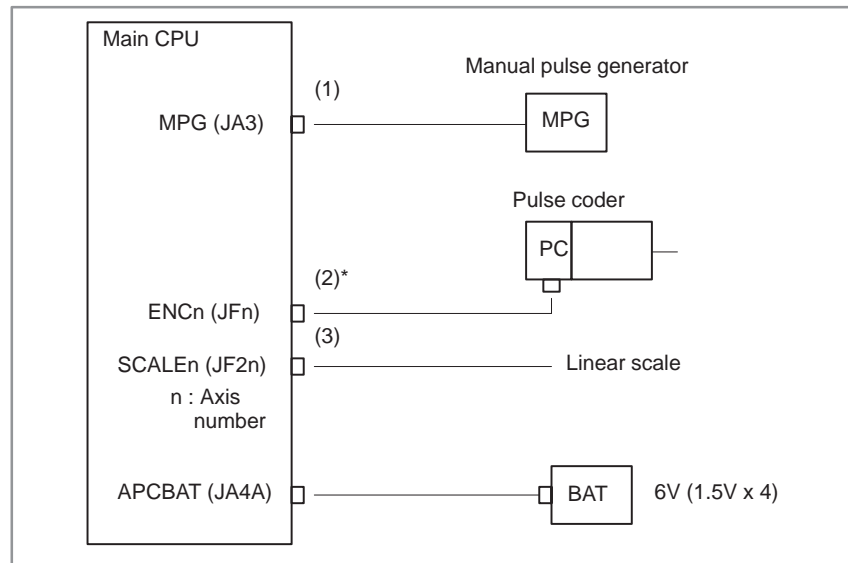

Fig. 5.2 (c)

(d) If ALM does not light by power on of NC, any of load connected to (1) to (3) may be faulty. Check whether grounding or short-circuiting exists or not. If it is present, replace the appropriate part or cable.

(4) Short-circuiting within the controller (PCB may be faulty)

Power is supplied to PCBs through the back panel.

Check it by the steps below :

- 1) Remove a PCB in a slot and turn on power, then confirm lightening of LED ALM. Repeat this operation to each PCB.
- 2) When ALM does not light at power on with a PCB removed, the PCB may be faulty.

WARNING

Perform an operation with a PCB removed within 30 minutes, otherwise data in memory may be lost.

5.3 NO MANUAL OPERATION NOR AUTOMATIC OPERATION CAN BE EXECUTED

Points

- (1) Execute the following procedure when no manual nor automatic operation is done
- (2) Check whether position display shows correct position
- (3) Check CNC status display
- (4) Check CNC internal status using diagnostic function

Causes and Countermeasures

1. Position display (relative, absolute, machine coordinate) does not change

- (1) Check CNC status display (Refer to **2.10 NC STATUS DISPLAY FOR DETAIL**)
 - (a) Emergency stop status (Emergency stop signal is turned on)

If status display shows **EMG** the emergency stop signal is input. Check the following signal using the PMC's diagnostic function (PMCDGN).

	#7	#6	#5	#4	#3	#2	#1	#0
X0006				*ESP				
G0000				*ESP				
G096				*ESP				

(TT series)

ESP=0 indicates that emergency stop signal is input.

(b) It is a reset status

When RESET is displayed, any of a reset is functioned. Check the following signal using the PMC's diagnostic function (PMCDGN).

1 An input signal from the PMC functions

	#7	#6	#5	#4	#3	#2	#1	#0
G0000	ERS	RRW						
G096	ERS	RRW						

(TT series)

When ERS is 1, external reset signal is input.

When RRW is 1, reset & rewinding signal is input.

2 RESET key on the MDI keyboard functions

When the signals in (1) are 0,  key may be functioning.

Check the contact of  key using a tester.

When it is abnormal, change the keyboard.

(c) Confirm the status of modes

Operation mode status is displayed on the lower part of CRT as follows :

If nothing is displayed, mode select signal is not input. Check mode select signal using PMC's diagnostic function (PMCDGN).

For details, refer to section **1.6 NC STATUS DISPLAY**.

(Example of display)

JOG : Manual operation (JOG) mode

HND : Manual handle (MPG) mode

MDI : Manual data input (MDI) mode

MEM : Automatic operation (Memory) mode

EDIT: EDIT (Memory edit) mode

<Mode selection signal>

	#7	#6	#5	#4	#3	#2	#1	#0	
G003		EDT	MEM	T	D	J	H	S	(M/T series)
G097		EDT	MEM		D	J	H	S	(TT series)
	↓	↓	↓	↓	↓	↓	↓	↓	

Incremental (INC) feed	0	0	0	0	0	0	0	1
Manual handle (HND) feed	0	0	0	0	0	0	1	0
Jog (JOG) feed	0	0	0	0	0	1	0	0
Manual data input (MDI)	0	0	0	0	1	0	0	0
Tape command (TAPE)	0	0	0	1	0	0	0	0
Memory command (MEM)	0	0	1	0	0	0	0	0
Tape storage and editing (EDT)	0	1	0	0	0	0	0	0

(2) Check the status according to CNC diagnostic function Nos. 1000 and 1001. Investigate any items for which 1 is displayed on the right.
No. 1000

- a. INPOSITION CHECK
FEEDRATE OVERRIDE 0
- b. JOG FEED OVERRIDE 0
- c. INT./START LOCK ON
SPEED ARRIVAL ON
WAIT REVOLUTION
STOP POSITION CODER
BACKGROUND READING

No. 1001

BACKGROUND READING

- a. In-position check (positioning check) is being performed.

The system indicates that axis movement has not been completed. Check the state of the following diagnostic number. (This item will be 1 under the following condition.)

Diagnostic No. 3000 (position deviation) > Parameter No. 1827 (in-position width)

- (i) Check the value of the parameter using the parameter list.

1825	Servo loop gain for each axis	(Standard value: 3000)
------	-------------------------------	------------------------

- (ii) The servo system may be erroneous. Investigate the servo system according to the description of servo alarms SV023, SV008, and SV009.

- b. The manual feedrate override is 0%.

Check the signals by using the PMC diagnostic function (PMC DGN).

	#7	#6	#5	#4	#3	#2	#1	#0	
G014	*JV15	*JV14	*JV13	*JV12	*JV11	*JV10	*JV9	*JV8	(M/T series)
G015	*JV7	+JV6	*JV5	*JV4	*JV3	*JV2	*JV1	*JV0	(M/T series)
G104	*JV15	*JV14	*JV13	*JV12	*JV11	*JV10	*JV9	*JV8	(TT series)
G105	*JV7	+JV6	*JV5	*JV4	*JV3	*JV2	*JV1	*JV0	(TT series)

When the override is 0%, the bits of the above addresses are set to all 1 or all 0.

- c. An interlock/start lock signal is being input.

Check the signal by using the PMC diagnostic function (PMC DGN).

- (i) The interlock signal (*IT) is being input.

	#7	#6	#5	#4	#3	#2	#1	#0	
G000								*IT	(M/T series)
G096								*IT	(TT series)

0 in the *IT bit indicates that the interlock signal is being input.

- (ii) An axis interlock signal (*ITn), servo off signal (*SVFn), or controlled axis detachment signal (DTCHn) is being input.

	#7	#6	#5	#4	#3	#2	#1	#0	
G064	DTCH1	*SVF1		*IT1					(M/T series first axis)
G128	DTCH1	*SVF1		*IT1					(TT series first axis)

The address for the nth axis is as follows:

M/T series: $64 + (n - 1) * 4$

TT series: $128 + (n - 1) * 4$

0 in the *ITn or *SVFn bit or 1 in the DTCHn bit indicates that the corresponding signal is being input.

(iii) The automatic operation all-axis interlock signal (*AIT) or block start interlock signal (*BSL) is being input.

G001	#7	#6	#5	#4	#3	#2	#1	#0	(M/T series)
							*BSL	*AIT	
G001	#7	#6	#5	#4	#3	#2	#1	#0	(TT series HEAD #1)
							*BSL	*AIT	
G049	#7	#6	#5	#4	#3	#2	#1	#0	(TT series HEAD #2)
							*BSL	*AIT	

0 in the *AIT or *BSL bit indicates that the corresponding signal is being input.

(iv) The cutting block start interlock signal (*CSL) is being input.

G000	#7	#6	#5	#4	#3	#2	#1	#0	(M/T series)
							*CSL		
G000	#7	#6	#5	#4	#3	#2	#1	#0	(TT series HEAD #1)
							*CSL		
G048	#7	#6	#5	#4	#3	#2	#1	#0	(TT series HEAD #2)
							*CSL		

0 in the *CSL bit indicates that the interlock signal is being input.

(3) Check the following parameters to determine whether controlled axis detachment has been specified.

0012	#7	#6	#5	#4	#3	#2	#1	#0
RMVx								

#7 (RMVx) 0 : Does not place the relevant axis in the controlled axis detached state.
 1 : Places the relevant axis in the controlled axis detached state.

1005	#7	#6	#5	#4	#3	#2	#1	#0
RMBx								

#7 (RMBx) The controlled axis detachment signal for the relevant axis (DTCHn) and the setting of bit 7 of parameter No. 0012 (RMVx) are:
 0 : Disabled.
 1 : Enabled.

(4) If the option for index table indexing is being used, check the setting of the index table indexing axis. If the index table indexing sequence on the PMC is incorrect, the index table indexing axis is placed in the servo off state.

7631	Index table indexing controlled axis number
------	---

When this parameter is set to 0, the fourth axis is the index table indexing axis.

2. Position display (machine coordinates) does not change

The machine lock signal (MLK) is being input.

	#7	#6	#5	#4	#3	#2	#1	#0	
G004	MLK								(M/T series)
G099	MLK							*1T	(TT series)
G065					MLK1				(M/T series first axis)
G129					MLK1				(TT series first axis)

The address for the nth axis is as follows:

M/T series: $65 + (n - 1) * 4$

TT series: $129 + (n - 1) * 4$

MLK All-axis machine lock

MLKn Axis machine lock

1 in each bit indicates that the corresponding machine lock signal is being input.

5.4

JOG OPERATION CANNOT BE DONE

Points

- (1) Check whether position display is operating.
- (2) Check CNC status display
- (3) Check internal status using Diagnostic function

Causes and Remedies

1. Position display (relative, absolute, machine coordinate) does not change

- (1) Check mode selection status (JOG mode is not selected)

When status display shows JOG, it is normal.

When status display does not show JOG, mode select signal is not selected correctly. Confirm the mode select signal using PMC's diagnostic function (PMCDGN).

<Mode select signal>

	#7	#6	#5	#4	#3	#2	#1	#0	
G003						J			(M/T series)
G097						J			(TT series)

- (2) Feed axis and direction select signal is not input Check the signal using PMC's diagnostic function (PMCDGN).

	#7	#6	#5	#4	#3	#2	#1	#0
G100	+J8	+J7	+J6	+J5	+J4	+J3	+J2	+J1
G102	-J8	-J7	-J6	-J5	-J4	-J3	-J2	-J1

Example)

When +X button is pressed on the operator's panel, signal+J1 turns to 1.

- * This signal is effected at its rise. If axis selection signal is input before JOG mode is selected, axis movement does not occur. Turn the signal to off, then on.

- (3) Check the status according to CNC diagnostic function Nos. 1000 and 1001. Investigate any items for which 1 is displayed on the right. No. 1001

- a. INPOSITION CHECK
FEEDRATE OVERRIDE 0
- b. JOG FEED OVERRIDE 0
- c. INT./START LOCK ON
SPEED ARRIVAL ON
WAIT REVOLUTION
STOP POSITION CODER
BACKGROUND READING

No. 1001

BACKGROUND READING

- a. In-position check (positioning check) is being performed.

The system indicates that axis movement has not been completed. Check the state of the following diagnostic number. (This item will be 1 under the following condition.)

Diagnostic No. 3000 (position deviation) > Parameter No. 1827 (in-position width)

- (i) Check the value of the parameter using the parameter list.

1825	Servo loop gain for each axis (Standard value: 3000)
------	--

- (ii) The servo system may be erroneous. Investigate the servo system according to the description of servo alarms SV023, SV008, and SV009.

- b. The manual feedrate override is 0%.

Check the signals by using the PMC diagnostic function (PMC DGN).

	#7	#6	#5	#4	#3	#2	#1	#0	
G014	*JV15	*JV14	*JV13	*JV12	*JV11	*JV10	*JV9	*JV8	(M/T series)
G015	*JV7	+JV6	*JV5	*JV4	*JV3	*JV2	*JV1	*JV0	(M/T series)
G014	*JV15	*JV14	*JV13	*JV12	*JV11	*JV10	*JV9	*JV8	(TT series)
G015	*JV7	+JV6	*JV5	*JV4	*JV3	*JV2	*JV1	*JV0	(TT series)

When the override is 0%, the bits of the above addresses are set to all 1 or all 0.

- c. An interlock/start lock signal is being input.

Check the signal by using the PMC diagnostic function (PMC DGN).

- (i) The interlock signal (*IT) is being input.

	#7	#6	#5	#4	#3	#2	#1	#0	
G000								*IT	(M/T series)
G096								*IT	(TT series)

0 in the *IT bit indicates that the interlock signal is being input.

- (ii) An axis interlock signal (*ITn), servo off signal (*SVFn), or controlled axis detachment signal (DTCHn) is being input.

	#7	#6	#5	#4	#3	#2	#1	#0	
G064	DTCH1	*SVF1		*IT1					(M/T series first axis)
G128	DTCH1	*SVF1		*IT1					(TT series first axis)

The address for the nth axis is as follows:

M/T series: $64 + (n - 1) * 4$

TT series: $128 + (n - 1) * 4$

0 in the *ITn or *SVFn bit or 1 in the DTCHn bit indicates that the corresponding signal is being input.

- (iii) The automatic operation all-axis interlock signal (*AIT) or block start interlock signal (*BSL) is being input.

	#7	#6	#5	#4	#3	#2	#1	#0	
G001							*BSL	*AIT	(M/T series)
G001							*BSL	*AIT	(TT series HEAD #1)
G049							*BSL	*AIT	(TT series HEAD #2)

0 in the *AIT or *BSL bit indicates that the corresponding signal is being input.

- (iv) The cutting block start interlock signal (*CSL) is being input.

	#7	#6	#5	#4	#3	#2	#1	#0	
G000							*CSL		(M/T series)
G000							*CSL		(TT series HEAD #1)
G048							*CSL		(TT series HEAD #2)

0 in the *CSL bit indicates that the interlock signal is being input.

- (4) Check the following parameters to determine whether controlled axis detachment has been specified.

	#7	#6	#5	#4	#3	#2	#1	#0
0012	RMVx							

- #7 (RMVx) 0 : Does not place the relevant axis in the controlled axis detached state.
- 1 : Places the relevant axis in the controlled axis detached state.

	#7	#6	#5	#4	#3	#2	#1	#0
1005	RMBx							

- #7 (RMBx) The controlled axis detachment signal for the relevant axis (DTCHn) and the setting of bit 7 of parameter No. 0012 (RMVx) are:
- 0 : Disabled.
- 1 : Enabled.

- (5) If the option for index table indexing is being used, check the setting of the index table indexing axis. If the index table indexing sequence on the PMC is incorrect, the index table indexing axis is placed in the servo off state.

7631

Index table indexing controlled axis number

When this parameter is set to 0, the fourth axis is the index table indexing axis.

- (6) Jog feed rate setting (Parameter) is not correct

1423

Jog feedrate per axis

[mm/min]

5.5 HANDLE OPERATION CANNOT BE DONE

Points

- (1) Check another manual operation (JOG) is accepted.
- (2) Check CNC status display

Causes and Countermeasure

1 JOG operation is not acceptable, either

Consult with sections 5.3 and 5.4.

2 When only handle operation (MPG) cannot be done

- (1) Check CNC status display at lower left corner of the CRT
When the status display shows HND, mode selection is correct.
If it is not HND, mode select signal is not input correctly. Check the mode select signal using the PMC's diagnostic function (PMCDGN).

	#7	#6	#5	#4	#3	#2	#1	#0	
G003							H		(M/T series)
	#7	#6	#5	#4	#3	#2	#1	#0	
G097							H		(TT series)

- (2) Manual handle feed axis select signal is not input

Check the signals using PMC's diagnostic function (PMCDGN).

	#7	#6	#5	#4	#3	#2	#1	#0	
G010					HS3D	HS3C	HS3B	HS3A	(M/T series)
	#7	#6	#5	#4	#3	#2	#1	#0	
G011	HS2D	HS2C	HS2B	HS2A	HS1D	HS1C	HS1B	HS1A	
	#7	#6	#5	#4	#3	#2	#1	#0	
G102					HS3D	HS3C	HS3B	HS3A	
	#7	#6	#5	#4	#3	#2	#1	#0	
G103	HS2D	HS2C	HS2B	HS2A	HS1D	HS1C	HS1B	HS1A	(TT series)

When axis select switch for manual handle feed is selected on the machine operator's panel, if the signals are input as follows, it is normal.

Selected axis	HSnD	HSnC	HSnB	HSnA
no selection	0	0	0	0
1st axis	0	0	0	1
2nd axis	0	0	1	0
3rd axis	0	0	1	1
4th axis	0	1	0	0
5th axis	0	1	0	1
6th axis	0	1	1	0
7th axis	0	1	1	1
8th axis	1	0	0	0

NOTE

In the above table, n is the number of the manual pulse generator (MPG) and up to 3 MPGs can be used. A feed axis is selected by 4-bit code of A to D.

(3) Manual handle feed multiplication is not correct

Check the following signals using PMC's PCDGN. Also confirm the following parameters based on the parameter list.

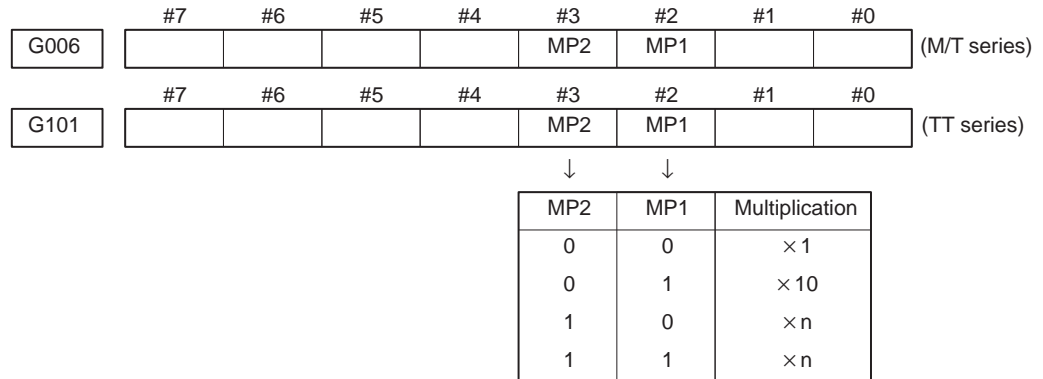

1414	Magnification of handle feed	n (1 to 2000)
------	------------------------------	---------------

(4) Checking manual pulse generator

(a) Incorrect of cable

Check disconnection of cable or short circuit.

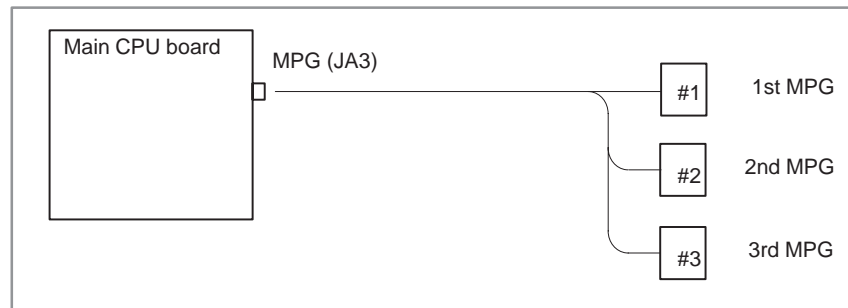

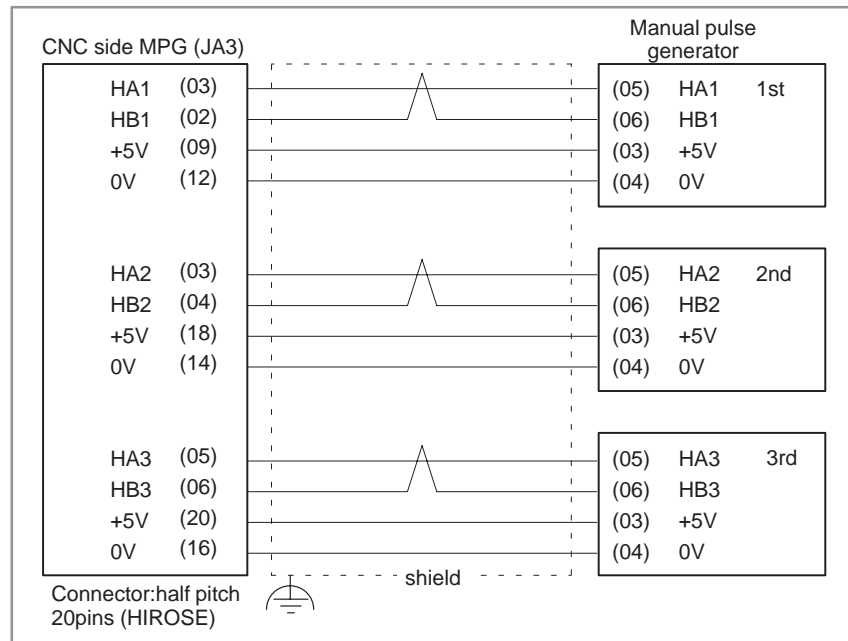

(b) Manual pulse generator is faulty

When you rotate the MPG, the following signal is output.

Measure the signal with synchroscope at screw terminal on back of MPG. If no signal is output, measure +5V voltage.

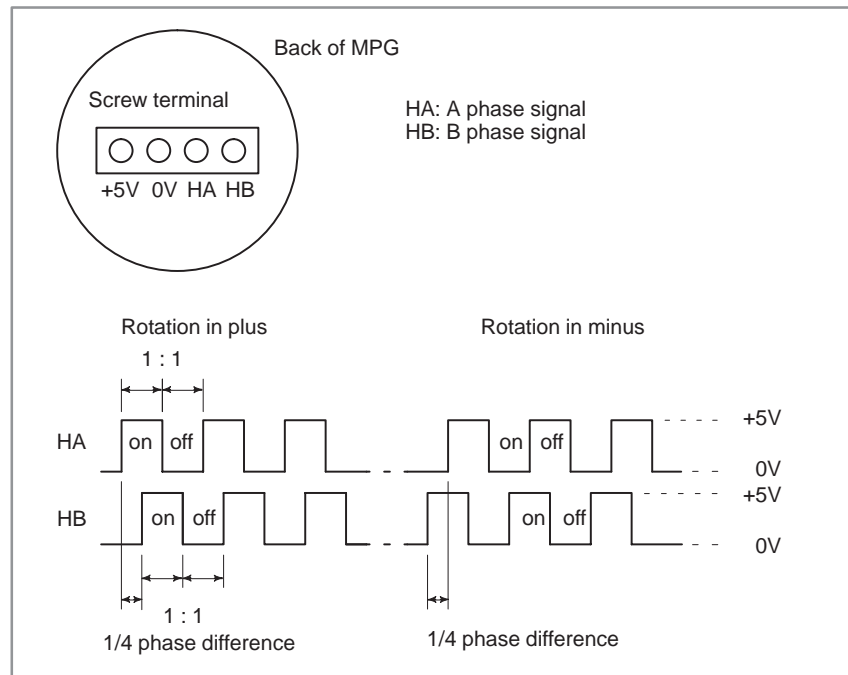

Check on and off ratio and phase difference of HA and HB.

5.6 AUTOMATIC OPERATION CANNOT BE DONE

Points

- (1) Check manual operation is possible.
- (2) Check the status of cycle start LED on machine operator's manual.
- (3) Check status of CNC.

Causes and Remedies

When manual operation is either impossible, perform countermeasure, based on the previous item "Jog operation cannot be done".

Confirm that a correct mode is selected according to the mode select status of CNC status display. Also, by confirming the automatic operation status it is possible to identify cycle operation, feed hold and cycle stop state.

1. When cycle operation is not started (Cycle start LED does not light)

"*****" is displayed at status display on CRT.

- (1) Mode select signal is not correct.

When the mode select signal is input correctly, following status display is done.

MDI : Manual data input mode (MDI)

MEM : Memory operation mode

TAPE : Tape operation mode (not supported by the TT series)

If status display does not show a correct status, check the mode signal with following diagnosis function of PMC side (PMCDGN).

	#7	#6	#5	#4	#3	#2	#1	#0	
G003			MEM	T	D				(M/T series)
G097			MEM		D				(TT series)

MEM Memory operation mode

T Tape operation mode

D Manual data input (MDI) mode

- (2) Cycle start signal is not input

This signal turns 1 when cycle start button is pressed and turns 0 when it is released. The cycle start actuates when it changes from 1 to 0.

Check the state of the signal using PMC's diagnostic function (PMCDGN).

	#7	#6	#5	#4	#3	#2	#1	#0	
G005								ST	(M/T series)
G100								ST	(TT series)

#0 (ST) Cycle start signal

(3) Feed hold signal is input

Under normal state, the feed hold signal is 1 when the feed hold button is not pressed.

Check the state of this signal using the PMC's diagnostic function (PMCDGN)

	#7	#6	#5	#4	#3	#2	#1	#0	
G000			*SP						(M/T series)
	#7	#6	#5	#4	#3	#2	#1	#0	
G096			*SP						(TT series)

***SP** Feed hold signal

2. When cycle operation is being performed (the start lamp is lit)

(1) Check the status according to CNC diagnostic function Nos. 1000 and 1001. Investigate any items for which 1 is displayed on the right.
No. 1000

- a. INPOSITION CHECK
- b. FEEDRATE OVERRIDE 0
- c. JOG FEED OVERRIDE 0
- d. INT./START LOCK ON
SPEED ARRIVAL ON
WAIT REVOLUTION
STOP POSITION CODER
FOREGROUND READING

No. 1001
BACKGROUND READING

a. In-position check is being performed.

The system indicates that axis movement has not been completed. Check the state of the following diagnostic number. (This item will be 1 under the following condition.)

Diagnostic No. 3000 (position deviation) > Parameter No. 1827 (in-position width)

(i) Check the value of the parameter using the parameter list.

1825	Servo loop gain for each axis	(Standard value: 3000)
------	-------------------------------	------------------------

(ii) The servo system may be faulty. Investigate the servo system according to the description of servo alarms SV023, SV008, and SV009.

b. The feedrate override is 0%.

Check the state of the signals by using the PMC diagnostic function (PMC DGN).

<Normal override signal>

	#7	#6	#5	#4	#3	#2	#1	#0	
G012	*FV7	*FV6	*FV5	*FV4	*FV3	*FV2	*FV1	*FV0	(M/T series, TT series HEAD #1)
	#7	#6	#5	#4	#3	#2	#1	#0	
G060	*FV7	*FV6	*FV5	*FV4	*FV3	*FV2	*FV1	*FV0	(TT series HEAD #2)

<Second override>

	#7	#6	#5	#4	#3	#2	#1	#0	
G013	*AFV7	*AFV6	*AFV5	*AFV4	*AFV3	*AFV2	*AFV1	*AFV0	(M/T series, TT series HEAD #1)
G061	*AFV7	*AFV6	*AFV5	*AFV4	*AFV3	*AFV2	*AFV1	*AFV0	(TT series HEAD #2)

c. The manual feedrate override is 0% (only for dry run).

When the dry run signal is turned on during cycle operation, the following override is enabled for the dry run feedrate. Check the state of the signals by using the PMC diagnostic function (PMC DGN).

	#7	#6	#5	#4	#3	#2	#1	#0	
G014	*JV15	*JV14	*JV13	*JV12	*JV11	*JV10	*JV9	*JV8	(M/T series)
G015	*JV7	+JV6	*JV5	*JV4	*JV3	*JV2	*JV1	*JV0	(M/T series)
G104	*JV15	*JV14	*JV13	*JV12	*JV11	*JV10	*JV9	*JV8	(TT series)
G105	*JV7	+JV6	*JV5	*JV4	*JV3	*JV2	*JV1	*JV0	(TT series)

When the override is 0%, the bits of the above addresses are set to all 1 or all 0.

d. An interlock/start lock signal is being input.

Check the signal by using the PMC diagnostic function (PMC DGN).

(i) The interlock signal (*IT) is being input.

	#7	#6	#5	#4	#3	#2	#1	#0	
G000								*IT	(M/T series)
G096								*IT	(TT series)

0 in the *IT bit indicates that the interlock signal is being input.

(ii) An axis interlock signal (*ITn), servo off signal (*SVFn), or controlled axis detachment signal (DTCHn) is being input.

	#7	#6	#5	#4	#3	#2	#1	#0	
G064	DTCH1	*SVF1		*IT1					(M/T series first axis)
G128	DTCH1	*SVF1		*IT1					(TT series first axis)

The address for the nth axis is as follows:

M/T series: $64 + (n - 1) * 4$

TT series: $128 + (n - 1) * 4$

0 in the *ITn or *SVFn bit or 1 in the DTCHn bit indicates that the corresponding signal is being input.

(iii) The automatic operation all-axis interlock signal (*AIT) or block start interlock signal (*BSL) is being input.

	#7	#6	#5	#4	#3	#2	#1	#0	
G001							*BSL	*AIT	(M/T series)
	#7	#6	#5	#4	#3	#2	#1	#0	
G001							*BSL	*AIT	(TT series HEAD #1)
	#7	#6	#5	#4	#3	#2	#1	#0	
G049							*BSL	*AIT	(TT series HEAD #2)

0 in the *AIT or *BSL bit indicates that the corresponding signal is being input.

(iv) The cutting block start interlock signal (*CSL) is being input.

	#7	#6	#5	#4	#3	#2	#1	#0	
G000							*CSL		(M/T series)
	#7	#6	#5	#4	#3	#2	#1	#0	
G000							*CSL		(TT series HEAD #1)
	#7	#6	#5	#4	#3	#2	#1	#0	
G048							*CSL		(TT series HEAD #2)

0 in the *CSL bit indicates that the interlock signal is being input.

(2) Check the following parameters to determine whether controlled axis detachment has been specified.

	#7	#6	#5	#4	#3	#2	#1	#0
0012	RMVx							

#7 (RMVx) 0 : Does not place the relevant axis in the controlled axis detached state.
 1 : Places the relevant axis in the controlled axis detached state.

	#7	#6	#5	#4	#3	#2	#1	#0
1005	RMBx							

#7 (RMBx) The controlled axis detachment signal for the relevant axis (DTCHn) and the setting of bit 7 of parameter No. 0012 (RMVx) are:
 0 : Disabled.
 1 : Enabled.

(3) If the option for index table indexing is being used, check the setting of the index table indexing axis. If the index table indexing sequence on the PMC is incorrect, the index table indexing axis is placed in the servo off state.

7631	Index table indexing controlled axis number
------	---

When this parameter is set to 0, the fourth axis is the index table indexing axis.

(4) If only rapid traverse for positioning (G00) fails to function, check the following parameter and signal sent from the PMC:

a. Rapid traverse rate setting

1420	Rapid traverse rate for each axis (mm/min)
------	--

b. Rapid traverse override signal

	#7	#6	#5	#4	#3	#2	#1	#0	
G006		ROV2	ROV1						(M/T series)

	#7	#6	#5	#4	#3	#2	#1	#0	
G101		ROV2	ROV1						(TT series)

Rapid traverse override		Override value
ROV2	ROV1	
0	0	100%
0	1	50%
1	0	Fm% *1
1	1	F% *2

(0: Low, 1: High)

*1 Fm is a percentage between 0 and 100%, specified with parameter No. 1412 (common to all axes).

*2 Fo is the absolute value of the feedrate between 0 and the rapid traverse rate, specified with parameter No. 1421 (for each axis).

	#7	#6	#5	#4	#3	#2	#1	#0	
G040	1	*RV6B	*RV5B	*RV4B	*RV3B	*RV2B	*RV1B	*RV0B	(M/T series)

	#7	#6	#5	#4	#3	#2	#1	#0	
G120	1	*RV6B	*RV5B	*RV4B	*RV3B	*RV2B	*RV1B	*RV0B	(TT series)

$$\text{Override value} = \sum_{i=0}^6 \{2^i \times V_i\} \cdot \%$$

V_i = 0 when *RV_iB is high

V_i = 1 when *RV_iB is low

The above expression means that each signal has the following weight:

- *RV0B : 1%
- *RV1B : 2%
- *RV2B : 4%
- *RV3B : 8%
- *RV4B : 16%
- *RV5B : 32%
- *RV6B : 64%

When all the signals are low, the override value is assumed to be 0%, in the same way as when all the signals are high. If the specified override value exceeds 100%, 100% is assumed.

The following parameter is used to specify which of the above methods of specifying rapid traverse override is applied.

	#7	#6	#5	#4	#3	#2	#1	#0
1402								ROV8

[Parameter input]**[Data type]** Bit type**ROV8** Rapid traverse override is specified as:

0 : Fo, Fm, 50%, or 100%, using two input signals, ROV1 and ROV2.

1 : 0 to 100% (in steps of 1%), using seven input signals, *RV0B to *RV6B.

(5) Only feed (other than G00) does not function

(a) Maximum feed rate set by parameter is incorrect.

1422	Maximum feedrate	[mm/min]
------	------------------	----------

Feed rate is clamped at this upper feed rate.

(b) Feed rate is specified by feed per revolution (mm/rev)

(i) Position coder does not rotate

Check the connection between spindle and position coder

The following failure is considered:

- Timing belt is broken
- Key is removed
- Coupling is loose
- Connector of signal cable is loosened

(ii) Position coder is faulty

(c) Thread cutting does not operate

(i) Position coder does not rotate

Check the connection between spindle and position coder

The following failure is considered:

- Timing belt is broken
- Key is removed
- Coupling is loose
- Connector of signal cable is loosened

(ii) Position coder is faulty

Position coder is connected to the spindle amplifier when serial interface spindle is used or connected to the CNC when analog interface spindle is used.

For details of connection, refer to the following.

<T series>

Whether A/B phase signals from the position coder are read correctly, can be judged also by the spindle speed display on the CRT screen (position screen). (However, it is not displayed when PARAM 3105#2=0).

<Serial spindle amplifier>

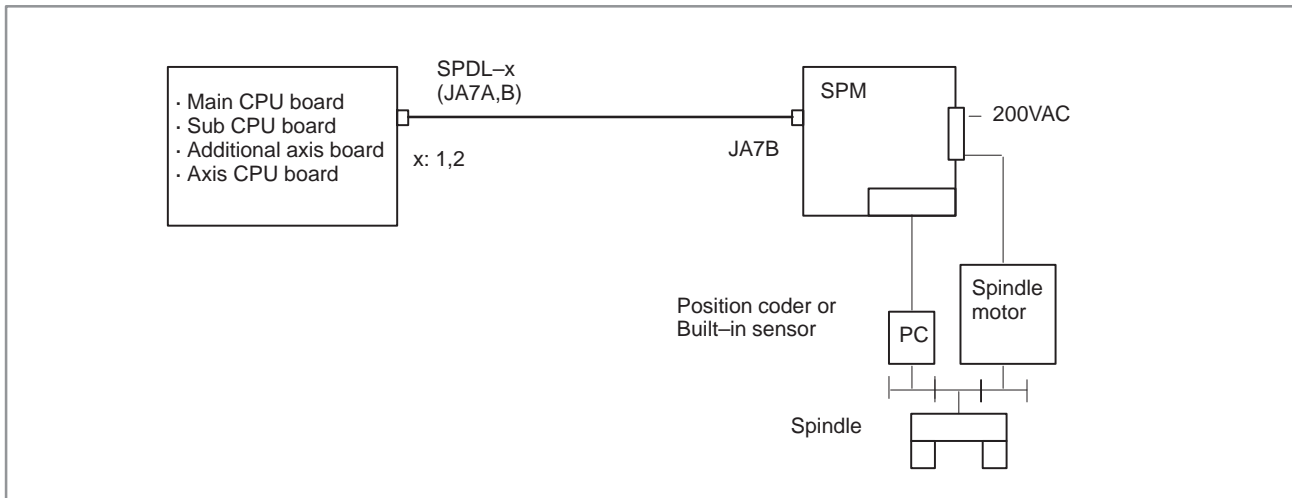

<Analog interface spindle amplifier>

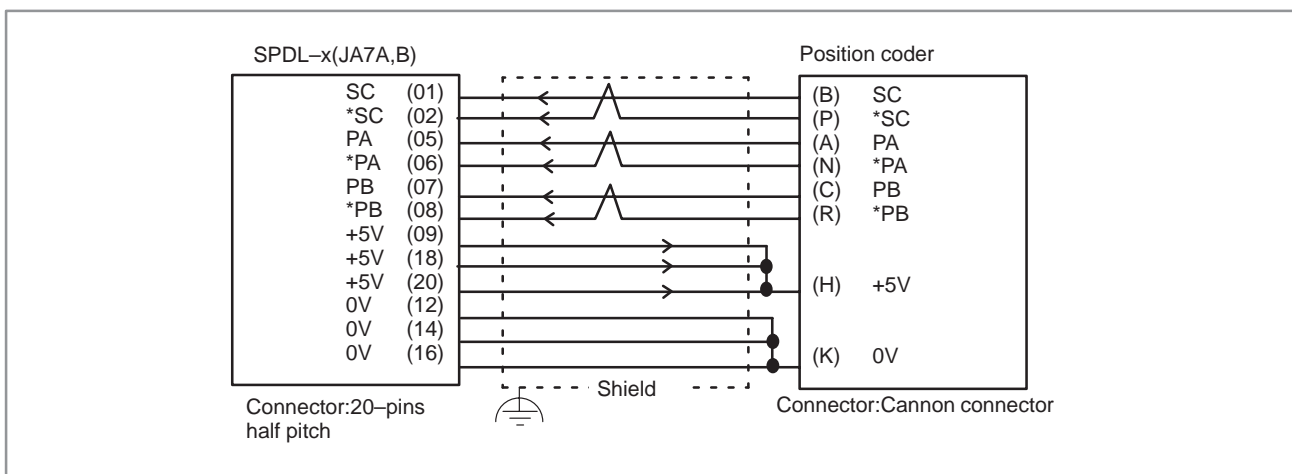
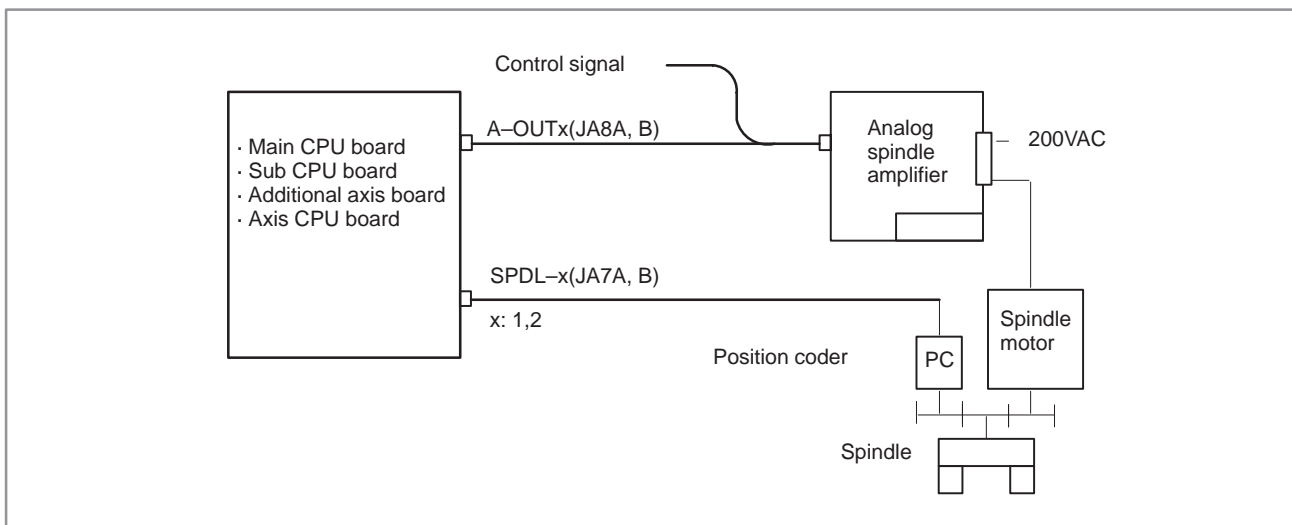

5.7 CYCLE START LED SIGNAL HAS TURNED OFF

Points

- (1) After cycle operation is started, then stopped, check as follows:
- (2) Confirm cycle start LED on machine operator's panel.
- (3) Confirm CNC's diagnostic function

Causes and Remedies

- (1) If the cycle start LED signal (STL) has been turned off due to a reset, check CNC diagnostic No. 1010.

	#7	#6	#5	#4	#3	#2	#1	#0
1010					RST	ERS	RRW	ESP

Each bit indicates the following state when set to 1.

- a. ESP Emergency stop state
- b. RRW The reset & rewind signal is turned on.
- c. ERS The external reset signal is turned on.
- d. RST The reset key has been pressed.

* Details of signals a to d are as follows:
Confirm the signals concerned using diagnostic function (PMCDGN).

a. Emergency stop is input When I/O card is not used:

	#7	#6	#5	#4	#3	#2	#1	#0
X0006				*ESP				
	#7	#6	#5	#4	#3	#2	#1	#0
G0000				*ESP				
	#7	#6	#5	#4	#3	#2	#1	#0
G096				*ESP				

(M/T series)
(TT series)

*ESP=0 : Emergency stop signal is input :

b. Reset & rewind signal is input

	#7	#6	#5	#4	#3	#2	#1	#0
G000		RRW						
	#7	#6	#5	#4	#3	#2	#1	#0
G096		RRW						

(M/T series)
(TT series)

#6 (RRW) When this signal is 1, the reset & rewind signal is input.

* This signal is usually used for a confirmation signal of M30 when an M30 is specified in a program as the end of a program. Therefore, when M30 is executed, this signal is input.

c. External reset signal is input

	#7	#6	#5	#4	#3	#2	#1	#0	
G0000	ERS								(M/T series)
G096	ERS								(TT series)

#7 (ERS) When the bit is 1, external reset signal is input.

- * This signal is usually used for a confirmation signal of M02 when an M02 is specified in a program as the end of a program. Therefore, when M02 is executed, this signal is input.

d. Reset button on the MDI is pressed

An automatic operation is put into a reset status when RESET key on the MDI panel is pressed.

(2) When any servo alarm has generated, cycle operation is put into the reset state and operation stop.

See the message screen to identify the alarm which has been issued.

(3) Cycle operation may be in the feed hold state.

The cycle operation becomes feed hold state in the following cases:

(a) Modes are switched from an automatic operation mode to a manual operation mode.

Automatic operation	Tape operation (TAPE)
	Automatic operation (MEM)
	Manual data input (MDI)
Manual operation	Jog feed (JOG)
	Handle/step

(b) Feed hold signal is input.

<Feed hold signal>

	#7	#6	#5	#4	#3	#2	#1	#0	
G0000			*SP						(M/T series)
G096			*SP						(TT series)

#5 (*SP) When this signal is 0, the feed hold signal is input.

(4) Single-block stop may occur during cycle operation.

Check the following signal:

	#7	#6	#5	#4	#3	#2	#1	#0	
G004					SBK				
G096					SBK				(TT series)

#3 (SBK) When this signal is 1, the single block signal is input.

5.8 NOTHING IS DISPLAYED ON CRT

Points

Check whether it is a trouble of display or a trouble of the system.

Judgement of the point

Check whether the STATUS LED on the main board shows the following state.

	1	2	3	4	
STATUS	○	×	×	×	(○ : on, × : off)

If the status shows the above state, the system is normal.

Therefore, display system may be faulty.

If the status shows other state, a hardware other than the display system may be troublesome.

Causes and remedies

1. When the display system is in trouble

(1) Confirmation item

- 1 Is power supplied to the display?
- 2 Is a video signal connected? Isn't it disconnected? or braked?

(2) Causes and remedies

- 1 Power to the display is faulty. (Exchange power supply unit).
- 2 Cable connection is faulty. (Correct the connection).
- 3 Module is faulty (Exchange CRT control module)
- 4 Display is faulty.

* The CRT control module is mounted on the main CPU board or option 1 board. The location of the module is described in:

Sections 2.5.2 to 2.5.5 : Main CPU board

Section 2.5.19 : Option 1 board

2. When system is in trouble

	1	2	3	4	
STATUS	○	×	×	×	(○ : on, × : off)

When STATUS LED on the main board is other than above, check LEDs on the main CPU board and other optional boards, identify the trouble and make an appropriate action.

5.9 SR805 TO SR874 (RELATED TO READER/PUNCH INTERFACE)

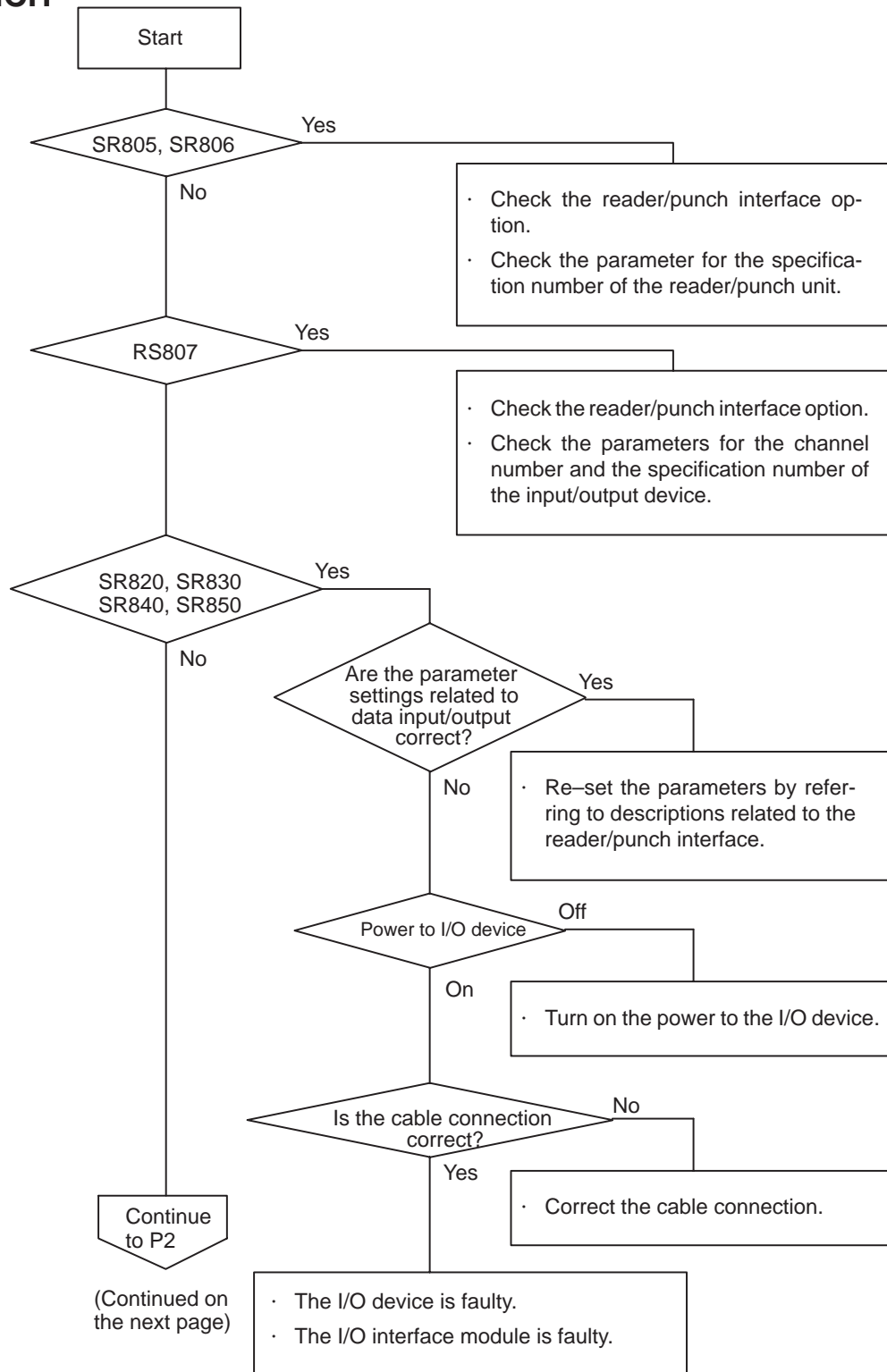

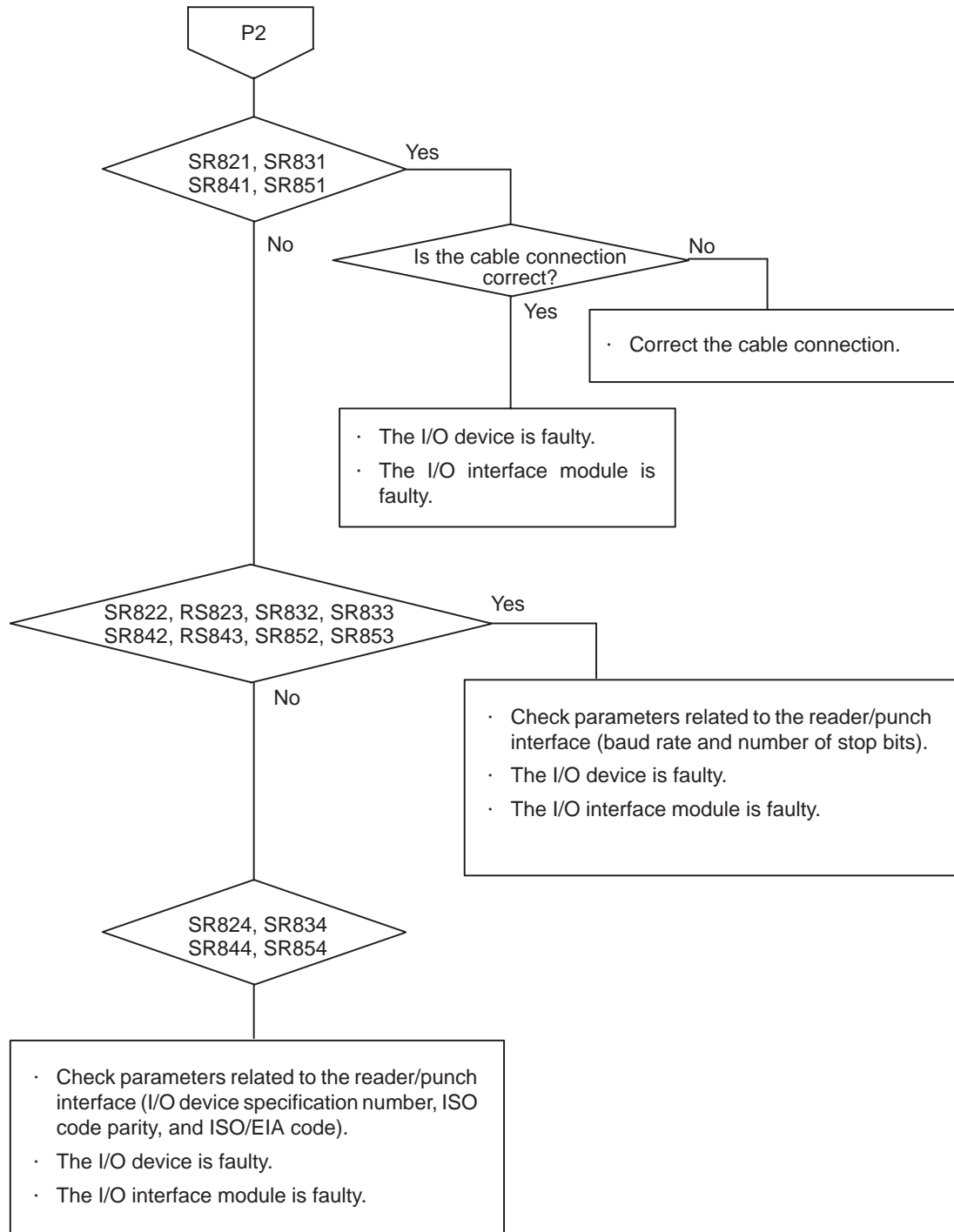
**Cause**

- (a) A parameter setting related to the reader/punch interface is invalid.
- (b) The external input/output device or host computer is faulty.
- (c) The I/O interface module is faulty.
- (d) The cable between the NC and input/output device is faulty.

Action a

A parameter setting related to the reader/punch interface is invalid.

- **Parameters related to reader/punch interfaces**

Correlation diagrams for parameters related to reader/punch interfaces are given below.

Parameters related to the reader/punch interface

The correlation diagrams of the parameters related to the reader/punch interface are given below.

1) Main CPU board + Option 1 board (with communication functions)

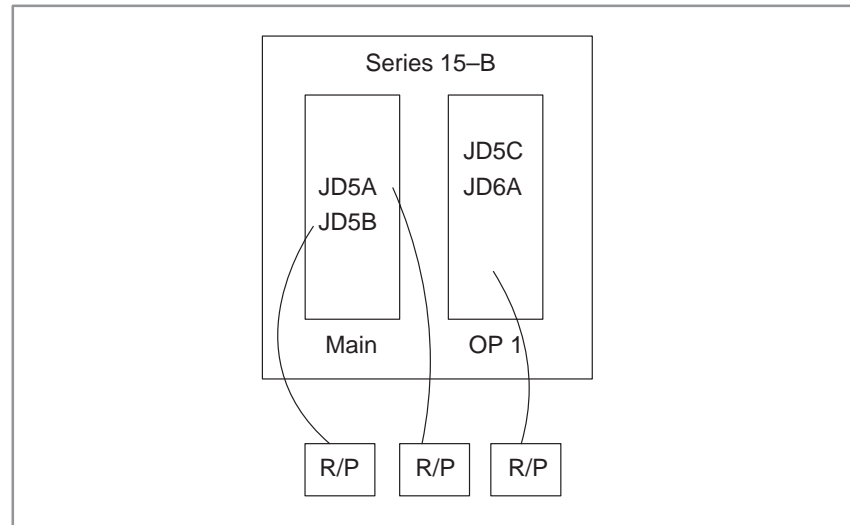

Channel 1 : JD5A of the main CPU board

Channel 2 : JD5B of the main CPU board

Channel 10 : JD5C (RS-232-C) or JD6A (RS-422) of OP1.

Only one of the two can be used.

Which is used is specified with bit 0 of parameter No. 5000.

2) Main CPU board + Additional axis board (SUB, ADAX)

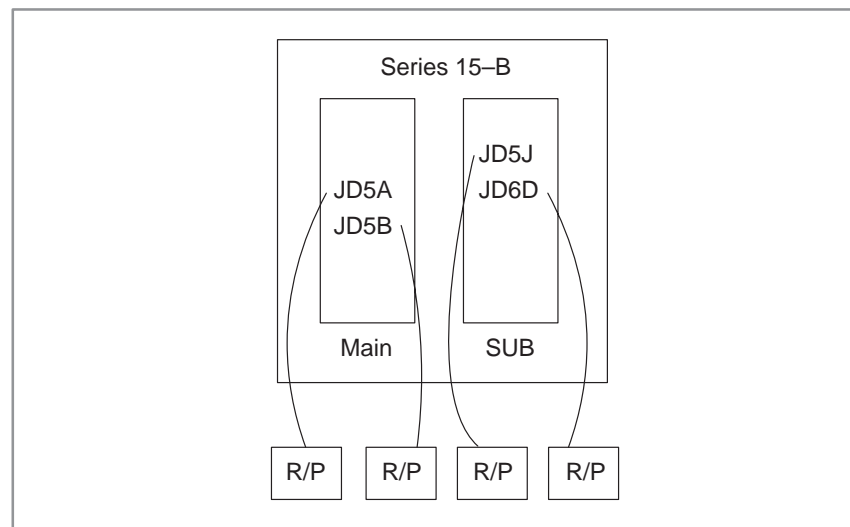

Channel 1 : JD5A of the main CPU board

Channel 2 : JD5B of the main CPU board

Channel 3 : JD5J of the sub-board

Channel 13 : JD6D of the sub-board

3) Main CPU board + Sub-board (additional axis) + Option 1 board
(with communication functions)

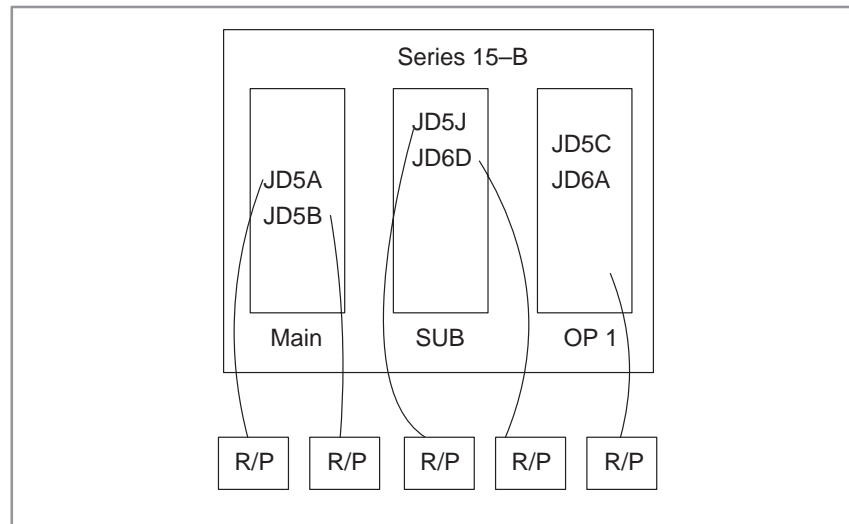

Channel 1 : JD5A of the main CPU board

Channel 2 : JD5B of the main CPU board

Channel 3 : JD5J of the sub-board

Channel 13 : JD6D of the sub-board

Channel 10 : JD5C or JD6A of OP1.

Only one of the two can be used.

Which is used is specified with bit 0
of parameter No. 5000.

Connector for RS-232-C : JD5A, JD5B, JD5C, JD5J

Connector for RS-422 : JD6A, JD6D

NOTE

The option 1 board contains a remote buffer.

Each reader/punch unit is temporarily assigned device numbers 1 to 6.

When you have four reader/punch units, for example, assign device numbers 1 to 4 to them.

Set the specifications of the assigned reader/punch units in parameter Nos. 5110 to 5162. Set the device numbers of the reader/punch units connected to channels 1, 2, 3, and 13 in parameter Nos. 5001, 5002, 5003, and 5013.

Set the specifications of the host computer connected to the remote buffer in parameter Nos. 5071 to 5084. A parameter that specifies which reader/punch unit is connected to channel 10 is not provided because the remote buffer is always connected to channel 10.

Parameter Nos. 0020 to 0023 select which channels are used as input/output units for foreground/background. These parameters are normally set on a dedicated screen called the SETTING HANDY screen.

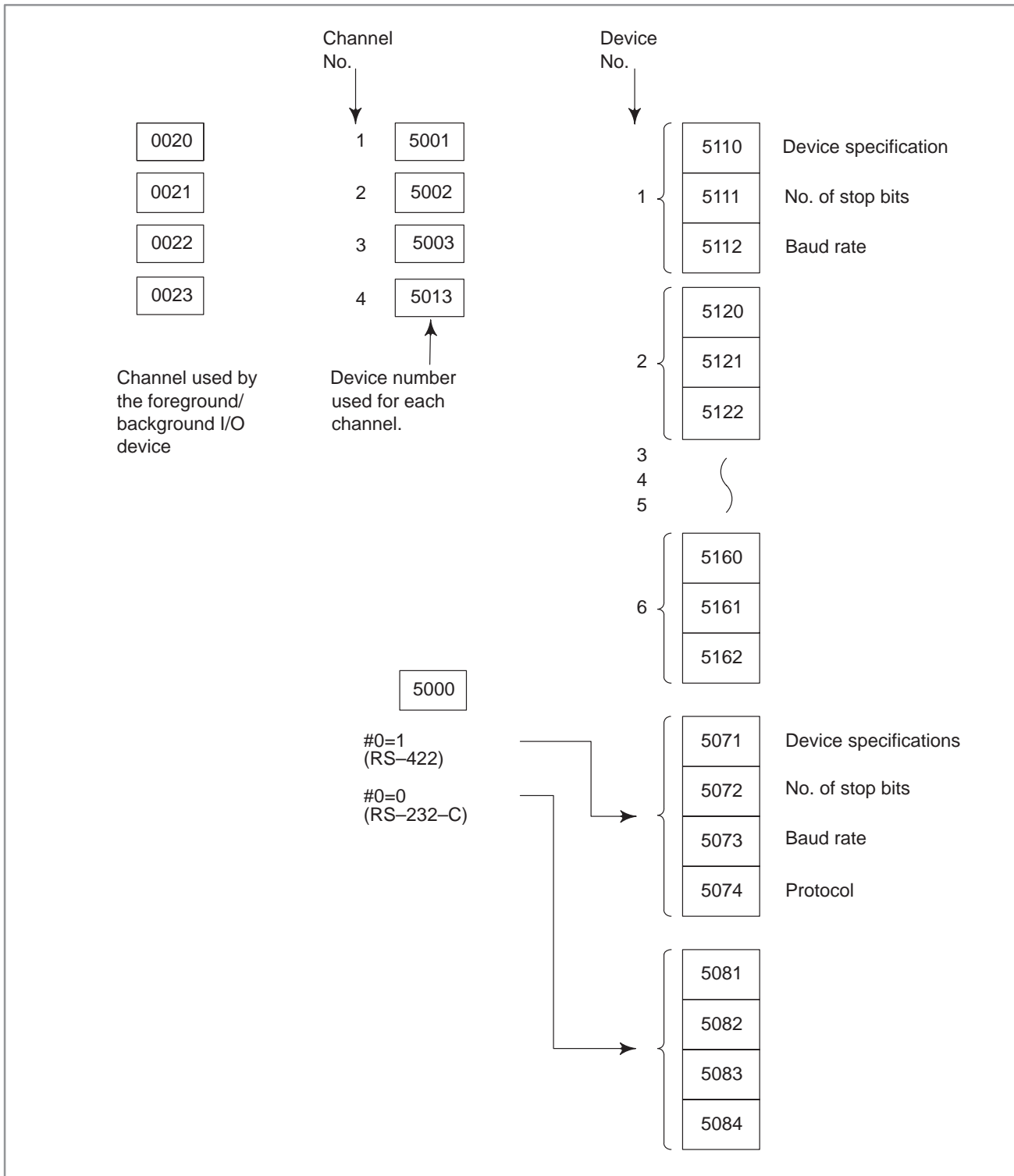

● Settings

	#7	#6	#5	#4	#3	#2	#1	#0
0000			DNC	EIA	NCR	ISP	CTV	TVC

[Setting input]

[Data type] Bit

TVC Specifies whether TV check is performed.

- 0 : Do not perform.
- 1 : Perform.

CTV Specifies whether characters are counted for TV check during control out.

- 0 : Count.
- 1 : Do not count.

ISP Specifies whether ISO codes contain a parity bit.

- 0 : Contain parity bit.
- 1 : Do not contain parity bit.

(A parity bit is located at channel 8 in a punched tape in the ISO code.)

NCR Specifies how to punch an EOB (end-of-block) code when using ISO codes.

- 0 : Punch LF CR CR.
- 1 : Punch LF.

EIA Specifies the code system to use for punch codes.

- 0 : ISO code
- 1 : EIA code

● Parameter

0020	Interface No. of input device for foreground
------	--

[Setting input]

[Data type] Bit

Assignment of input device numbers for foreground

- 0 : Reader connected to JD5A of main CPU board
- 1 : Reader connected to JD5A of main CPU board
(Settings 0 and 1 are identical.)
- 2 : Reader connected to JD5B of main CPU board
- 3 : Reader connected to JD5J of the subboard
- 13: Reader connected to JD6D of the subboard

Perform system reset after setting this parameter.

0021	Interface No. of output device for foreground
------	---

[Setting input]

[Data type] Bit

Assignment of output device numbers for foreground

- 1 : Punch connected to JD5A of main CPU board
- 2 : Punch connected to JD5B of main CPU board
- 3 : Punch connected to JD5J of the subboard
- 13: Punch connected to JD6D of the subboard

Perform system reset after setting this parameter.

0022	Interface No. of input device for background
------	--

[Setting input]**[Data type]** Byte

Assignment of input device numbers for background

0 : Reader connected to JD5A of main CPU board

1 : Reader connected to JD5A of main CPU board
(Settings 0 and 1 are identical.)

2 : Reader connected to JD5B of main CPU board

3 : Reader connected to JD5J of the subboard

13: Reader connected to JD6D of the subboard

Perform system reset after setting this parameter.

0023	Interface No. of output device for background
------	---

[Setting input]**[Data type]** Byte

Assignment of output device numbers for background

1 : Punch connected to JD5A of main CPU board

2 : Punch connected to JD5B of main CPU board

3 : Punch connected to JD5J of the subboard

13: Punch connected to JD6D of the subboard

Perform system reset after setting this parameter.

5001	Device number of reader/punch unit connected to JD5A of MAIN
------	--

5002	Device number of reader/punch unit connected to JD5B of MAIN
------	--

5003	Device number of reader/punch unit connected to JD5J of additional axis board
------	---

[Setting input]**[Data type]** Byte**[Valid data range]** 1 to 6

Set the device numbers of the reader/punch units connected to connectors CD4A, CD4B, and CD4.

Set the code numbers of the reader/punch units corresponding to device numbers 1 to 6 in parameter Nos. 5100 to 5162.

5013	Device number of reader/punch unit connected to JD6D of additional axis board
------	---

[Setting input]**[Data type]** Byte**[Valid data range]** 1 to 6

Set the device numbers of the reader/punch units connected to the RS-422 interface.

Set the code numbers of the reader/punch units corresponding to device numbers 1 to 6 in parameter Nos. 5100 to 5162.

5060

HDLC baud rate in DNC1

[Setting input]**[Data type]** Byte

Set this parameter to 51 because the HDLC baud rate is fixed at 460K bps in DNC1.

Action b

- **The external input/output device or host computer is faulty**

- (1) Check that the communication settings made for the external input/output device or host computer are the same as those made for the NC (such as the baud rate and number of stop bits). If they are found to be different, correct the settings.
- (2) If an alternative input/output device is available, check whether communication is normal when that device is used.

Action c

- **The I/O interface module or communication control module is faulty**

- The module mounted on one of the following optional printed circuit boards, depending on the setting of parameter No. 0020, may be defective. Replace the module.

Setting of parameter No. 0020	Module is mounted on:	Remarks
0, 1, 2	Main CPU printed circuit board	See Sections 2.5.2 to 2.5.5.
3, 13	Sub-CPU printed circuit board	See Sections 2.5.15 to 2.5.17.
4, 10	Option 1 printed circuit board	See Section 2.5.19.

Action d

- **Cable between NC and I/O device is faulty**

Check the cable for disconnection or wrong connection.

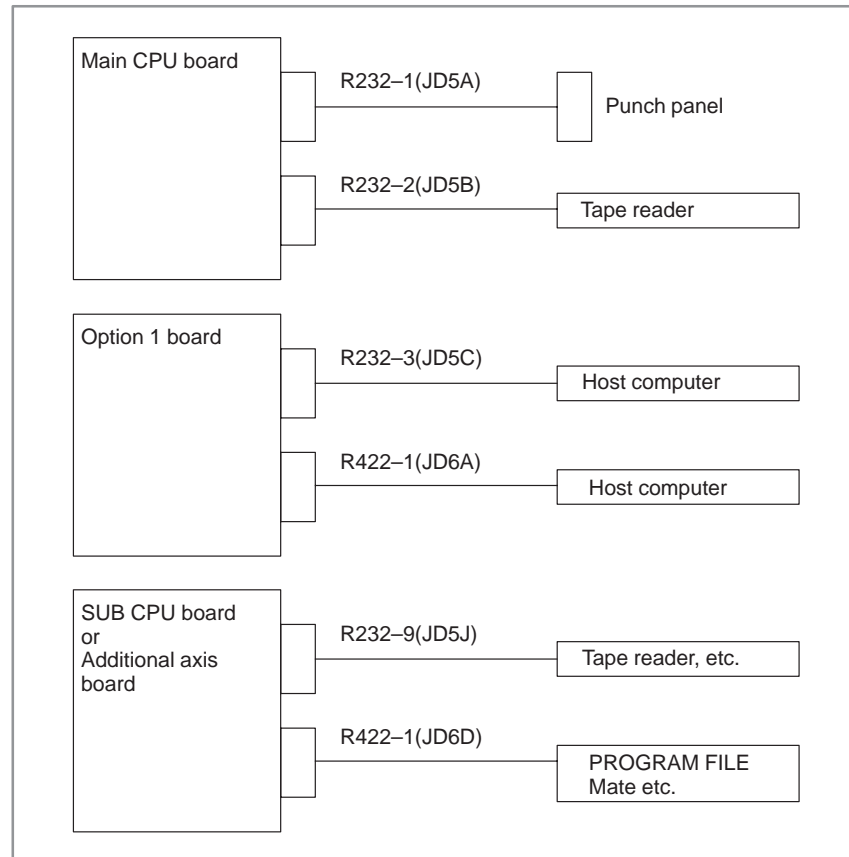

< Cable connection >

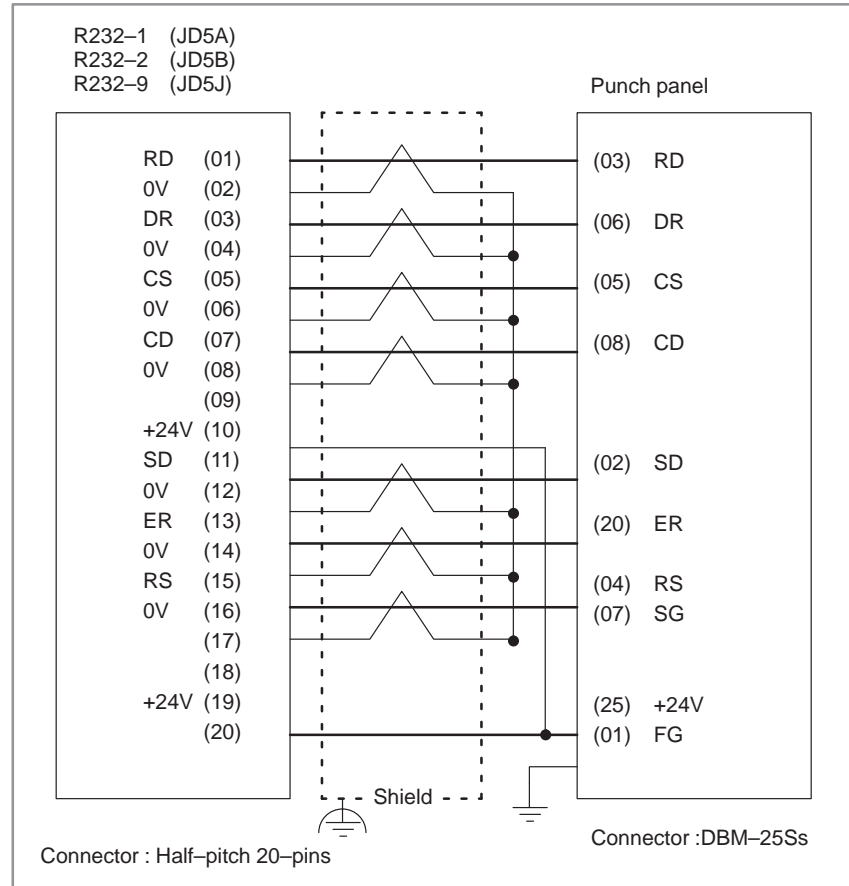

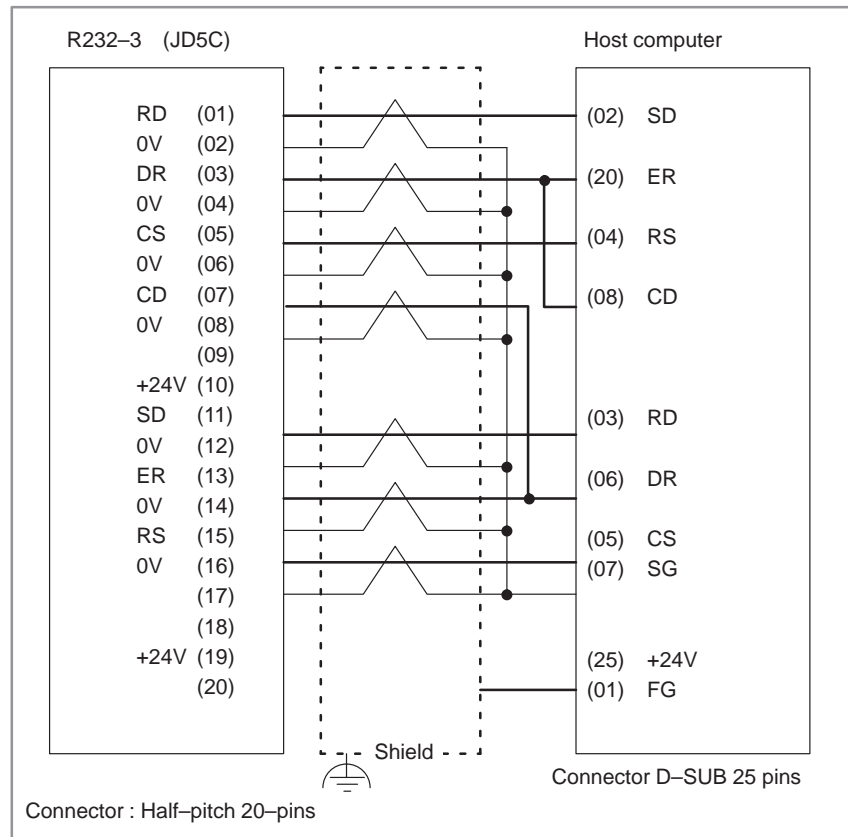

NOTE

- 1 When CS is not used, connect it to RS.
- 2 For protocol A or extended protocol A: When DR is not used, connect it to ER. Always connect CD to ER.

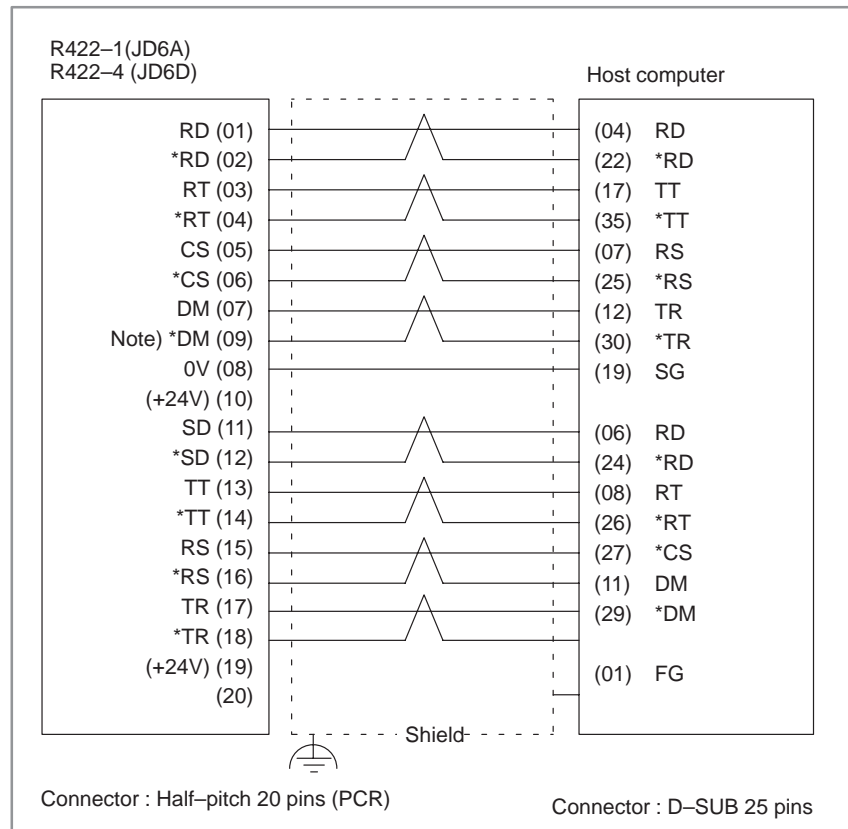

NOTE

Always use a twisted pair cable.

5.10 REFERENCE POSITION DEVIATES

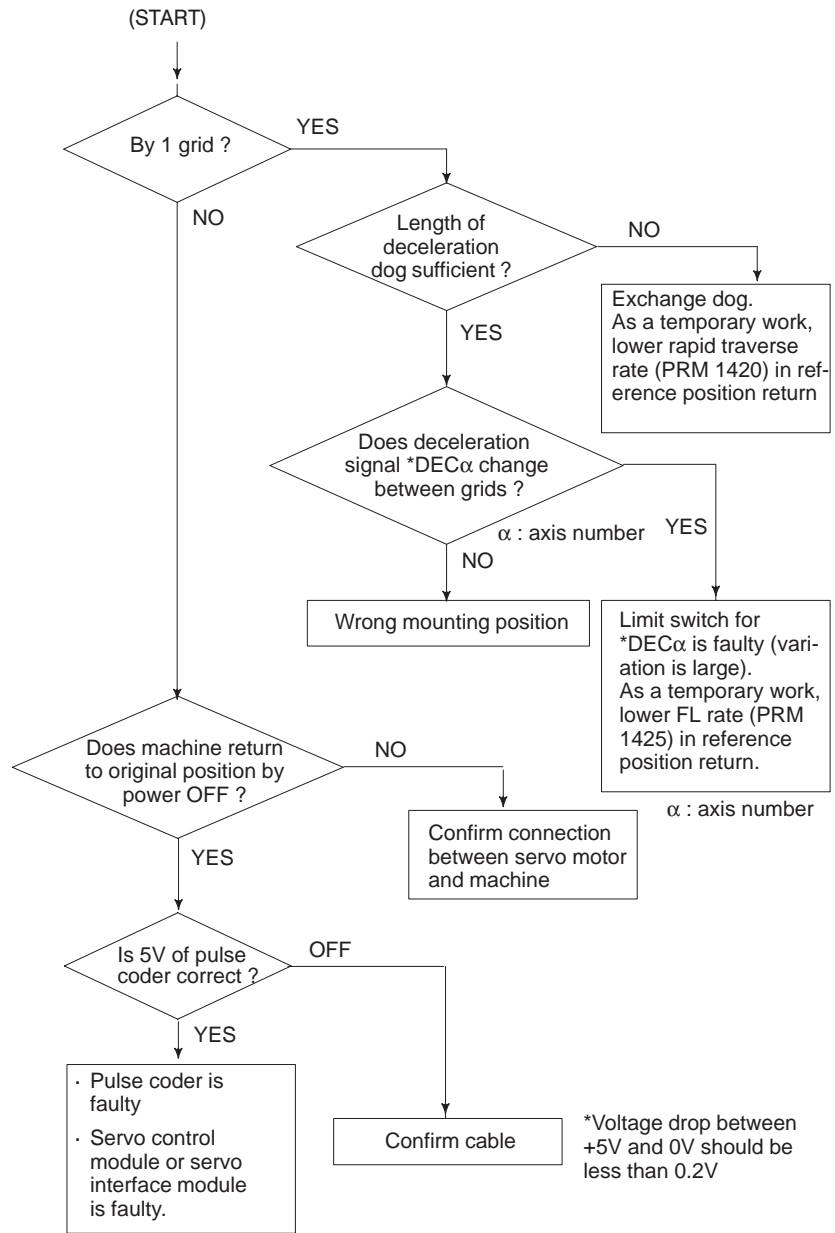

5.11 PS200 (GRID SYNCHRONOUS IS FAILED)

Contents

- (1) Reference position return was executed when the following condition is not satisfied:
The CNC received one rotation signal at least one time when the axis is moving to the reference position at a speed higher than a speed equivalent to 128 pulses of position error amount (DGN3000).
- (2) After turning on the absolute pulse coder for the first time, reference position return was performed, either manually or with G28, before establishing the position for the pulse coder. A normal reference position thus could not be obtained.

Countermeasures

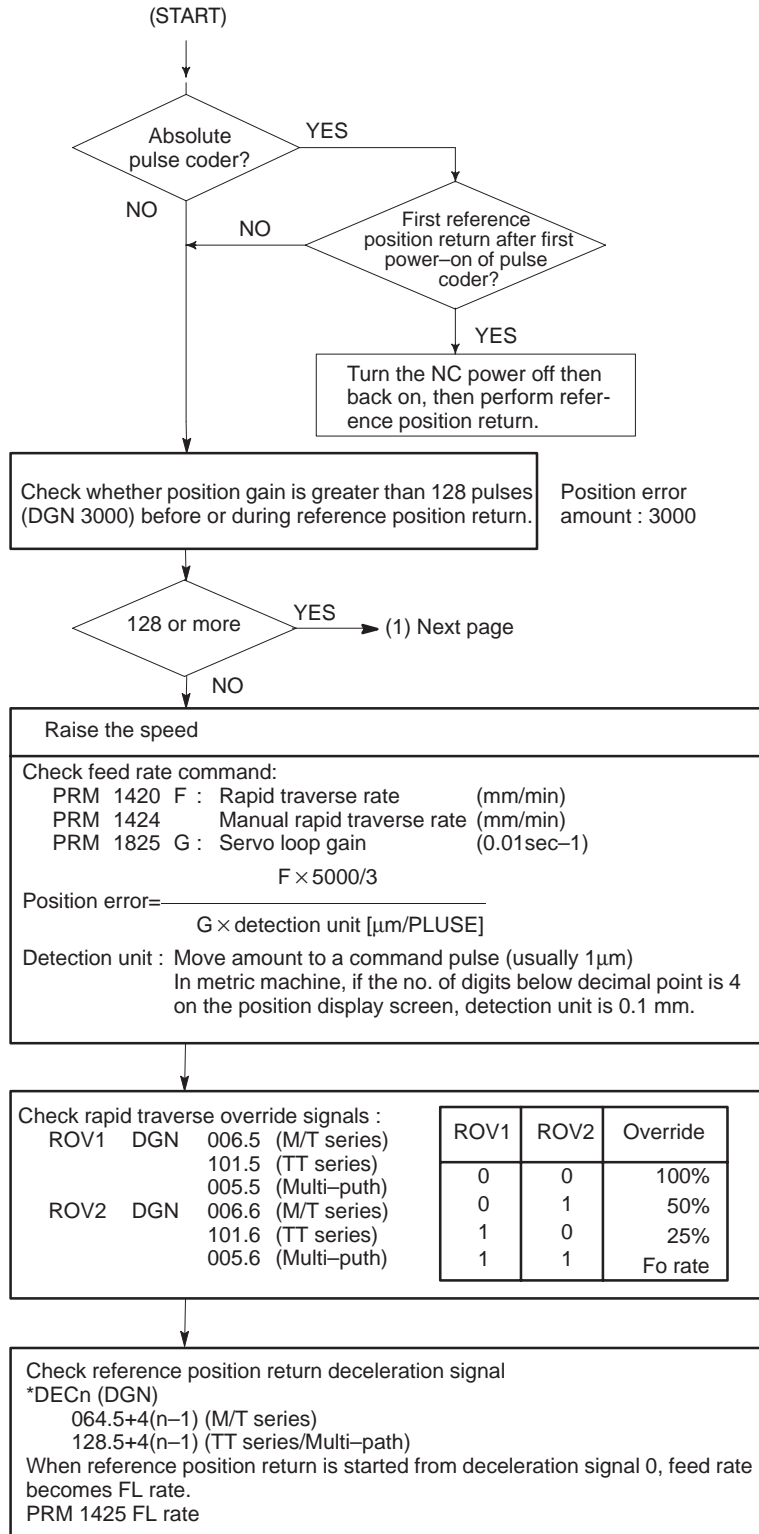

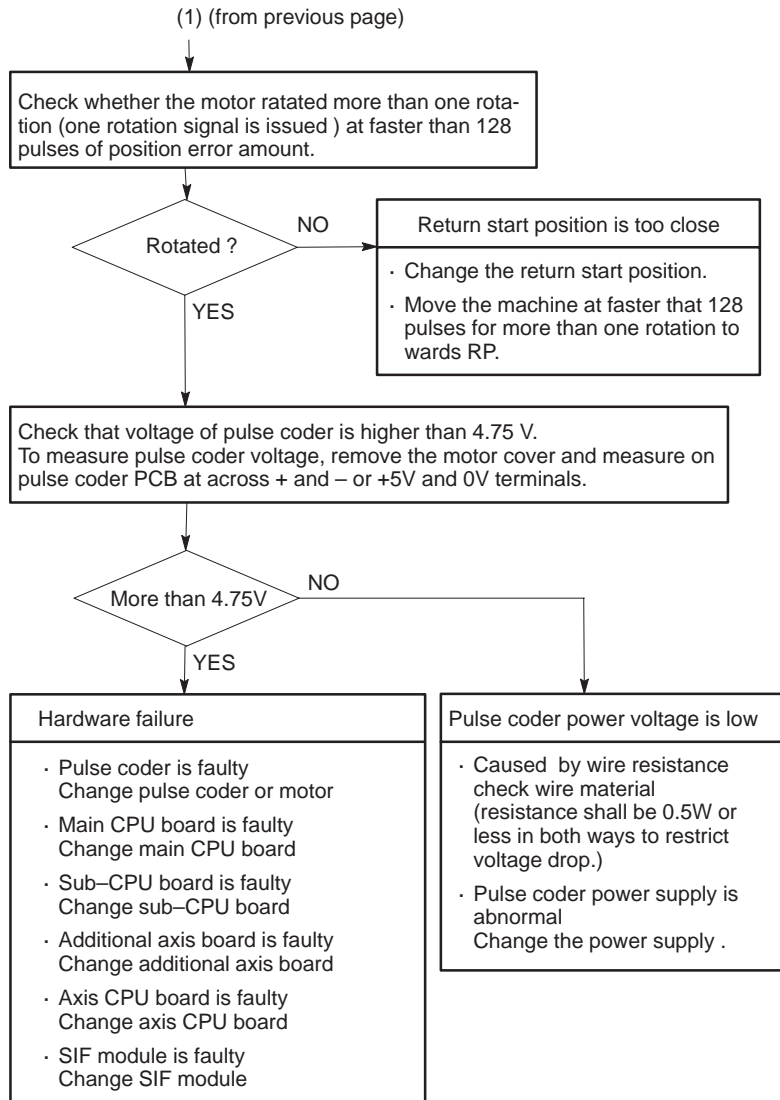
**CAUTION**

- 1 After the pulse coder or motor is exchanged, reference position or machine's standard point may be different from former one. Please set it correctly.
- 2 When the main board is exchanged, all the data stored in memory is lost. Reset all the NC data again, referring to the Chapter 3.

NOTE

A speed more than 128 pulses is required because if speed is lower than this, one-rotation signal does not function stably, causing improper position detection.

5.12 ALARM OT32 (NEED ZRN (ABS PDR))

Remedies

- When reference position return function is present

Absolute position data in the absolute pulse coder was lost.
(This alarm will be generated when absolute pulse coder is exchanged or position feedback signal cable of the absolute pulse coder is disconnected).

Machine position must be memorized using the following method:

- (1) Execute manual reference position return only for an axis for which this alarm was generated. When manual reference position return cannot be executed because of another alarm, set parameter 1815#5 to 0 and release the alarm and perform manual operation.

- (2) Press  key at the end of reference position return to release the alarm.

- When reference position return function is not present

Execute dogless reference position setting to memorize the reference position.

- When serial pulse coder is changed

Since the reference position is different from the former one, change the grid shift value (PRM 1850) to correct the position.

Related parameters

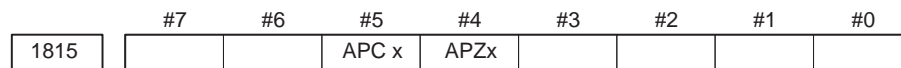

#5 (APCx) 0 : Position detector is incremental pulse coder.
1 : Position detector is absolute pulse coder.

#4 (APZx) Reference position of absolute pulse coder is :
0 : not established
1 : established

System configuration

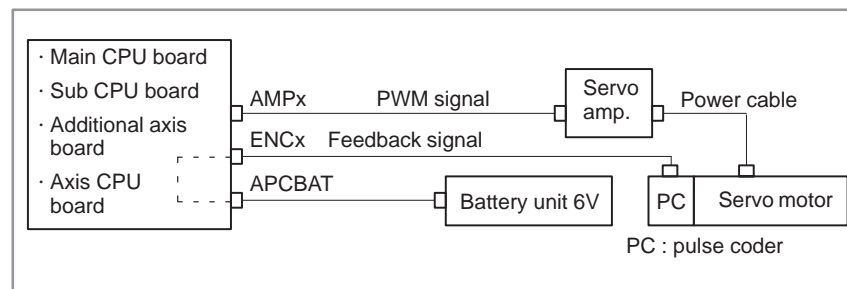

5.13 ALARM SV101 (DATA ERROR (ABS PCDR))

Absolute pulse coder, cable or servo module is faulty.

Points

Check the details of the error using the CNC diagnostic function.
The diagnostic number for each axis is obtained as follows:

$$3018 + (n - 1) \times 20 \quad (n: \text{axis number} = 1, 2, 3, \dots)$$

Causes and Remedies

	#7	#6	#5	#4	#3	#2	#1	#0
Diagnostic	APMVAL	APPER	APFER	APTER	APCER		APPLSM	

- (1)#1 (APPLSM) A mispulse alarm has been issued.
⇒ Associate the reference position with absolute position detection.
- (2)#3 (APCER) A communication error has occurred during data transfer.
#4 (APTER) A time-over error has occurred during data transfer.
#5 (APFER) A framing error has occurred during data transfer.
#3 (APPER) A parity error has occurred during data transfer.
- ⇒ (i) If the error recurs, identify the error by applying the above diagnostic. If the diagnostic always indicates the same error, replace the feedback cable, servo interface module, or pulse coder.
- (ii) If the diagnostic does not always indicate the same error, or if any other failure is detected, the error may have been caused by external noise.
- (3)#7 (APMVAL) An excessive motor shift alarm has been issued.
This alarm is issued if the machine is shifted by a large amount, exceeding 24000 detection unit pulses, upon power-on.
⇒ The machine must be prevented from shifting upon power-on.

NOTE

If the feedback cable, servo interface module, or pulse coder is replaced, the reference position and machine zero point will differ from those before replacement. Perform adjustment and setting as necessary after replacement.

5.14 ALARM OT34 (BATTERY ZERO (ABS PCDR))

This alarm is issued when the battery for the absolute pulse coder has failed (its voltage has dropped to 0 V). Absolute position data is lost when the battery is replaced. After replacing the battery, therefore, perform reference position return to re-set the machine position.

For the battery boxes connected to the following connectors, replace that battery which corresponds to the axis for which an alarm has been issued, as described in Section 2.8.2.

Remedies

CAUTION

- 1 Change the batteries while power of NC is supplied.
- 2 Do not change the battery (memory backup battery) for the control unit.
- 3 The CNC is constantly monitoring the state of each battery. Once the voltage of a battery has fallen below the rated value, a yellow blinking "BAT" indication appears at the bottom right of the CRT. As soon as this indication appears, use the diagnostic screen to identify the low-voltage battery, then replace that battery.

Diagnostic	#7	#6	#5	#4	#3	#2	#1	#0	
240	BATL	PBATL							(M/T series)
Diagnostic	#7	#6	#5	#4	#3	#2	#1	#0	
320	BATL						PBATL		(TT series)
224									(Multi-path)

PBATL Indicates that the voltage of the battery for the absolute pulse coder has fallen below the rated value. Replace the battery as described above.

BATL Indicates that the voltage of the backup battery, used to maintain the contents of the memory containing command programs and parameters, has fallen below the rated value. Replace the battery on the control unit.

5.15
ALARM SV110
(PULSE CODER
ALARM1 (SERIAL))

The serial pulse coder or feedback cable has been found to be defective.

Points

Check the details of the alarm using the CNC diagnostic function.

- When diagnostic number 0202 shows 1

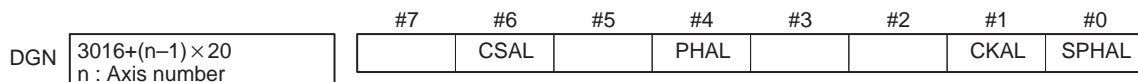

- #6 (CSAL) Check sum alarm has generated.
- #4 (PHAL) Phase data abnormal alarm has generated.
- #1 (CKAL) Clock alarm has generated.
- #0 (SPHAL) Soft phase data abnormal alarm has generated.
 - 1 Check the contents using the above diagnostic function if the alarm generates repeatedly. If diagnostic data is the same, serial pulse coder may be faulty. ⇒Refer to Caution
 - 2 When diagnostic result does not the same, or other abnormality is detected, an external noise may be generated.

CAUTION
 Reference position and machine's standard position are different from the ones before, adjust and set them correctly.

5.16
ALARM SV114
(ABNORMAL REV
DATA)

Erroneous rotation speed count data from the serial pulse coder has been detected.

- 1 If the alarm generates repeatedly, serial pulse coder may be faulty. ⇒Refer to Caution
- 2 When diagnostic result does not the same, or other abnormality is detected, an external noise may be generated.

CAUTION
 Reference position and machine's standard position are different from the ones before, adjust and set them correctly.

5.17 ALARM SV115 (ABNORMAL COMMUNICATION (SERIAL PCDR))

An error is generated in communication with serial pulse coder.

Points

Check the details by the diagnostic function of the CNC.

DGN	3017+(n-1)×20 n : Axis number	#7	#6	#5	#4	#3	#2	#1	#0
			CSA		PHA	RCA		CKA	SPHA

#7 (DTE) Data error has generated.

#6 (CRC) Serial communication error has generated.

#5 (STB) Stop bit error has generated.

1) **#7 (DTE)**:Response from serial pulse coder is absent.
(Causes)

- 1 Signal cable is disconnected
- 2 Serial pulse coder is faulty. ⇒ See Caution.
- 3 +5V to the serial pulse coder is lowered.

2) **#6 (CRC), #5 (STB)**:Serial communication is in faulty
(Causes)

- 1 Signal cable is disconnected.
- 2 Serial pulse coder is faulty ⇒ See Caution.
- 3 Main CPU board, sub CPU board, additional axis board, or axis CPU board (multiple axis/multi-path), is faulty ⇒ See Note

CAUTION

After the serial pulse coder is changed, reference position or machine's standard point is different from the one before replacement. Therefore reset and adjust it again.

NOTE

All the data stored in memory is lost when the main board is changed. Set NC data again, referring to "chapter 3 data input/output".

5.18 ALARM SV23 (SV OVER LOAD)

Amplifier or overheat of motor is detected.

Points

Confirm the detail by the diagnostic function of CNC.

DGN	3014+(n-1) × 20 n : Axis number	#7	#6	#5	#4	#3	#2	#1	#0
		OVL							

#7 (OVL) 1 OVERLOAD ALARM is displayed.

Check details of alarms.

DGN	3015+(n-1) × 20 n : Axis number	#7	#6	#5	#4	#3	#2	#1	#0
		ALD							
		↓							
		1	Overheat of servo motor						
		0	Overheat of servo amplifier						

● SVM fan alarm

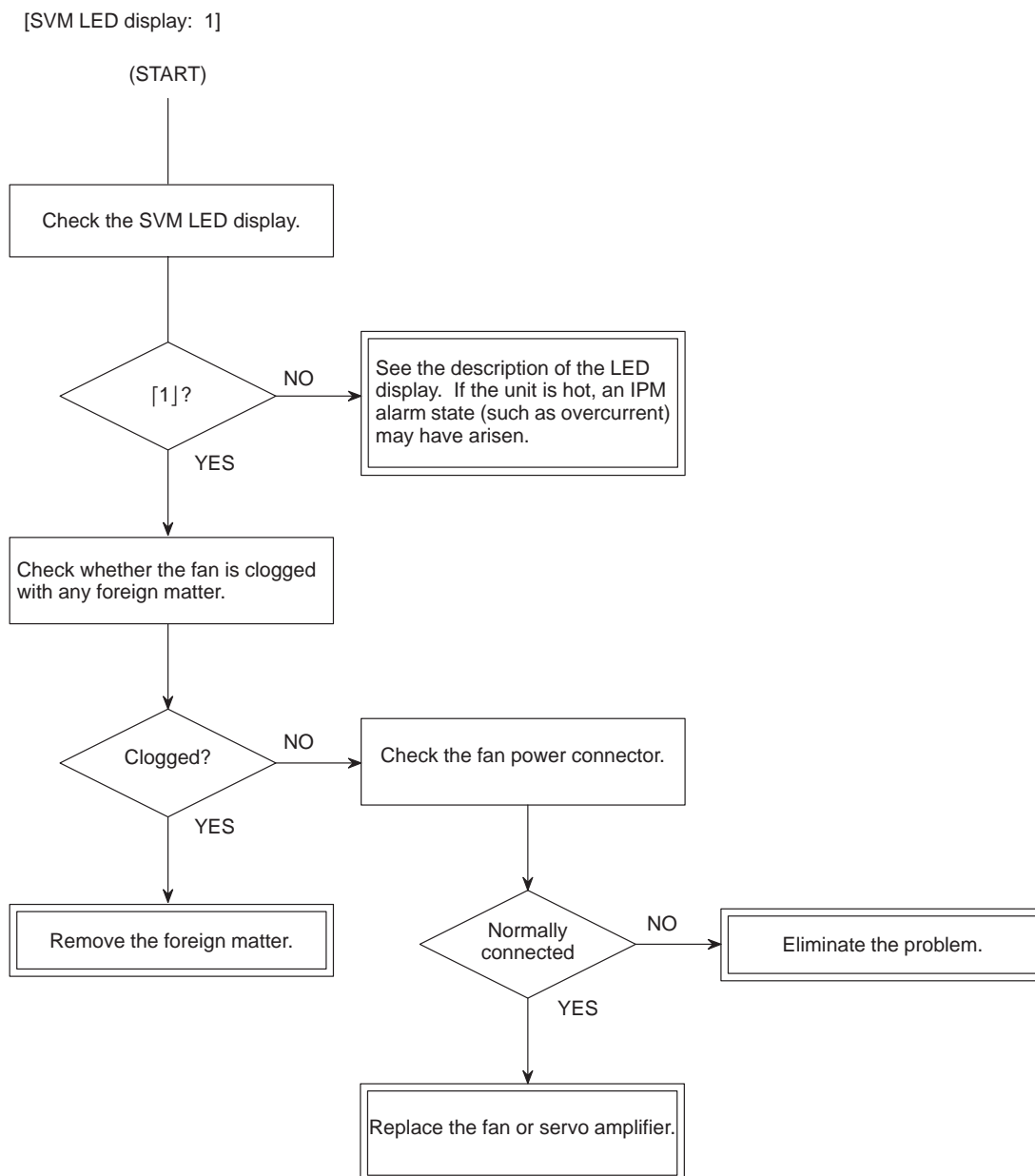

5.19 ALARM 700 (OVERHEAT AT CONTROL SIDE)

Remedies

Because an ambient temperature of the control unit becomes high, a thermostat mounted on the back panel of NC functions and informs an alarm.

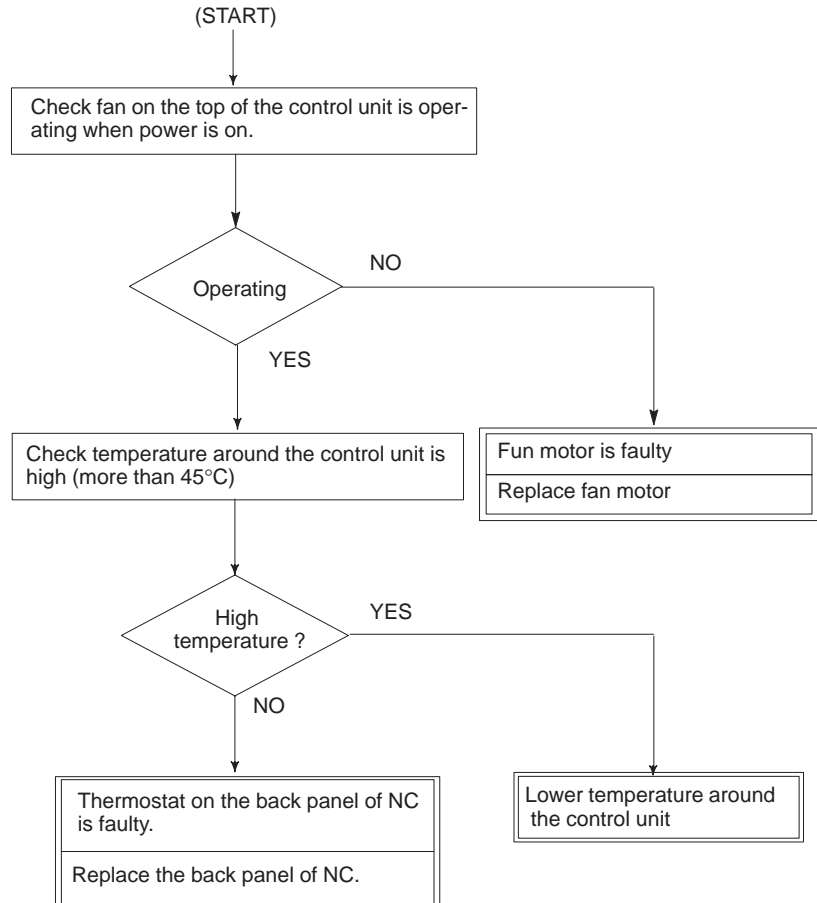

5.20 ALARM OT117 (SPINDLE SPEED FLUCTUATION DETECTION ALARM)

Remedies

Spindle speed changes abnormally due to load.

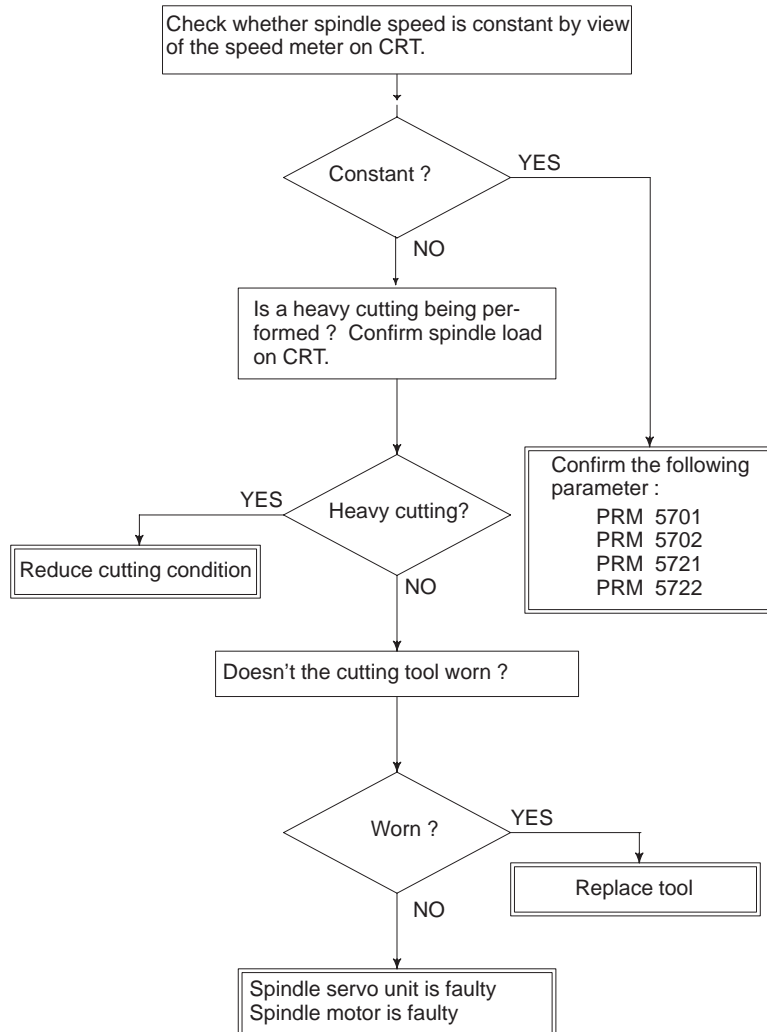

Remedies

PRM 5701 : A ratio of spindle speed at which actual spindle speed is regarded as arrived at a command spindle speed.

PRM 5702 : Spindle speed fluctuation ratio up to which the spindle speed fluctuation detection alarm is not issued.

PRM 5721 : Spindle speed fluctuation that is not regarded as the spindle speed fluctuation alarm.

PRM 5722 : Time when a spindle speed changed to when spindle speed fluctuation detection is started.

5.21 ALARM OT300 (SPINDLE SERIAL LINK CANNOT BE STARTED)

Alarm OT300 is issued when the spindle amplifier cannot be started normally in a system using a serial spindle.

Causes

- (1) Optical cable is in poor contact or spindle amplifier power is off.
- (2) When display of spindle amplifier shows SU-01 or an alarm other than AL-24 is displayed, power to the NC is turned on.
In this case, this alarm usually occurs when the NC's power is turned off while the serial spindle is operating. Turn off the power of serial spindle once, then turn it on and starts the system.
- (3) Combination of hardware is wrong.
- (4) When the 2nd spindle is at the state of (1) to (3).
When the 2nd spindle is used, parameter is set as follows :
Bit 1 of parameter no.5606 is 1: No. of serial spindles connected is 2.
- (5) Parameter setting is failed.

• Diagnosis

	#7	#6	#5	#4	#3	#2	#1	#0
1500	SALMI		CALM	CMER	CER	SNER	FRER	CRER

Information in the LSI chip for the Serial Interface Controller (SIC)

- CPER** 1 : CRC error (warning)
- FRER** 1 : Framing error (warning)
- SNER** 1 : Wrong transmission/reception station
- CER** 1 : Receive error
- CMER** 1 : No reply during automatic scanning
- CALM** 1 : Communication alarm in the spindle amplifier
- SALMI** 1 : System alarm in the spindle amplifier

	#7	#6	#5	#4	#3	#2	#1	#0
1501							SICTYP	

Information in the LSI chip for the Serial Interface Controller (SIC), Printed circuit board (P), and others

- SICTYP** The conditions for controlling a serial spindle are:
0 : Not satisfied.
1 : Satisfied.

	#7	#6	#5	#4	#3	#2	#1	#0
1502			SREQ1	SSTB1				

NC internal processing sequence information and spindle status 1

- SSTB** 1 : NC ready to communicate but the first spindle is not
- SREQ** 1 : NC operable but the first spindle is requesting a parameter

	#7	#6	#5	#4	#3	#2	#1	#0
1503	SLES2		SREQ2	SSTB2	SSPRM2	SNCRRM2	SNOTC2	

NC internal processing sequence information and spindle status 2

SNOTC2 1 : No SIC2–LSI connected to the serial line

SNCRRM2 1 : NC SIC2–LSI error (parameter check error)

SSPRM2 1 : NC SIC2–LSI communication busy high, or spindle SIC2–LSI error (parameter check error)

SSTB2 1 : NC ready to communicate but the second spindle is not

SREQ2 1 : NC operable but the second spindle is requesting a parameter

SLES2 1 : More spindle amplifiers connected than the number of spindles specified by parameter

Check the details of the alarm according to diagnostic Nos. 1500 to 1503.

(1) 1500#2 (SNER), 1500#3 (CER), 1500#4 (CMER), 1500#5 (CALM), 1500#7 (SALMI)

An error has occurred during communication with the spindle amplifier.

↓

This error may occur as a secondary error for an error indicated by diagnostic No. 1501, 1502, or 1503. If another error has occurred, first apply appropriate countermeasures for that error.

↓

If only this error has occurred, apply countermeasures against noise.

↓

If the above fails to clear the error, the spindle module, communication cable, or spindle amplifier may be faulty.

(2) 1501#1 (SICTYP) = 0

The conditions for controlling a serial spindle are not satisfied.

↓

Check that a serial spindle module is installed.

Check that the serial spindle option parameters are set.

Check that parameter No. 5606 is set so that a serial spindle is to be used.

(3) 1502#4(SSTB1), 1503#4(SSTB2), 1502#5(SREQ1), 1503#5(SREQ2)

Synchronization with a serial spindle is not established.

↓

Collate the number of connected serial spindles specified with parameter No. 5606, with the number of spindles actually connected.

↓

If the numbers match, the spindle module, communication cable, or spindle amplifier may be faulty.

(4) 1503#1 (SNOTC2)

The spindle amplifier cannot be recognized.



Check the state of the communication cable.



If no problem is identified, the spindle module, communication cable, or spindle amplifier may be faulty.

(5) 1503#2 (SNCRM2)

An error has occurred during testing of the spindle module.



The spindle module may be faulty.

(6) 1503#3 (SSPRM2)

An error has occurred during testing of the entire spindle control system including the spindle amplifier.



This error may occur as a secondary error for another error. If another error has occurred, first apply appropriate countermeasures for that error.



If only this error has occurred, the spindle module, communication cable, or spindle amplifier may be faulty.

(7) 1503#7 (SLES2)

The number of spindles actually connected is less than the number of spindles specified with a parameter.



Collate the number of connected serial spindles, specified with parameter No. 5606, with the number of spindles actually connected.



If the numbers match, the spindle module, communication cable, or spindle amplifier may be faulty.

APPENDIX

A MAINTENANCE PARTS

Maintenance parts can be classified into two types: repairable parts and consumable parts. Repairable parts are covered in Section 2.6. This appendix lists consumable maintenance parts (fuses, batteries, fans, keyboards, etc.).

A.1 MAINTENANCE PARTS FOR THE FANUC

Series 15-B	330
-------------------	-----

A.1 MAINTENANCE PARTS FOR THE FANUC SERIES 15-B

Maintenance parts (consumables)

Consumable maintenance parts are not repaired. In the event of their being damaged, they are discarded and replaced.

Name		Ordering code	Drawing number	Remarks	
Fan motor	For two-slot case	—	A90L-0001-0378	One fan motor for every two slots	2.4W
	For one-slot case	—	A90L-0001-0385#A	Two fan motors for a three-slot cabinet	1.7W
Battery		A02B-0120-K106	A98L-0031-0007	For power supply of conventional type	
		A02B-0200-K103	A98L-0031-0012	For CE marking compatible power supply	
Power fuse	For AI power supply (conventional type)	A02B-0120-K102	A60L-0001-0245#GP75	F1(7.5A)	
			A60L-0001-0245#GP75	F2(7.5A)	
			A60L-0001-0075#3.2	F3(3.2A)	
			A60L-0001-0046#5.0	F4(5AS)	
			A60L-0001-0290#LM03	F5(0.3A)	
	For BI power supply (conventional type)	A02B-0120-K103	A60L-0001-0245#GP100	F1(10A)	
			A60L-0001-0245#GP100	F2(10A)	
			A60L-0001-0075#5.0	F3(5A)	
			A60L-0001-0046#5.0	F4(5AS)	
			A60L-0001-0290#LM03	F5(0.3A)	
	For AI power supply (CE marking compatible)	A02B-0200-K100	A60L-0001-0245#GP75	F1(7.5A)	
			A60L-0001-0075#3.2	F3(3.2A)	
			A60L-0001-0046#5.0	F4(5AS)	
	For BI power supply (CE marking compatible)	A02B-0200-K101	A60L-0001-0245#GP100	F1(10A)	
			A60L-0001-0075#5.0	F3(5A)	
			A60L-0001-0046#5.0	F4(5AS)	
	For CE marking compatible operator's panel connection unit	A02B-0163-K111	A60L-0001-0175#3.2A	FU1(3.2A) for A16B-2202-073X	
			A60L-0001-0290#LM50	FU2(5.0A) for A16B-2202-073X	
	For connection unit	A02B-0072-K103	A60L-0001-0046#1.6	FS1(1.6A) for A20B-1005-0310	
	For multi-axes input unit	A02B-0162-K111	A60L-0001-0290#LM10	For A14B-0076-B401	
A60L-0001-0175#1.0A					
A02B-0162-K112		A60L-0001-0290#LM10	For A14B-0076-B402		
		A60L-0001-0175#2.0A			

Maintenance parts

- **Maintenance parts (consumables)**

Consumable maintenance parts are not repaired. In the event of their being damaged, they are discarded and replaced. In the following table, keyboards, key sheets, and display devices are handled as consumables.

Name		Unit drawing number	Key sheet	Keyboard	Display device	Re-remarks		
9" CRT/MDI unit	Monochrome, vertical type	A02B-0162-C041	A02B-0162-K101	A86L-0162-0196/02	A61L-0001-0093			
		A02B-0162-C044						
		A02B-0163-C244	A02B-0163-K101					
		A02B-0163-C444	A02B-0163-K121					
	Monochrome, horizontal type	A02B-0162-C042	A02B-0162-K101					
		A02B-0162-C045						
		A02B-0163-C245	A02B-0163-K101					
		A02B-0163-C445	A02B-0163-K121					
	Color, vertical type	A02B-0162-C051	A02B-0163-K101				A61L-0001-0095	
		A02B-0162-C054						
	Color, horizontal type	A02B-0162-C052						
		A02B-0162-C055						
9" small CRT/MDI unit	Mono-chrome	M	A02B-0162-C101	A02B-0162-K102	A86L-0001-0157	A61L-0001-0093		
			A02B-0163-C301				A02B-0163-K102	
		T	A02B-0162-C102	A02B-0162-K103				
			A02B-0163-C302	A02B-0163-K103				
	Color	M	A02B-0162-C103	A02B-0162-K102			A61L-0001-0093	
			A02B-0162-C104	A02B-0162-K103			A61L-0001-0095	
9" PDP/MDI unit	Monochrome, horizontal type	A02B-0162-C062	A02B-0162-K104	A86L-0001-0196/02	A61L-0001-0116			
		A02B-0162-C065						
		A02B-0163-C265	A02B-0163-K104			A61L-0001-0116/S		
		A02B-0163-C465	A02B-0163-K124					
9" small PDP/MDI unit	Mono-chrome	M	A02B-0162-C105	A02B-0162-K105	A61L-0001-0116			
			A02B-0163-C305		A02B-0163-K105	A61L-0001-0116/S		
		T	A02B-0162-C106	A02B-0162-K106	A61L-0001-0116			
			A02B-0163-C306	A02B-0163-K106	A61L-0001-0116/S			

Name		Unit drawing number	Key sheet	Keyboard	Display device	Re- marks			
9.5" LCD/ MDI unit	Color, vertical type	A02B-0162-C131	These units have a membrane-type keyboard and use no key sheet.	A86L-0001-0197#02A	A61L-0001-0138				
		A02B-0163-C331		A86L-0001-0197#02AR					
		A02B-0162-C141		A86L-0001-0197#02A					
		A02B-0163-C341		A86L-0001-0197#02AR					
		A02B-0162-C133		A86L-0001-0197#03B					
		A02B-0163-C333		A86L-0001-0197#03BR					
	Color, horizontal type	A02B-0162-C132		A86L-0001-0195#02A					
		A02B-0163-C332		A86L-0001-0195#02AR					
		A02B-0162-C142		A86L-0001-0195#02A					
		A02B-0163-C342		A86L-0001-0195#02AR					
		A02B-0162-C132		A86L-0001-0195#08B					
		A02B-0163-C332		A86L-0001-0195#08BR					
		10" LCD/ MDI unit		Color, vertical type		A02B-0162-C071	A86L-0001-0197#02A	A61L-0001-0123	
						A02B-0162-C073	A86L-0001-0197#03B		
Color, horizontal type	A02B-0162-C072		A86L-0001-0195#02A						
	A02B-0162-C074		A86L-0001-0195#08B						
10.4" LCD/ MDI unit, graphic function built-in type	Color, vertical type	A02B-0163-C371	A86L-0001-0197#02AR	A61L-0001-0163					
		A02B-0163-C571	A86L-0001-0197#02AS						
	Color, horizontal type	A02B-0163-C372	A86L-0001-0195#03BR						
		A02B-0163-C572	A86L-0001-0195#03BS						

Maintenance parts

- **Maintenance parts (consumables)**

Consumable maintenance parts are not repaired. In the event of their being damaged, they are discarded and replaced. In the following table, keyboards, key sheets, and display devices are handled as consumables.

Name		Unit drawing number	Key sheet	Keyboard	Display device	Remarks			
10.4" LCD/MDI unit, for MMC-IV	Color, vertical type	A02B-0163-C381		A86L-0001-0197#02AR	A61L-0001-0163				
		A02B-0163-C581		A86L-0001-0197#02AS					
	Color, horizontal type	A02B-0163-C382		A86L-0001-0195#03BR					
		A02B-0163-C582		A86L-0001-0195#03BS					
10" PDD/MDI unit	Monochrome, vertical type	A02B-0162-C081		A86L-0001-0197#02A	A61L-0001-0126				
	Monochrome, horizontal type	A02B-0162-C082		A86L-0001-0195#02A					
14" CRT/MDI unit	Color, vertical type	A02B-0162-C091	These units have a membrane-type keyboard and use no key sheet.	A86L-0001-0197#02A	A61L-0001-0094#A				
		A02B-0162-C093		A86L-0001-0197#03B					
		A02B-0162-C121		A86L-0001-0197#02A					
		A02B-0163-C321		A86L-0001-0197#02AR	A61L-0001-0096				
		A02B-0163-C323		A86L-0001-0197#03BR					
		A02B-0163-C523		A86L-0001-0197#03BS					
	Color, horizontal type	A02B-0162-C092		A86L-0001-0194#02A	A61L-0001-0094#A				
		A02B-0162-C094		A86L-0001-0194#04B					
		A02B-0162-C122		A86L-0001-0194#02A					
		A02B-0163-C322		A86L-0001-0194#02AR	A61L-0001-0096				
		A02B-0163-C324		A86L-0001-0194#04BR					
		A02B-0163-C522		A86L-0001-0194#02AS					
		Separate type CRT unit		Monochrome	A02B-0162-C046	No keyboard mounted		A61L-0001-0093	
				Color	A02B-0162-C056		A61L-0001-0095		
Separate type PDP unit	Monochrome	A02B-0162-C066	A61L-0001-0116						
		A02B-0163-C268	A61L-0001-0116/S						
Separate type 10.4" LCD unit, graphic function built-in type	Color	A02B-0200-C150		A61L-0001-0163					
Separate type 9.5" STN unit, graphic function built-in type	Monochrome	A02B-0222-C110		A61L-0001-0154					

Name		Unit drawing number	Key sheet	Keyboard	Display device	Remarks		
Separate type MDI unit	For CRT	A02B-0162-C111	A02B-0162-K101	A86L-0001-0196/02	No display device mounted	Specify any of these parts when using the separate-type 9" CRT unit.		
		A02B-0162-C112						
		A02B-0163-C312	A02B-0163-K101					
		A02B-0163-C313	A02B-0163-K121					
	For PDP	A02B-0162-C111	A02B-0162-K104			A86L-0001-0246	No display device mounted	Specify any of these parts when using the separate-type 9" PDP unit.
		A02B-0162-C112						
		A02B-0163-C312	A02B-0163-K104					
		A02B-0163-C313	A02B-0163-K124					
	For LCD	A02B-0163-C316	A02B-0163-K108	A86L-0001-0246	No display device mounted	Specify any of these parts when using the separate-type 10.4" LCD unit.		
		A02B-0163-C318	A02B-0163-K128					
		A02B-0163-C317	A02B-0163-K108					
		A02B-0163-C319	A02B-0163-K128					

* The "key sheet" stated here includes the key sheet for soft keys.

B BOOT SYSTEM

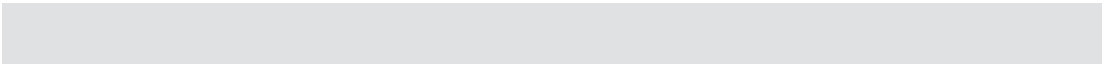

B.1	OVERVIEW	336
B.2	SCREEN CONFIGURATION AND OPERATING PROCEDURE	341
B.3	ERROR MESSAGES AND REQUIRED COUNTERMEASURES	355
B.4	SYSTEM ALARMS AND REQUIRED COUNTERMEASURES	357

B.1 OVERVIEW

The Series 15-B boot system is designed to load the CNC system software (from flash memory into DRAM) and to start the CNC software in preparation for the execution of the CNC software. The boot system has the following functions related to the maintenance of the Series 15-B system.

- (1) Storing a file into flash memory
 - Reads a file into flash memory from an MS-DOS-formatted memory card conforming to the JEIDA V4.1 standard.
- (2) Confirming the series and edition of a file in flash memory and deleting a file from flash memory
- (3) Saving or restoring battery backup files of parameters, programs, and the like (SRAM area) to or from a memory card in batch mode
- (4) Saving a file from flash memory onto a memory card
- (5) Formatting a memory card

This appendix describes the screens displayed upon the activation of the boot system, as well as those displayed by the functions described above and the corresponding operating procedures.

B.1.1 Power-up Processing Sequence Display

```

(1)  RAM TEST   : END
(2)  ROM TEST  : END XXXX X   ( ERROR ) dynamic stop
(3)  DRAM ID   : XXXX       ( ERROR ) dynamic stop
(4)  SRAM ID   : XXXX       ( PASS  )
(5)  FROM (CNC) : XXXX
(6)      (PMC) : XXXX       ( PASS  )
(7)  CNC DATA SEARCH : END   ( ERROR ) RESET key → SYSTEM MONITOR
(8)  LOADING CNC DATA

```

Description

- (1) : Result of the work RAM test. If an error occurs, the error status is not displayed here but is instead indicated by the LED (LED E1).
- (2) : Result of the boot ROM parity test. When the test ends normally, the series and edition are displayed. If an error occurs, the system stops.
- (3) : ID of the DRAM module mounted on the CNC module. If the ID cannot be recognized, ERROR is displayed, and the system stops.
- (4) : ID of the high-speed SRAM module mounted on the CNC module. If the ID cannot be recognized, PASS is displayed. The system assumes that the high-speed SRAM is not mounted.

- (5) : ID of the flash ROM module mounted on the CNC module. If the ID cannot be recognized, the status is indicated by the LED (LED 02).
- (6) : ID of the flash ROM module mounted on the PMC module. If the ID cannot be recognized, PASS is displayed. The system assumes that the module is not mounted.
- (7) : Result of the validity check made for the CNC basic software in flash ROM. This validity check is made based on the data recognition information only. A parity check is executed as part of the CNC power-up processing.
If an error is detected, the SYSTEM MONITOR screen can be selected by pressing the  key.
- (8) : Indicates that the CNC basic software is being transferred from the flash ROM module to DRAM (SRAM). (The transfer takes about 10 seconds.)

LED

	1	2	3	4
LED E1	×	□	□	□
	1	2	3	4
LED 02	□	■	□	□



× : Blinking □ : Not lit ■ : Lit

B.1.2 Starting the Boot System





When the system starts normally, the boot system automatically transfers a file from flash memory to DRAM. The user is normally not aware of the boot system. The boot system should be operated from the menu screen when maintenance is performed or when no file is found in flash memory.

Selecting SYSTEM MONITOR



SYSTEM MONITOR is selected in either of the following two ways:

- (1) Pressing the  key while CNC DATA SEARCH: ERROR is displayed
- (2) Turning the power on while holding down the page up/down keys ( )

NOTE

When using a 9" small MDI unit, turn the power on while holding down cursor keys ( ) instead of the page up/down keys ( ). With the 9" small MDI unit, set the keyboard as described below, before selecting SYSTEM MONITOR.

Setting the 9" small MDI unit

When the following display appears, select the MDI unit to be used. To use a lathe-system MDI unit, press the  key. To use a machining-center MDI unit, press the  key. Once the MDI has been set, SYSTEM MONITOR is selected.

SET MDI KEYBOARD TYPE

F15 T/TT — PUSH INPUT KEY

F15 M — PUSH CANCEL KEY

B.1.3 System File and User File

The boot system manages the files in flash memory by dividing them into two large categories: system files and user files. These two file types differ as described below:

- **System files**
- **User files**

Files of the CNC or servo control software provided by FANUC

User-created files of a PMC sequence program (ladder), P-CODE macro program, or the like

- Files that can be stored in flash memory

Flash memory files

File name	Description	CNC basic software
NC BASIC	system	CNC basic software
NC SUB CPU	system	CNC basic software (for system with sub-CPU)
AXIS CPU	system	CNC basic software (for multiaxis system)
OPTIONA1	system	CNC option installation software A1
OPTIONA2	system	CNC option installation software A2
OPTIONA3	system	CNC option installation software A3
OPTIONA4	system	CNC option installation software A4
SUBOPTS1	system	CNC option installation software S1
HELP MSG	system	CNC help message software
DG SERVO	system	Digital servo software
MCR-CMPA	system	Macro compiler software
MCR-CMPB	system	Macro compiler software (for system with sub-CPU)
PCD 256A	user	P-code macro of 256K bytes
PCD 512A	user	P-code macro of 512K bytes
PCD 256M	user	P-code macro of 256K bytes (for system with sub-CPU)
PCD 512M	user	P-code macro of 512K bytes (for system with sub-CPU)
PMC-NA0A	user	PMC cassette A (for PMC-NA)
PMC-NA0B	user	PMC cassette B (for PMC-NA)
PMC-NA0C	user	PMC cassette C (for PMC-NA)
PMC-NA0D	user	PMC cassette D (for PMC-NA)
PMC-NA0E	user	PMC cassette E (for PMC-NA)
PMC-NB0A	user	PMC cassette A (for PMC-NB)
PMC-NB0B	user	PMC cassette B (for PMC-NB)
PMC-NB0C	user	PMC cassette C (for PMC-NB)
PMC-NB0D	user	PMC cassette D (for PMC-NB)
PMC-NB0E	user	PMC cassette E (for PMC-NB)

NOTE

The above file names are subject to change without notice.

B.1.4 Memory Cards for Use with the Boot System

The table below lists the functions and corresponding memory card types that can be used. Cards must be of TYPE 1 or 2 as defined in the Personal Computer Memory Card International Association (PCMCIA) standard, version 2.0 or later, or the Japan Electronic Industry Development Association (JEIDA) standard, version 4.1 or later. The format conforms to the DOS FAT file system.

The memory card has a maximum storage capacity of 32M bytes.

	SRAM card	Flash memory card	
		Supported (*1)(*2)	Not supported
File read	○	○	○
Card format	○	○	×
File write	○	○	×
File list	○	○	○

NOTE

- 1 The following flash memory cards are supported:
 - Intel Series 2 flash memory card (or equivalent)
 - Intel Series 2+ flash memory card (or equivalent)
 Both types require the use of attribute memory. For other flash memory cards, see the rightmost column “Not supported” in the table shown above.
 - The ATA flash memory card cannot be used.
 - With the PMC-NA, the flash memory card is used only for the boot system.
- 2 Some flash memory cards, written using the memory card interface built into a personal computer, may use a format other than that indicated above. Such memory cards cannot be used.

B.2 SCREEN CONFIGURATION AND OPERATING PROCEDURE

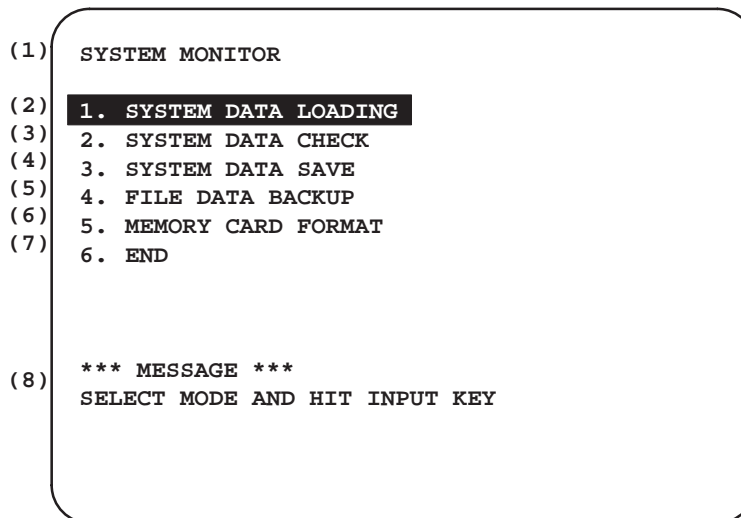

When the boot system starts, the main menu appears first. The main menu is described below:

- Main menu



- (1) : Title
- (2) : Loading ROM data into flash ROM memory from a memory card
- (3) : Confirming the ROM data stored in flash ROM memory
- (4) : Writing the ROM data stored in flash ROM memory to a memory card
- (5) : Batch saving or restoration of battery backup file data by using a memory card
- (6) : Formatting a memory card
- (7) : Ending SYSTEM MONITOR
- (8) : Message field
(For example, a quick operation guide may be displayed.)

- Operating procedure

Press a cursor key ( ) to choose the desired processing.

Position the cursor to a desired function, then press the  key.

- Basic operation flow

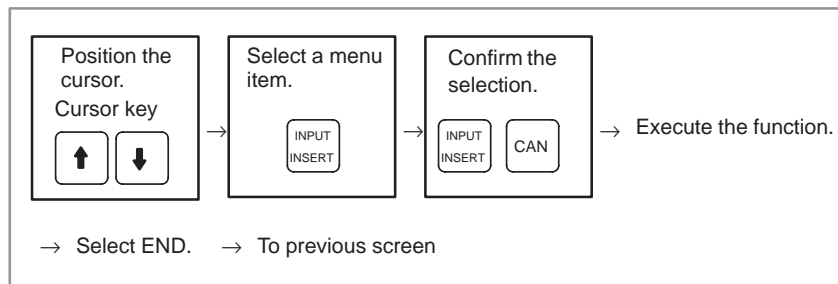

B.2.1 SYSTEM DATA LOADING Screen

- Description
- Screen configuration

A system file or user file is loaded into flash memory from a memory card.



```
(1)  SYSTEM DATA LOADING
(2)  FILE DIRECTORY
(3)  1. xxxx.yyy
      2. aaa.bbb
      3. ccc.ddd
      4. eeee.fff
      (4) END
(5)  *** MESSAGE ***
      SELECT FILE AND HIT INPUT KEY
```

- (1) : Title
- (2) : Memory card directory display
- (3) : ROM file name
- (4) : Ending the processing
- (5) : Message field
(For example, a quick operation guide may be displayed.)

- Operating procedure

Position the cursor to the file to be loaded by pressing a cursor key ()

(  ). Then, press the  key.

The OK? INPUT/CANCEL message appears in the message field. To load the file, press the  key. To cancel the selection, press the  key.

- **Status display during loading**

While a file is being loaded, the following statuses are displayed:

- (1)LOADING FROM IC-CARD : Data is being loaded from a memory card.
- (2)TEST DEVICE : The flash ROM module is undergoing a device test.
- (3)PROGRAM AND VERIFY : Data is being written to the flash ROM module.
- (4)PROGRAM COMPLETE : Writing to the flash ROM module has been completed.

Once loading has been completed, the HIT INPUT KEY message appears. Press the  key. Another file can be selected.

To terminate the processing, position the cursor to END, then press the  key. The main menu appears again.

- **Others**

- 1 Count display during file loading

While a file is being loaded, the address of the current access data is displayed.

```

*** MESSAGE ***

LOADING FROM MEMORY CARD.

ADDRESS 001: 000022FF ← The count is indicated.
(1)           (2)

```

- (1) : Unit number of the 128KB management unit in flash memory
- (2) : Relative address in the management unit

NOTE

The count display may stop for five or six seconds during loading. This occurs when data is read into an internal buffer from the memory card. Provided no error is displayed while the count stops, processing is being performed normally. Meanwhile, the LOADING FROM IC-CARD message appears.

B.2.2 SYSTEM DATA CHECK Screen

- **Description**

The files in flash memory are listed. The list indicates the number of 128KB management units in each file and the series and edition of the software.

A user file can be deleted from flash memory.

- **Screen configuration**

```
(1)  SYSTEM DATA CHECK
(2)  FILE DIRECTORY
(3)  1. OPTIONA2 ( 2)
      2. OPTIONA1 ( 2)
      3. DG SERVO ( 1)
      4. NC BASIC ( 8)
      (4) END
(5)  *** MESSAGE ***
      SELECT FILE AND HIT INPUT KEY
```

(1) : Title

(2) : Flash memory directory display





(3) : ROM file name. The number of management units used is indicated in parentheses.

(4) : Ending the processing

(5) : Message field

(For example, a quick operation guide may be displayed.)

- **Operating procedure**

ROM files in flash memory are listed together with the number of management units (128KB management units) used in each file. To check the detailed information such as the series and edition of a ROM file, press a cursor key (   ) to position the cursor to that file.

Then, press the  key. The ROM FILE CHECK screen, which contains detailed information, appears.

To end the processing, position the cursor to END, then press the  key. The main menu appears again.

Displaying detailed information

• Operating procedure

- 1 Select a file for which detailed information is required. For example, select 4 NC BASIC (8).
- 2 The management unit numbers of the selected file and the series and edition of each management unit are listed. After checking the displayed data, press the  key to return to the file selection screen.

```

(1) ROM FILE CHECK
(2) NC BASIC
(3) 1. xxxx 002 y zzz
    2. xxxx 001 y zzz
    3. xxxx 042 y zzz
    4. xxxx 041 y zzz
    5. xxxx 082 y zzz
    6. xxxx 081 y zzz
    7. xxxx 102 y zzz
    8. xxxx 101 y zzz
      ↑
      ROM number
(4) *** MESSAGE ***
    HIT INPUT KEY

```

- (1) : Title
- (2) : Name of the file to be checked
- (3) : ROM series, edition, and internal management unit number of each management unit (128K bytes)
- (4) : Message field
(For example, a quick operation guide may be displayed.)

xxxx : Series
 y : Edition
 zzz : Internal management unit number

• Others

- 1 Parity information of the system file and user file



System files named NC BASIC, DG SERVO, OPTIONA1, and the like in flash memory contain parity information in each management unit. If a non-ASCII-code character or @ is displayed in the file name field or parity field on the check screen, the flash ROM may have been destroyed. Alternatively, a destroyed file may have been loaded. Retry loading from the memory card. A user file such as PMC-NA0A or PCD256A has no parity information in each management unit. A non-ASCII-code character or @ in the series/edition information displayed for the user file does not indicate that the file has been destroyed.

Deleting a user file from flash memory



• Operating procedure

1 Select the SYSTEM DATA CHECK function of SYSTEM MONITOR. The files in flash memory are listed.

2 Position the cursor to the user file to be deleted. Then, press the  key.

When using the keyboard for the 9" small unit, press the  key instead of the  key.

3 The DELETE OK? message appears.

4 To delete the file, press the  key. To cancel the deletion, press the  key.

When the INPUT key is pressed, the corresponding file is deleted.

5 Once the file has been successfully deleted, the following message appears. Press the  key.

```
*** MESSAGE ***  
DELETE COMPLETE. HIT INPUT KEY.
```

• Others

1 User file deletion and system files

While user file deletion is being performed, the system files are protected so that they cannot be deleted by the user. User files are not protected.

The protected system files can be overwritten, however, by selecting SYSTEM DATA LOADING.

B.2.3 SYSTEM DATA SAVE Screen

- **Description**

A user file is written to a memory card from flash memory. A user file stored in flash memory can be saved to a memory card, but no system files can be saved.

- **Screen configuration**

```
(1)  SYSTEM DATA SAVE
(2)  FILE DIRECTORY
(3)  1. OPTIONA2 ( 2)
      2. DG SERVO ( 1)
      3. NC BASIC ( 8)
      4. PMC-NAOB ( 1)
      (4) END
(5)  *** MESSAGE ***
      SELECT FILE AND HIT INPUT KEY
```

(1) : Title

(2) : Flash memory directory display





(3) : ROM file name. The number of management units used is indicated in parentheses.



(4) : Ending the processing

(5) : Message field

(For example, a quick operation guide may be displayed.)

- **Operating procedure**

The ROM files in flash memory are listed together with the number of management units (128KB management units) in each file. Press a cursor key (   ) to position the cursor to the file to be saved to a memory card. Then, press the  key.

The INPUT FILE NAME (CAN: RESET) message appears in the message field. Enter the name of the desired file on the memory card, then press the  key. To abandon saving, press the  key.

To end the processing, position the cursor to END, then press the  key. The main menu appears again.

- **Others**

- 1 System files and user files on the SYSTEM DATA SAVE screen
The SYSTEM DATA SAVE screen enables the saving of user files only. System files cannot be saved.
- 2 Name of saved file
 - A file name must be specified in line with MS-DOS conventions. (Up to eight characters for the file name and up to three characters for the extension)
 - If a file already on the memory card has the same name as the specified file name, that file will be overwritten.

B.2.4 SRAM DATA BACKUP Screen

- **Description**

Data to be held while the CNC power is off (parameters, programs, etc.) can be saved to or restored from a memory card in batch mode.

- **Screen configuration**



Select FILE DATA BACKUP from the SYSTEM MONITOR main menu. The following screen appears.

```
(1)  FILE DATA BACKUP
(2)  1. STORE FILE (CNC → CARD)
(3)  2. LOAD FILE (CARD →CNC)
(4)  END
(5)  FILE SIZE   : 1M BYTE



(6)  *** MESSAGE ***
      SELECT MODE AND HIT INPUT KEY
```

- (1) : Title
- (2) : Batch saving of data
- (3) : Batch restoration of data
- (4) : Ending the processing
- (5) : File size of the system (displayed after processing is selected)
- (6) : Message field
(For example, a quick operation guide may be displayed.)

- **Operating procedure (outline)**

To execute the batch saving of a backup data file (file SRAM), select STORE FILE. To execute batch restoration, select LOAD FILE. To terminate the processing, select END. To select the processing, press a cursor key ( ) to position the cursor, then press the  key.

When the batch saving or restoration of a file is selected, the size of the system's backup RAM is displayed on the screen.

To execute the selected processing, press the  key. To cancel the processing, press the  key. (See the detailed description given below.)

NOTE

The backup data is saved to file FILEx.BAK, where x is a value of 1 to 4. The original data can be saved in up to four files. If a single memory card cannot hold all the original data, the data can be saved using up to four memory cards. Details of the operating procedure are described later. Before saving backup data, check that the memory card contains no FILEx.BAK files. The names of the files already on the memory card can be listed in the FILE DIRECTORY field of the SYSTEM DATA LOADING screen, as described in Section B.2.1.

** To save backup data, use a formatted memory card.

- **Saving data**

To execute the batch saving of backup data, perform the following steps:

- (1) Select the STORE FILE function on the initial screen.
- (2) When the SET IC CARD NO.1 & HIT INPUT KEY message appears in the message field, mount the first memory card. Then, press the

 key.

To cancel the processing, press the  key. The initial screen appears again.

- (3) While data is being saved, the STORE TO IC-CARD message blinks. Once saving has been completed, the STORE FILE COMPLETE and HIT INPUT KEY messages appear in the message field. When the

 key is pressed, the initial screen appears again.

If the first memory card cannot hold all the data to be saved, the SET IC/CARD NO.2 & HIT INPUT KEY message appears in the message field. Mount the second memory card without turning the power off, then press the  KEY.

To cancel the processing, press the  key. The initial screen appears again.

- (4) The backup data can be saved using up to four memory cards by performing step (3) repeatedly. If four memory cards cannot hold all the data, the FILE DATA SIZE ERROR and HIT INPUT KEY messages appear in the message field. When the  key is pressed, the initial screen appears again.

NOTE





Once batch saving starts, requests to replace the memory card are repeated until all the backup data has been normally saved (using up to four memory cards). To stop the processing, press the  key while the SET IC CARD NO.x & HIT INPUT KEY message is displayed.

- Batch-saved data is stored on the memory cards under the following file names:
 - First memory card : FILE1.BAK
 - Second memory card : FILE2.BAK
 - Third memory card : FILE3.BAK
 - Fourth memory card : FILE4.BAK

Note that a file on a memory card can be overwritten. (If the specified name of a file to be saved duplicates that of a file already on the card, the old data will be overwritten.)
- For an explanation of the display during processing, see the description of the save/restore display.

- **Restoring data**

To execute the batch restoration of backup data, perform the following steps:

- (1) On the initial screen, select the LOAD FILE function.
- (2) The SET FILE1.BAK & HIT INPUT KEY message appears in the message field. Mount the first memory card containing FILE1.BAK, then press the  key. To cancel the processing, press the  key. The initial screen appears again.
 - * If FILE1.BAK cannot be found on the mounted memory card, or if any other error occurs, details are displayed in the message field. Follow the directions displayed in the message field. (When the HIT INPUT KEY message appears, the processing can be continued by pressing the  key.)
- (3) While data is being restored, the LOADING FROM IC-CARD message blinks. Once data restoration has been completed, the LOAD FILE COMPLETE and HIT INPUT KEY messages appear in the message field. When the  key is pressed, the initial screen appears again.

If all the required data cannot be restored from FILE1.BAK alone, the SET FILE2.BAK & HIT INPUT KEY message appears in the message field. Mount the second memory card containing FILE2.BAK without turning the power off, then press the  key.

To cancel the processing, press the  key. The initial screen appears again.

- (4) Backup data stored using up to four memory cards can be restored by performing step (3) repeatedly. If all the required data cannot be restored from all of the four memory cards, the FILE DATA SIZE ERROR and HIT INPUT KEY messages appear in the message field.

When the  key is pressed, the initial screen appears again.

NOTE

The function for saving or restoring a file in batch mode of the boot system assumes that the backup RAM (file SRAM) used for saving and that used for restoration are of the same size. So, this function should be used in the following cases:

- 1 To restore a file when file all clear must be executed (the file SRAM module is not replaced)
- 2 To restore a file when the file SRAM module must be replaced and when the size of the new backup RAM is the same

If this function is used for any other purpose, file restoration may not be performed correctly. Similarly, if an error (a RAM parity error, for example) is found in the contents of the backup RAM during batch saving, file restoration may not be performed correctly.

- **Save/restore display (screen display during batch saving/restoration of battery backup data) and notes**

When STORE FILE or LOAD FILE is selected, the size of the system battery backup file is displayed on the screen.

To save data, use memory cards conforming to the JEIDA V4.1 standard.

Prepare as many memory cards as necessary to give a total storage capacity that is greater than the displayed size. (The available storage capacity should be about 1.2 times greater than the displayed size.)

While data is being saved or restored, the size of data that has been saved or restored and the corresponding file name (on the memory card) are displayed.

```

FILE SIZE : 512K BYTE ← Size of system battery backup file
FILE1. BAK ← Name of file (on the memory card) that has been saved or restored
FILE2. BAK ← Name of file
              (on the memory card) which is being saved or restored

              00058000 ← Amount of data that has been saved
                          or restored (bytes)

*** MESSAGE ***
STORE TO IC-CARD
(LOADING FROM IC-CARD)

```

The file names are displayed in the following order: FILE1.BAK, FILE2.BAK, FILE3.BAK, FILE4.BAK.

The bottom line indicates either the name of the file currently being processed or which is about to be processed.

The displayed count changes up to the value indicated in the following table, according to the size of the system backup data file.

File size	Displayed count (hexadecimal)
64K BYTE	00010000
128K BYTE	00020000
256K BYTE	00040000
320K BYTE	00050000
512K BYTE	00080000
1M BYTE	00100000
2M BYTE	00200000

B.2.5 MEMORY CARD FORMAT Function

- **Description**

A memory card can be formatted. Formatting is necessary to prepare a blank memory card or a memory card whose contents have been destroyed due to failure of the battery or some other reason.

- **Screen configuration**

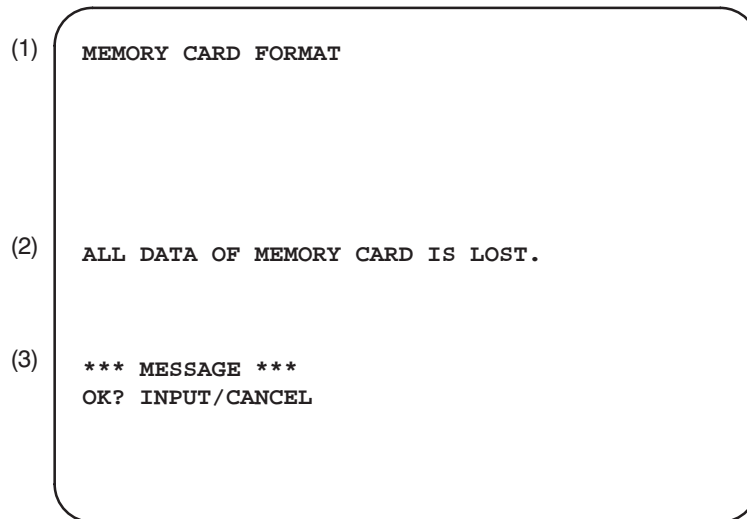

- (1) : Title
 (2) : Warning that all data will be lost as a result of formatting
 (3) : Message field
 (A quick operation guide may be displayed, for example.)

- **Operating procedure**

- (1) Mount a memory card in the memory card interface. The memory card must be unprotected.
- (2) Select 5 MEMORY CARD FORMAT from the SYSTEM MONITOR screen.
- (3) The OK INPUT/CANCEL message appears in the message field. To format the card, press the key. To cancel the processing, press the key.
- (4) When the key is pressed, a message is displayed to warn that all data on the memory card will be lost. Another OK INPUT/CANCEL message appears in the message field. To format the card, press the key. To cancel the processing, press the key.
- (5) While formatting is being performed, the EXECUTING message blinks in the message field.
- (6) Once formatting has been completed, the MEMORY CARD FORMAT HAS FINISHED HIT INPUT KEY message appears in the message field. Press the key. The main menu appears again.

B.2.6 LOAD BASIC SYSTEM

- **Description** The boot system terminates and the CNC starts.

- **Operating procedure** Select 6: END from the MAIN MENU screen. The boot system terminates and the CNC starts.
If the CNC basic software is not correctly stored in flash memory, the main menu appears again.

B.3 ERROR MESSAGES AND REQUIRED COUNTERMEASURES

The table below lists the error messages that may be output.

Error message	Description
IC CARD NOT READY	The IC memory card is not correctly mounted.
BATTERY ALARM (IC CARD)	A battery alarm occurred for the IC memory card.
ILLEGAL FORMAT FILE	The system cannot recognize the specified ROM file.
FLASH MEMORY NO SPACE	Flash memory has insufficient free space to store the specified ROM data.
IC-CARD MOUNT ERROR	An error occurred while the IC memory card was being mounted.
IC-CARD DISMOUNT ERROR	An error occurred while the IC memory card was being dismounted.
FILE OPEN ERROR	A file open error occurred.
FILE CLOSE ERROR	A file close error occurred.
FILE READ ERROR	A file read error occurred.
DIRECTORY SEARCH ERROR	No directory was found.
FILE SYSTEM xxxxxxxxxxxx	A file system error occurred.
DEVICE ERROR (CNC x) (PMC x)	A flash ROM memory device error occurred in the internal CNC or PMC device x.

If an error occurs, a corresponding error message is output, followed by the HIT INPUT KEY message. After checking the details, press the  key. The main menu appears again.

NOTE

If a flash ROM device error is detected, the HIT INPUT KEY message does not appear but the system stops. (The corresponding hardware must be replaced.)

- **SYSTEM ERROR screen**

```

(1) SYSTEM ERROR  xxxx y
(2) DRAM PARITY
(3) XXXXXXXX
(4)  xxxx  xxxx  xxxx  xxxx  xxxx  xxxx  xxxx  xxxx
    xxxx  xxxx  xxxx  xxxx  xxxx  xxxx  xxxx  xxxx
    xxxx  xxxx  xxxx  xxxx  xxxx  xxxx  xxxx  xxxx
    xxxx  xxxx  xxxx  xxxx  xxxx  xxxx  xxxx  xxxx

```

xxxx y : (xxxx) Boot ROM series
 (y) Boot ROM edition
 XXXXXXXX : Stack pointer
 XXXX : Contents of stack frame

- **Displayed items**

- (1) System error status, and series and edition of the boot ROM
 - (2) Type of system error
 - (3) Value of the stack pointer upon the occurrence of the system error
 - (4) Contents of the stack frame upon the occurrence of the system error.
Data of 40K bytes is displayed.
- * The meaning of the data depends on the type of the system error.
- * If a system error occurs, report the following to FANUC:
- (a) Contents of screen display
 - (b) LED status on the printed circuit board
 - (c) Operating procedure

B.4 SYSTEM ALARMS AND REQUIRED COUNTERMEASURES

System alarm (RAM parity error)

The first page of the system alarm screen is displayed as shown below.

(1) indicates the CPU of the board on which the RAM parity error is detected. (2) indicates the module, or similar, in which the RAM parity error was detected.

The indicated module, or similar, on the board may be defective. Replace the module.

<First page>

```

F15M14  A6D2A
RAM PARITY ERROR
( 1 ) ( 2 )
ERROR OCCURRED AT 1996-07-12  17:53:37
PROG COUNT : 00XXXXXX
CPU STATUS : XXXX
ACT TASK   : 00XX
ERROR ADRS : 00XXXXXX (00000000)

PAGE UP OR DOWN
```

(1) and (2) display one of the following messages:

(1)

- ¥1 CNC-MAIN : Main board
- ¥2 CNC-SUB : Sub-CPU board
- ¥3 CNC-AXIS : Axis CPU board
- ¥4 OTHER-CPU : Other printed circuit board

(2)

- ¥5 CNC-DRAM : DRAM module (See Sections 2.5.2 to 2.5.6.)
- ¥6 CNC-SRAM : SRAM module (See Sections 2.5.3 and 2.5.5.)
- ¥7 SHARED-RAM : SRAM module on the sub-CPU board
(See Section 2.5.13.)
- ¥8 FILE-RAM : FILE-SRAM module
(See Sections 2.5.2 to 2.5.6.)
- ¥9 MAXIS-BUS : Multiaxis bus
(This is not a module. The multiaxis main CPU
or multiaxis buffer board may be defective.)

System alarm (DRAM SUM error)

The first page of the system alarm screen is displayed as shown below.

(1) indicates the CPU of the board on which the DRAM SUM error is detected. The DRAM module on the indicated board may be defective. Replace the DRAM module.

<First page>

```
F15M14 A6D2A
DRAM SUM ERROR
( 1 )
ERROR OCCURRED AT 1996-07-12 17:53:37
PROG COUNT : 00XXXXXX
CPU STATUS : XXXX
ACT TASK   : 00XX
ERROR ADRS : 00XXXXXX (00000000)

PAGE UP OR DOWN
```

(1) displays one of the following messages:

(1)

¥1 CNC-MAIN : Main board (See Sections 2.5.2 to 2.5.6.)

¥2 CNC-SUB : Sub-CPU board (See Sections 2.5.15 to 2.5.17.)

¥3 CNC-AXIS : Axis CPU board (See Section 2.5.11.)

System alarm (bus error)

The first page of the system alarm screen is displayed as shown below.

A defective board can be identified from the ERROR ADRS value. This identification is possible only when the displayed ERROR ADRS value begins with 4.

<First page>

```

F15M14  A6D2A
BUS ERROR
CNC-XXXX FBUS-BUS
ERROR OCCURRED AT 1996-07-12  17:53:37
PROG COUNT : 00XXXXXX
CPU STATUS : XXXX
ACT TASK   : 00XX
ERROR ADRS : 4nXXXXXX (4nXXXXXX)

                *

                PAGE UP OR DOWN
```

The second digit, n, of 4nXXXXXX represents a possibly defective board, as follows (see Section 2.5).

¥1	n = 0:	Main board
¥2	n = 1:	PMC board
¥3	n = 3:	Sub-CPU board
¥4	n = 4:	Graphic board
¥5	n = 5:	Conversational board
¥6	n = 6:	Remote buffer
¥7	n = 8:	MMC board
¥8	n = C:	Tracing board

System alarm (line F emulator exception)

The first page of the system alarm screen is displayed as shown below.

(1) indicates the CPU of the board on which a line F emulator exception is detected. If the indicated board is CNC-MAIN or CNC-SUB, the software installation may be defective. Check the option configuration, installation, and so on.

<First page>

```
F15M14 A6D2A
L1111 EMUL.
( 1 )
ERROR OCCURRED AT 1996-07-12 17:53:37
PROG COUNT : 00XXXXXX
CPU STATUS : XXXX
ACT TASK   : 00XX
ERROR ADRS : 00XXXXXX (00000000)

PAGE UP OR DOWN
```

(1) displays one of the following messages:

(1)

¥1 CNC-MAIN : Main board

¥2 CNC-SUB : Sub-CPU board

¥3 CNC-AXIS : Axis CPU board

System alarm (servo alarm)

The first page of the system alarm screen is displayed as shown below.

The servo modules indicated as SERVO CPU #1/2/ /4/ may be defective.

In the example shown below, an error has occurred in the first, second, and fourth servo modules. Replace the corresponding servo modules.

<First page>

```

F15M14  A6D2A
SYSTEM ALARM
      SERVO CPU #1/2/ /4/  SERVO_ROM:9070A
ERROR OCCURRED AT 1995-07-12  21:14:50
PROG COUNT : XXXXXXXX
CPU STATUS : XXXX
ACT TASK   : XXXX
ERROR ADRS : XXXXXXXX (00000000)
CPU NO.   :  #1   #2   #3   #4   #5
ADSTS    :  XXXX  XXXX  XXXX  XXXX  XXXX
ALARMF   :  XXXX  XXXX  XXXX  XXXX  XXXX

```

PAGE UP OR DOWN

Servo modules are mounted on the following printed circuit boards:

- Main CPU board (See Sections 2.5.2 to 2.5.4.)
- Sub-CPU board (See Sections 2.5.15 and 2.5.17.)
- Additional axis board (See Section 2.5.18.)
- Axis CPU board (See Section 2.5.11.)

System alarm (file SRAM backup voltage drop)

The first page of the system alarm screen is displayed as shown below.

The following example indicates that the file SRAM backup battery on the main board is weak.

<First page>

```
F15M14 A6D2A
RAM PARITY ERROR (BATTERY LOW)
CNC-MAIN FILE-RAM
ERROR OCCURRED AT 1996-07-12 17:53:37
PROG COUNT : 00XXXXXX
CPU STATUS : XXXX
ACT TASK   : 00XX
ERROR ADRS : 8XXXXXXX (00000000)
BUS MASTER : CNC-MAIN
```

PAGE UP OR DOWN

- Replace the file SRAM backup battery.
- When the above continues to be displayed even after fitting a fresh file SRAM backup battery, the following may be defective:
 - File SRAM module (For an explanation of the mounting position, see Sections 2.5.2 to 2.5.6.)
 - Spindle module (For an explanation of the mounting position, see Sections 2.5.2 to 2.5.4.)
 - Main CPU PC board

(Important)

When the error indicated above is displayed, the data on part program storage has been lost. Before attempting to modify data (parameters, for example) on part program storage, make a backup copy on a floppy disk or other suitable media.

C ERROR CODE TABLE



C.1	ALARM LIST (CNC)	364
C.2	ALARM LIST (PMC)	383
C.3	PMC ERRORS	388

C.1 ALARM LIST (CNC)

Number	Message displayed on CRT	Contents	Remarks
PS 003	TOO MANY DIGITS	Data entered with more digits than permitted. (See APPENDIX 2, "Table of Maximum Command Values.")	
PS 006	ILLEGAL USE OF NEGATIVE VALUE	A minus sign (-) was specified at an address where no minus sign may be specified, or two minus signs were specified.	
PS 007	ILLEGAL USE OF DECIMAL POINT	A decimal point (.) was specified at an address where no decimal point may be specified, or two decimal points were specified.	
PS 010	IMPROPER G-CODE	An illegal G code was specified. This alarm is also generated when a G code for an option that has not been added is specified.	
PS 011	IMPROPER NC-ADDRESS	An illegal address was specified. A command was specified for a slave axis during synchronous operation or independent operation of a slave axis.	
PS 012	INVALID BREAK POINT OF WORD	NC word(s) are delimited incorrectly.	
PS 013	ILLEGAL PROGRAM NO. POSITION	Address O or N is specified in an illegal location (i.e. after a macro statement, etc.)	
PS 014	ILLEGAL PROGRAM NO. FORMAT	Address O or N is not followed by a number.	
PS 015	TOO MANY WORDS IN ONE BLOCK	The number of words in a block exceeds the maximum.	
PS 016	EOB NOT FOUND	EOB (End of Block) code is missing at the end of a program input in MDI mode.	
PS 017	ILLEGAL MODE FOR GOTO/WHILE/DO	A GOTO statement or WHILE-DO statement was found in the main program in MDI or tape mode.	
PS 058	S-COMMAND OUT OF RANGE	The specified spindle speed exceeded the maximum number of revolutions allowed for the spindle motor (parameter No. 5619). (When SAL of parameter No. 5601 is 1)	
PS 059	COMMAND IN BUFFERING MODE	Manual intervention compensation request signal MIGET was input for a block containing no M code without buffering.	

T: Only for the Series 15-T and 15-TT used with lathes

NOTE

PSxxx indicates alarms related to programs or settings in the foreground. Background alarms corresponding to PSxxx are displayed in the format BGxxx.
Similarly, background alarms corresponding to RSxxx are also displayed in the format BGxxx.

Number	Message displayed on CRT	Contents	Remarks
PS 060	SEQUENCE NUMBER NOT FOUND	The specified sequence No. was not found during sequence number search. The sequence No. specified as the jump destination in GOTO _n or M99P _n was not found.	
PS 061	NO P, Q COMMAND AT G70–G72	Neither P nor Q was specified in a block of multiple repetitive canned cycles G70 to G73 for turning. (P: Sequence No. of the start cycle block Q: Sequence No. of the end cycle block)	T
PS 062	ILL COMMAND IN G70–G76	<ul style="list-style-type: none"> · The value specified by address D in a G71, G72, or G73 block is zero or negative. · The value specified by address K or D in a G76 block is zero or negative, or the value specified by address A is out of bounds (valid range: $0^\circ \leq A^\circ \leq 120^\circ$). · The value specified by I, K, or D in a G74 or G75 block is negative. · X is specified even though the value specified by I in a G74 or G75 block is zero, or Z is specified even though the value specified by K is zero. 	T
PS 063	P, Q BLOCK NOT FOUND	The blocks indicated by the sequence Nos. specified in P or Q in a block of multiple repetitive canned cycles G70 to G73 for turning were not found.	T
PS 064	SHAPE PROGRAM NOT MONOTONOUS	The change in movement along the Z-axis in the G71 finishing program, or that along the X-axis in the G72 finishing program, is not monotonous.	T
PS 065	ILL COMMAND IN P-BLOCK	Group 01 G code G00 or G01 has not been specified in the blocks indicated by P or Q in the blocks of multiple repetitive canned cycles G70 to G72 for turning.	
PS 066	ILL COMMAND IN PROGRAM	A group 01 G code other than G00, G01, G02, or G03, a single-shot G codes other than G04, or G65, G66, G67, M98, or M99 was specified in one of the blocks specified by the sequence numbers specified in P and Q of canned cycle G70, G71, or G72.	T
PS 067	G70–G73 IN FORBIDDEN MODE	Multiple respective canned cycle G70, G71, G72, or G73 is specified in a mode other than memory mode.	T
PS 069	ILL COMMAND IN Q-BLOCK	Chamfering or cornering is specified in a block indicated by the sequence No. specified in Q in a block of multiple repetitive canned cycles G70 to G73 for turning.	T
PS 076	PROGRAM NOT FOUND	The program indicated by the program No. called by M98, G65, G66, G66.1, or a G, M, or T code could not be found.	
PS 077	PROGRAM IN USE	An attempt was made in the foreground to execute a program being edited in the background.	
PS 079	PROGRAM FILE NO NOT FOUND	The specified program could not be found. This alarm occurs when a program specified by M198 is not registered in external memory. This alarm also occurs when a remote buffer is being used and an attempt is made to execute a program by specifying its program No. M198.	
PS 090	DUPLICATE NC, MACRO STATEMENT	An NC statement and macro statement were specified in the same block.	
PS 091	DUPLICATE SUB-CALL WORD	More than one subprogram call instruction was specified in the same block.	
PS 092	DUPLICATE MACRO-CALL WORD	More than one macro call instruction was specified in the same block.	
PS 093	DUPLICATE NC-WORD &M99	An address other than O, N, P, or L was specified in the same block as M99 during the macro continuous-state call state (G76).	

Number	Message displayed on CRT	Contents	Remarks
PS 094	G CANNOT BE ARGUMENT	Address G was used as the argument of a macro.	
PS 095	TOO MANY TYPE-2 ARGUMENTS	More than 10 sets of type-II arguments were specified for custom macros.	
PS 100	CANCEL WITHOUT MODAL CALL	Call mode cancel (G67) was specified even though macro continuous-state call mode (G66) was not in effect.	
PS 110	OVERFLOW: INTEGER	An integer went out of range during arithmetic calculations (valid range: -2^{31} to $2^{31}-1$)	
PS 111	OVERFLOW: FLOATING	A binary floating point number went out of range during arithmetic calculations.	
PS 112	DIVISION BY ZERO	An attempt was made to divide by zero in a custom macro.	
PS 114	VARIABLE NO. OUT OF RANGE	An illegal variable No. was specified in a custom macro.	
PS 115	READ PROTECTED VARIABLE	An attempt was made in a custom macro to use on the right side of an expression a variable that can only be used on the left side of an expression.	
PS 116	WRITE PROTECTED VARIABLE	An attempt was made in a custom macro to use on the left side of an expression a variable that can only be used on the right side of an expression.	
PS 118	TOO MANY NESTED BRACKETS	Too many brackets ([]) were nested in a custom macro.	
PS 119	ARGUMENT VALUE OUT OF RANGE	An argument of a function in a custom macro is out of range.	
PS 121	TOO MANY SUB, MACRO NESTING	1) The total number of subprogram and macro calls exceeds the allowable range. 2) An M98 or M198 command was called by external memory or a subprogram. The program specified by M198 contains an M98 or M198 command.	
PS 122	TOO MANY MACRO NESTING	Too many macros calls were nested in a custom macro.	
PS 123	MISSING END STATEMENT	The END command corresponding to a prior DO command was missing in a custom macro.	
PS 124	MISSING DO STATEMENT	The DO command corresponding to a post END command was missing in a custom macro.	
PS 125	ILLEGAL EXPRESSION FORMAT	There is an error in the format used in an expression.	
PS 126	ILLEGAL LOOP NO.	DO and END Nos. exceed the allowable range.	
PS 128	SEQUENCE NO. OUT OF RANGE	A sequence Nos. was out of range (valid range: 1 to 9999).	
PS 131	MISSING OPEN BRACKET	The number of left brackets ([) is less than the number of right brackets (]) in a custom macro.	
PS 132	MISSING CLOSE BRACKET	The number of right brackets (]) is less than the number of left brackets ([) in a custom macro.	
PS 133	MISSING "="	An equals sign (=) is missing in a custom macro.	
PS 134	MISSING "/"	A division sign (/) is missing in a custom macro.	
PS 135	MACRO STATEMENT FORMAT ERROR	There is an error in the format used in a macro statement in a custom macro.	
PS 136	DFA STATEMENT FORMAT ERROR	There is an error in the format used in a DFA statement in a custom macro.	
PS 137	IF STATEMENT FORMAT ERROR	There is an error in the format used in an IF statement in a custom macro.	

Number	Message displayed on CRT	Contents	Remarks
PS 138	WHILE STATEMENT FORMAT ERROR	There is an error in the format used in a WHILE statement in a custom macro.	
PS 139	SETVN STATEMENT FORMAT ERROR	There is an error in the format used in a SETVN statement in a custom macro.	
PS 141	ILLEGAL CHARACTER IN VAR. NAME	A SETVN statement in a custom macro contains a character that cannot be used in a variable name.	
PS 142	VARIABLE NAME TOO LONG	The variable name used in a SETVN statement in a custom macro is too long.	
PS 143	BPRNT/DPRNT STATE- MENT FORMAT ERROR	There is an error in the format used in a BPRNT or DPRNT statement specified for external output from a custom macro.	
PS 144	G10 FORMAT ERROR	There is an error in the G10 format.	
PS 145	G10.1 TIME OUT	The response to a G10.1 command was not received from the PMC within the specified time limit.	
PS 146	G10.1 FORMAT ERROR	There is an error in the G10.1 format.	
PS 150	G31 FORMAT ERROR	The G31.8 command contains one of the following errors : – No axis is specified. – More than one axis is specified. – P is omitted.	
PS 180	ALL PARALLEL AXES IN PARKING	All of the parallel axes for an address are parked (the parking signal is on).	
PS 181	ZERO RETURN NOT FINISHED	During automatic operation, a movement command was issued for an axis for which reference position has not been performed since power-on.	
PS 182	CIRCLE CUT IN RAPID TRAVERSE	F0 (rapid traverse in inverse feed or feed specified by an F code with one-digit number was specified during circular interpolation (G02, G03) or involute interpolation (G02.2, G03.2) mode.	
PS 183	TOO MANY SIMULTA- NEOUS CONTROL AXES	A move command was specified for more axes than can be controlled by simultaneous axis control.	
PS 184	TOO LARGE DISTANCE	Due to compensation or similar reasons, a movement distance was specified that exceeds the maximum allowable distance.	
PS 185	ZERO RETURN CHECK(G27) ERROR	The axis specified in G27 (reference position return check) has not returned to the reference position.	
PS 186	ILLEGAL PLANE SELECTION	There is an error in the plane selection command (parallel axes are being specified at the same time).	
PS 187	FEEDRATE IS 0 (F COMMAND)	The cutting feedrate has been set to 0 by an F code.	
PS 188	DRY RUN FEEDRATE IS 0	The maximum feedrate or the dry run feedrate has been set to 0 by parameter.	
PS 190	CUTTING FEEDRATE IS 0	The maximum cutting feedrate has been set to 0 by parameter.	
PS 191	RADIUS TOO LARGE	An arc was specified for which the difference in the radius at the start and end points exceeds the value set in parameter 2410.	
PS 192	ILLEGAL LEAD COMMAND (G34)	In variable lead threading, the lead compensation value set with address K is greater than the maximum allowed value (the lead is negative or greater than the maximum allowed size).	
PS 193	ILLEGAL OFFSET NUMBER	An incorrect offset No. was specified.	
PS 194	ZERO RETURN END NOT ON REF	The axis specified in G28 (automatic reference position return) was not at the reference position when positioning was completed.	
PS 195	ILLEGAL AXIS SELECTED (G96)	An incorrect value was specified in P in a G96 block or parameter 5640.	
PS 196	ILLEGAL DRILLING AXIS SELECT	An illegal axis was specified for drilling in a canned cycle for drilling.	

Number	Message displayed on CRT	Contents	Remarks
PS 197	OTHER AXIS ARE COMMANDED	A command was issued for another axis at the same time a command was being issued for the index table axis.	
PS 198	ILLEGAL INDEX ANGLE	A value other than an integer multiple of the degree increment used by the index table was specified.	
PS 199	ILLEGAL COMMAND IN INDEXING	An illegal command was specified for indexing using the index table.	
PS 200	PULSE CODER INVALID ZERO RETURN	The grid position could not be set during grid reference position return using a digital position detector, because the one-revolution signal was not received before leaving the deceleration dog.	
PS 201	ILLEGAL LEAD COMMAND (G35) G02.1/03.1	During circular threading, a command for changing the long axis was issued.	
PS 201	G02.1/03.1 FORMAT ERROR	The specified arc exceeds the range where interpolation can be performed.	
PS 205	TURRET REF. NOT FINISHED	Indexing was specified without first performing reference position return of the turret axis.	
PS 206	ILLEGAL TOOL NO.	An invalid tool No. was specified.	
PS 210	ILLEGAL WAITING M-CODE	An M command with three-digit number is issued to a tool post which then entered a waiting state while a different M command with three-digit number was issued for another tool post.	TT
PS 211	PROGRAM NUMBER ODD/ EVEN ERROR	An attempt was made to execute an even-numbered program on the first tool post or an odd-numbered program on the second tool post.	TT
PS 212	ILLEGAL BALANCE CUT- TING G-CODE	A G68 command was issued to a tool post which then entered a waiting state while a G69 command was issued for another tool post, or a G69 command was issued to a tool post which then entered a waiting state while a G68 command was issued for another tool post.	TT
PS 213	ILLEGAL USE OF PS213 G12.1/G13.1	Conditions are not correct for starting or cancelling polar coordinate interpolation. <ul style="list-style-type: none"> · G12.1 or G13.1 was commanded in a mode other than G40. · An illegal plane was selected (error in parameter 1032 or 1033). 	
PS 214	ILLEGAL USE OF G-CODE	A G code which cannot be specified in G12.1 mode was specified.	
PS 215	TOOL RETRACTION INCORRECT	The retract command was specified incorrectly (long axis was specified in threading).	
PS 217	ILLEGAL OFFSET VALUE	Illegal offset number	
PS 218	FORMAT ERROR	Illegal format	
PS 223	ILLEGAL SPINDOLE SELECT	Although spindle control is disabled (G10.7 P0), an S code is specified.	
PS 229	G10.7 FORMAT ERROR	Address P specified in the G10.7 block is not 0, 1, or 2.	
PS 270	OFFSET START/STOP IN C MODE	An attempt was made to start or cancel tool tip radius compensation during arc mode.	
PS 271	CRC: ILLEGAL PLANE	An attempt was made to change the plane while offset C was in effect.	
PS 272	CRC: INTERFERENCE	The depth of cut is too great while offset C is in effect.	
PS 280	ILLEGAL COMMAND IN SPI- RAL	An illegal command was specified for spiral or conical interpolation. (R was specified.)	
PS 281	OVER TOLERANCE OF END POINT IN SPIRAL	The difference between the positions of the specified and calculated end points exceeds the permissible value.	
PS 299	CRC: NO INTERSECTION	There is no point of intersection in offset C.	

Number	Message displayed on CRT	Contents	Remarks
PS 300	ILLEGAL ADDRESS	An illegal address was specified while loading parameters or pitch error compensation data from a tape.	
PS 301	MISSING ADDRESS	An address was found to be missing while loading parameters or pitch error compensation data from a tape.	
PS 302	ILLEGAL DATA NUMBER	An invalid data No. was found while loading parameters or pitch error compensation data from a tape.	
PS 303	ILLEGAL AXIS NUMBER	An invalid axis No. was found while loading parameters from a tape.	
PS 304	TOO MANY DIGITS	Data with too many digits was found while loading parameters or pitch error compensation data from a tape.	
PS 305	DATA OUT OF RANGE	Out-of-range data was found while loading parameters or pitch error compensation data from a tape.	
PS 306	MISSING AXIS NUMBER	A parameter which requires an axis to be specified was found without an axis No. while loading parameters from a tape.	
PS 307	ILLEGAL USE OF MINUS SIGN	Data with an illegal sign was found while loading parameters or pitch error compensation data from a tape.	
PS 308	MISSING DATA	An address not followed by a numeric value was found while loading parameters or pitch error compensation data from a tape.	
PS 400	PROGRAM DOES NOT MATCH	The program in memory does not match the program stored on tape.	
PS 410	G37 INCORRECT	No axis or more than one axis was specified in a tool measurement command block.	
PS 411	G37 SPECIFIED WITH D/H CODE	A D or H code was specified in the same block as an automatic tool-length measurement command.	
PS 412	G37 OFFSET NO. UNASSIGNED	No D or H code was specified before the tool length measurement command.	
PS 413	G37 SPECIFIED WITH T-CODE	A T code was specified in the same block as a tool length measurement command.	
PS 414	G37 OFFSET NO. UNASSIGNED	No T code was specified before the tool length measurement command.	
PS 415	G37 ARRIVAL SGNL NOT ASSERTED	During tool measurement, the measurement position arrival signal went on before the machine was in the area specified by parameter ϵ , or the measurement position arrival signal did not go on at all.	
PS 418	SPINDLE & OTHER AXIS MOVE	Spindle and other axis are specified in the same block for spindle positioning.	
PS 419	SPINDLE NOT ZERO RETURNED	Orientation (zero position return) was not completed in spindle positioning.	
PS 421	SETTING COMMAND ERROR	Command for setting tool data (G10L70 to G11, G10L71 to G11) is specified incorrectly. (Tool number specified for tool offset.)	
PS 422	TOOL DATA NOT FOUND	The pot number, tool length compensation data, and cutter compensation data has not been set for the specified tool number (tool number specified for tool offset).	
PS 425	TOOL DATA CANNOT BE DELETED	Tool data specified by the tool selection command cannot be deleted.	
PS 426	TOO MANY ADDRESSES	More than one of I, (J), K, or R was specified in the same block as chamfering or cornering. Example) G01X—K—R ;	
PS 427	TOO MANY AXES FOR I-R MOVE	There is no single-axis movement command specified in a block in which chamfering or corner rounding is specified. Example) G01X—Z—K— ;	
PS 428	MISMATCH AXIS WITH CNR, CHF	I was specified with axis X or K was specified with axis Z in a block in which chamfering or corner rounding is specified. Example) G01X—I— ; G01Z—K— ;	

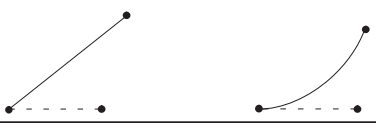
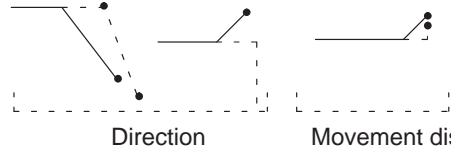
Number	Message displayed on CRT	Contents	Remarks
PS 429	MISSING VALUE AT CNR, CHF	The specified movement distance is less than the specified cornering or chamfering amount in a block in which chamfering or cornering is specified. 	
	MISSING VALUE AT CNR, CHF	When a block with cornering or chamfering was inserted, the original movement command range was exceeded.	M
PS 430	CODE ISN'T G01 AFTER CNR, CHF	The command following a block in which cornering or chamfering was specified is not G01. Example) N1 G01X—K— ; N2 G00Z—I— ;	
PS 431	MISSING MOVE AFTER CNR, CHF	The direction or movement distance specified in the block following a block in which cornering or chamfering is specified is incorrect. 	T
PS 431	MISSING MOVE AFTER CNR, CHF	The block following a block in which cornering or chamfering is specified is not a linear or circular interpolation block.	M
PS 437	ILLEGAL LIFE GROUP NUMBER	A tool group number exceeded the maximum value.	
PS 438	TOOL GROUP NOT SET	A tool group which has not been set was specified in a machining program.	
PS 439	TOO MANY TOOLS	The number of tools specified in a single tool group exceeded the maximum allowed number.	
PS 440	T COMMAND NOT FOUND (G10L3)	No T command was specified in a program which sets a tool group.	
PS 441	NOT USING TOOL IN LIFE GROUP	An H99 or D command was specified when no tool that belongs to a group was being used.	
PS 442	ILLEGAL T COMMAND AT M06	The tool group of the tool specified in the tool command (return tool group) after the M06 command in a machining program does not match the current tool group.	
PS 443	NOT FOUND P, L COMMAND	No P or L command was specified at the beginning of a program that sets a tool group.	
PS 445	ILLEGAL L COMMAND	The value specified in an L command in a program that sets a tool group is 0 or a value greater than the maximum tool life.	
PS 446	ILLEGAL T COMMAND	The value specified in a T command in a program that sets a tool group is greater than the maximum allowed value.	T
PS 446	ILLEGAL H D T COMMAND	The value specified by an H, D, or T command in a program that sets a tool group is greater than the maximum allowed value.	M
PS 447	ILLEGAL TYPE OF TOOL CHANGE	The tool change method is set incorrectly.	M
PS 448	UNUSABLE ADDRESS (G10L3)	A command that cannot be specified in a program that sets a tool group was specified.	
PS 449	NO TOOL LIFE DATA	A tool group was specified in a machining program even though no tool groups have been set.	
PS 450	IN PMC AXIS MODE	In the PMC axis control mode, the CNC issued a move command for the PMC axis. This alarm can be suppressed by setting NPAA of parameter No. 2405 to 1.	
PS 533	S CODE ZERO	The S code for rigid tapping is not specified.	

Number	Message displayed on CRT	Contents	Remarks
PS 573	EGB PARAMETER SETTING ERROR	EGB parameter setting error. (1) SYNAXS, bit 0 of parameter 1955, was erroneously set. (2) The rotation axis was not specified (bits 0 and 1 of parameter No. 1006). The synchronous start command with the number of turns was specified for the slave axis. (3) The number of pulses distributed per turn was not specified (parameter Nos. 5996 and 5997).	
PS 574	EGB FORMAT ERRO	Format error in the block in which the EGB command was specified (1) No command was specified for the master or slave axis. (2) Data which is out of range was specified for the master or slave axis. (3) A travel distance was specified for the master axis although the axis was not an NC-controlled axis (parameter No. 5998 was set to 0).	
PS 575	ILL-COMMAND IN EGB MODE	One of the illegal commands shown below was specified during EGB synchronization. (1) One of commands specified for the slave axis, such as G27, G28, G29, G30, and G53 (2) One of inch/millimeter conversion commands, such as G20 and G21	
PS 577	G80 FORMAT ERROR	Format error in that block in which the G80 code was specified (1) R falls outside the valid range.	
PS 578	G80 PARAMETER SETTING ERROR	Erroneous G80 parameter setting (1) The acceleration/deceleration parameter is invalid.	
PS 580	ENCODE ALARM (PSWD & KEY)	When an attempt was made to read a program, the specified password did not match the password on the tape and password on tape was not equal to 0. When an attempt was made to punch an encrypted tape, the password did not range from one to 99999999 inclusive.	
PS 581	ENCODE ALARM (PARAMETER)	When an attempt was made to punch an encrypted tape, the punch code parameter was set to EIA. An incorrect command was specified for program encryption or protection.	
PS 585	G81 PARAMETER SETTING ERROR	Erroneous G81-parameter setting 1 (1) SYNAXS, bit 0 of parameter 1955, was erroneously set. (2) The slave axis was not specified as a rotation axis (bits 0 and 1 of parameter No. 1006). (3) Parameter No. 5995 was not set. (4) The acceleration/deceleration parameter is invalid. (5) The automatic phase synchronization parameter is invalid.	
PS 586	G81 FORMAT ERROR	Format error in the block in which the G81 code was specified (1) T (number of teeth) was not specified. (2) Data which was out of range was specified for T or L. (3) An overflow occurred in the calculation of synchronous coefficients. (4) R falls outside the valid range. (5) The synchronous feedrate for the workpiece axis is greater than or equal to the rapid traverse rate (parameter No. 1420).	

Number	Message displayed on CRT	Contents	Remarks
PS 587	ILL-COMMAND IN G81 MODE	One of the illegal commands shown below was specified during G81 synchronization. (1) One of commands specified for the C-axis, such as G27, G28, G29, G30, and G53 (2) One of inch/millimeter conversion commands, such as G20 and G21	
PS 610	ILLEGAL G07.1 AXIS	Axis which cannot perform cylindrical interpolation was specified. More than one axis was specified in a G07.1 block. An attempt was made to cancel cylindrical interpolation for an axis that was not in cylindrical interpolation mode.	
PS 611	ILLEGAL G-CODE USE (G07.1 MODE)	A G code was specified that cannot be specified in cylindrical interpolation mode.	
PS 625	TOO MANY G68 NESTING	3-dimensional coordinate switching (G68) was specified more than twice.	
PS 626	G68 FORMAT ERROR	There is a format error in a G68 block. This alarm occurs in the below cases: (1) When I, J, or K is missing from the block in which G68 is specified (when the coordinate rotation option is not available) (2) When I, J, and K specified in the block in which G68 is specified are all 0 (3) When R is not specified in the block in which G68 is specified Note) For the 15-T/TT, read G68 as G68.1.	
PS 630	HPCC:ILLEGAL START U/ CANCEL	G05P10000 was specified in a mode which cannot enter the HPCC mode (See Section 2.1.1) The HPCC mode was canceled without canceling the cutter compensation mode (G41/ G42).(G40 is required before G50P0.)	
PS 631	HPCC:NOT READY STATE	The RISC processor board is not ready for operation.	
PS 632	HPCC:ILLEGAL PARAMETER	The setting of a parameter is invalid.	
PS 633	HPCC:CRC OFS REMAIN AT CANCEL	The HPCC mode was canceled with a cutter compensation value retained.	
PS 634	HPCC:ILLEGAL COMMAND CODE	An invalid code was specified in the HPCC mode. (Refer to 2.1.2). In a block that includes positioning, or auxiliary function, cutter compensation (G41, G42), cancel (G40), vector retention (G38), corner arc (G39), or macro call was specified.	
PS 710	ILLEGAL COMMAND IN SPACE-CIR	An error was found in the specification for three dimensional circular interpolation.	
PS 711	ILLEGAL COMBINATION OF M CODES	M codes of the same group are specified in the same block. Or, an M code which must be specified alone is specified with an other M code in a block.	
PS 805	ILLEGAL COMMAND	A command is specified incorrectly in a block.	
PS 891	ILLEGAL COMMAND G05	G05 was specified in a state in which G05 cannot be specified.	M
PS 895	ILLEGAL PARAMETER IN G02.3/G03.3	The setting (parameter No. 7636) that specifies the axis for which to perform exponential interpolation is incorrect.	M
PS 896	ILLEGAL FORMAT IN G02.3/G03.3	The format for specifying exponential interpolation is incorrect (addresses I, J, or R are not specified, are set to 0, or the span value is negative).	M
PS 897	ILLEGAL COMMAND IN G02.3/G03.3	An illegal value was specified in exponential interpolation (i.e. parameter 1n is negative, etc.)	
PS 898	ILLEGAL PARAMETER IN G54.2	An illegal parameter (6068 to 6076) was specified for fixture offset.	
PS 900	G72.1 NESTING ERROR	G72.1 was specified again during G72.1 rotation copying.	

Number	Message displayed on CRT	Contents	Remarks
PS 901	G72.2 NESTING ERROR	G72.2 was specified again during G72.2 parallel copying.	
PS 920	ILL-COMMAND IN G05.1 Q1	An invalid command was specified in G05.1 Q1 (look-ahead acceleration/deceleration before interpolation) mode. (1) F1-digit command	
PS 935	ILLEGAL FORMAT IN G02.2/G03.2	The end point of an involute curve, or I, J, K, or R was not specified.	
PS 936	ILLEGAL COMMAND IN G02.2/G03.2	An illegal value was specified in involute interpolation. (1) The start point or end point is specified inside the basic circle. (2) I, J, K, or R was specified as 0.	
PS 937	OVER TOLERANCE OF END POINT	The end point is not positioned on the involute curve that passes through the start point (the value specified in parameter No. 2510 is out of range).	
PS 990	SPL : ERROR	The spline interpolation axis command is invalid. In NURBS interpolation by high-precision contour control using a RISC processor: (1) An invalid rank was specified. (2) No knot, or an invalid knot, was specified. (3) Too many axes were specified. (4) Another program error was detected.	
PS 991	SPL : ERROR	A G06.1 command was specified in a G code mode in which the command is not supported.	
PS 992	SPL : ERROR	Movement was specified for an axis other than those used for spline interpolation. In NURBS interpolation by high-precision contour control using a RISC processor: (1) A program error was detected in the block to be read in advance. (2) Increase in knots is not monotonous. (3) A mode which cannot be used in NURBS interpolation mode was specified.	
PS 993	SPL : ERROR	A three-dimensional tool offset vector cannot be generated. In NURBS interpolation by high-precision contour control using a RISC processor, the first control point for NURBS is invalid.	
PS 994	SPL : ERROR	In NURBS interpolation by high-precision contour control using a RISC processor, NURBS interpolation was resumed after manual intervention with the manual absolute switch set to ON.	
PS 996	G41.3/G40 FORMAT ERROR	A move command was specified in the block in which the G41.3 or G40 code was specified. A G or M code which suppresses buffering was specified in the block in which the G41.3 code was specified.	
PS 997	ILLEGAL COMMAND IN G41.3	A G code other than G00 or G01 in group 01 was specified in the continuous state of the G41.3 code. An offset command (G code in group 07) was specified in the G41.3 mode. The block following the block in which G41.3 (start up) was specified did not have a move command.	
PS 998	G41.3 ILLEGAL START UP	The G41.3 code (start up) was specified in the continuous state of a G code other than G00 or G01 in group 01. The angle formed by the tool-direction vector and the movement-direction vector was 0 or 180 degrees at start up.	
PS 999	ILLEGAL PARAMETER IN G41.3	A parameter which determines the relationship between the rotation axis and rotation plane was erroneously set (parameter Nos. 1022 and 6080 to 6089)	

Number	Message displayed on CRT	Contents	Remarks
SR 160	INTERNAL DATA OVER FLOW	Coordinates specified in an absolute or machine coordinate system are out of range. In general, this alarm is generated when the rotational axis is rotated a number of times and an absolute coordinate becomes greater than +99999.999 or less than -99999.999 (for increment system IS-B). Perform reference position return when this alarm occurs.	
SR 310	H, S, C ERROR	G10.3, G11.3, or G65.3 is used incorrectly.	
SR 311	H, S, C ERROR	A command not permitted during high-speed machining was specified.	
SR 312	H, S, C ERROR	Address P, Q, or L is out of range.	
SR 313	H, S, C ERROR	High-speed machining data does not exist for the number that was called.	
SR 314	H, S, C ERROR	No cluster exists for the number that was called.	
SR 315	H, S, C ERROR	An attempt was made to register a number for which high-speed machining data already exists.	
SR 316	H, S, C ERROR	Memory is full.	
SR 317	H, S, C ERROR	The maximum number of sets of high-speed machining data has been registered (no additional high-speed machining data can be registered).	
SR 318	H, S, C ERROR	An attempt was made to register high-speed machining data during background editing.	
SR 319	H, S, C ERROR	There is an error in the format of high-speed machining data.	
SR 320	H, S, C ERROR	A macro interrupt occurred during high-speed machining.	
SR 424	OVER MAXIMUM TOOL DATA	An attempt was made to register new tool data even though the maximum number of sets of tool data has already been set (tool No. specified for tool offset).	
SR 590	TH ERROR	TH alarm (A character with a parity error was entered in a significant data area.)	
SR 591	TV ERROR	TV alarm (The number of characters in a block was not even.)	
SR 592	END OF RECORD	EOR (End of Record) was specified partway through a block.	
SR 600	PARAMETER OF RESTART ERROR	There is an error in the specification of the program restart parameter.	
SR 805	ILLEGAL COMMAND	An attempt was made to use an illegal command for the reader/punch interface. This is generally a system error.	
SR 806	DEVICE TYPE MISS MATCH	An attempt was made to use a command which is invalid for the currently selected I/O device. For example, this alarm occurs when an attempt is made to perform a file head search even though the medium is not a FANUC floppy disk.	
SR 807	PARAMETER SETTING ERROR	An I/O interface which was not selected as an option was specified, or the settings or parameters related to the I/O interface are set incorrectly.	
SR 810	PTR NOT READY	The ready signal for the tape reader is off.	
SR 812	OVERRUN ERROR (PTR)	The next character was received by the tape reader before it could read a previously received character.	
SR 820	DR OFF(1)	The data set ready signal for reader/punch interface 1 went off.	
SR 821	CD OFF(1)	The signal quality detection signal for reader/punch interface 1 went off.	
SR 822	OVERRUN ERROR(1)	The next character was received by reader/punch interface 1 before it could read a previously received character.	
SR 823	FRAMING ERROR(1)	No stop bit was detected for a character received by reader/punch interface 1.	

Number	Message displayed on CRT	Contents	Remarks
SR 824	BUFFER OVERFLOW(1)	The NC received more than ten characters of data from reader/punch interface 1 even though the NC sent a stop code (DC3) during data reception.	
SR 830	DR OFF(2)	The data set ready signal for reader/punch interface 2 went off.	
SR 831	CD OFF(2)	The signal quality detection signal for reader/punch interface 2 went off.	
SR 832	OVERRUN ERROR(2)	The next character was received by reader/punch interface 2 before it could read a previously received character.	
SR 833	FRAMING ERROR(2)	No stop bit was detected for a character received by reader/punch interface 2.	
SR 834	BUFFER OVERFLOW(2)	The NC received more than ten characters of data from reader/punch interface 2 even though the NC sent a stop code (DC3) during data reception.	
SR 840	DR OFF(3)	The data set ready signal for reader/punch interface 2 went off.	
SR 841	CD OFF(3)	The signal quality detection signal for reader/punch interface 3 went off.	
SR 842	OVERRUN ERROR(3)	The next character was received by reader/punch interface 3 before it could read a previously received character	
SR 843	FRAMING ERROR(3)	No stop bit was detected for a character received by reader/punch interface 3.	
SR 844	BUFFER OVERFLOW(3)	The NC received more than ten characters of data from reader/punch interface 3 even though the NC sent a stop code (DC3) during data reception.	
SR 860	DATA SET READY DOWN (ASR33/43)	The data set ready signal for the 20 mA current loop interface went off.	
SR 861	CARRIER DETECT DOWN (ASR33/43)	The signal quality detection signal for the 20 mA current loop interface went off.	
SR 862	OVERRUN ERROR (ASR33/43)	The next character was received by the 20 mA current loop interface before it could read a previously received character.	
SR 863	FRAMING ERROR (ASR33/ASR44)	No stop bit was detected for a character received by the 20 mA current loop interface.	
SR 864	BUFFER OVERFLOW (ASR33/ASR44)	The NC received more than ten characters of data from the 20 mA current loop interface even though the NC sent a stop code (DC3) during data reception.	
SR 870	DATA SET READY DOWN (RS422)	The data mode signal for the RS-422 interface went off.	
SR 872	OVERRUN ERROR (RS422)	The next character was received by the RS-422 interface before it could read a previously received character.	
SR873	FRAMING ERROR (RS422)	No stop bit was detected for a character received by the RS-422 interface.	
SR 874	BUFFER OVERFLOW (RS422)	The NC received more than ten characters of data from the RS-422 interface even though the NC sent a stop code (DC3) during data reception.	
SR 880	NOT DRAWING	Communication cannot be made with the graphic CPU.	
SR 890	CHECK SUM ERROR (G05)	A check sum error occurred (high-speed remote buffer).	

Number	Message displayed on CRT	Contents	Remarks
OH 000	MOTOR OVERHEAT	A servo motor overheated.	Axis type
OH 001	LOCKER OVERHEAT	The NC cabinet overheated.	

Axis type : Error codes of this type are specified for each axis for which it occurs.

Number	Message displayed on CRT	Contents	Remarks
SB 010	GRAPHIC RAM PARITY	A parity error occurred in the graphic ROM.	
SB 011	GRAPHIC RAM PARITY (WORK)	A parity error occurred in the graphic work RAM.	
SB 011	GRAPHIC RAM PARITY (RED)	A parity error occurred in the RAM for red graphics.	
SB 011	GRAPHIC RAM PARITY (GREEN)	A parity error occurred in the RAM for green graphics.	
SB 011	GRAPHIC RAM PARITY (BLUE)	A parity error occurred in the RAM for blue graphics.	

Number	Message displayed on CRT	Contents	Remarks
SW 000	PARAMETER ENABLE SWITCH ON	Parameter setting is enabled (PWE, a bit of parameter No. 8000 is 1)	

Number	Message displayed on CRT	Contents	Remarks
OT 001	+OVERTRAVEL (SOFT1)	This alarm occurs in the following cases: <ul style="list-style-type: none"> While moving in a positive direction, the tool exceeded the limit set in stored stroke limit 1. While moving in the positive direction of a hypothetical axis, the tool exceeded the limit set in the hypothetical axis stroke limit. While moving in the positive direction of a hypothetical axis, the eccentric tool length (R) was exceeded. 	Axis type
OT 002	-OVERTRAVEL (SOFT1)	This alarm occurs in the following cases: <ul style="list-style-type: none"> While moving in a negative direction, the tool exceeded the limit set in stored stroke limit 1. While moving in the negative direction of a hypothetical axis, the tool exceeded the limit set in the hypothetical axis stroke limit. While moving in the negative direction of a hypothetical axis, the eccentric tool length (R) was exceeded. 	Axis type
OT 003	+OVERTRAVEL (SOFT2)	While moving in a positive direction, the tool exceeded the limit set in stored stroke limit 2, or the tool entered the out-of-bounds chuck/tool stock area.	Axis type
OT 004	-OVERTRAVEL (SOFT2)	While moving in a negative direction, the tool exceeded the limit set in stored stroke limit 2, or the tool entered the out-of-bounds chuck/tool stock area.	Axis type
OT 005	+OVERTRAVEL (SOFT3)	While moving in a positive direction, the tool exceeded the limit set in stored stroke limit 3.	Axis type T
OT 006	-OVERTRAVEL (SOFT3)	While moving in a negative direction, the tool exceeded the limit set in stored stroke limit 3.	Axis type T
OT 007	+OVERTRAVEL (HARD)	The stroke limit switch located at the positive side was turned on.	Axis type
OT 008	-OVERTRAVEL (HARD)	The stroke limit switch located at the negative side was turned on.	Axis type
OT 021	+OVERTRAVEL (PRE-CHECK)	The tool exceeded the limit in the positive direction during the stroke check before movement.	Axis type
OT 022	-OVERTRAVEL (PRE-CHECK)	The tool exceeded the limit in the negative direction during the stroke check before movement.	Axis type
OT 030	EXCESS ERROR ALARM 1	Alarm 1 for excess synchronous error was generated.	Axis type
OT 031	SYNCHRONIZE ADJUST MODE	The system is in synchronous adjustment mode (bit 1 of parameter No. 1803 is set to 1).	Axis type

Number	Message displayed on CRT	Contents	Remarks
OT 032	NEED ZRN (ABS PCDR)	The counter value of the absolute pulse coder does not match the machine coordinates.	Axis type
OT 034	BATTERY ZERO (ABS PCDR)	The battery voltage of the absolute pulse coder is 0 V. Check whether the battery is connected properly. If the battery is connected properly, replace it.	Axis type
O T036	BATTERY DOWN (SPLC)	The battery voltage of the serial pulse coder is low. (Built-in unit)	
O T037	BATTERY DOWN (EX)	The battery voltage of the additional detector is low. (Separate unit)	
O T038	BATTERY ZERO (SPLC)	The serial pulse coder battery voltage is 0 V. (Built-in unit)	
O T039	BATTERY ZERO (EX)	The serial pulse coder battery voltage is 0 V. (Separate unit)	
OT 100	SPINDLE ALARM	The spindle motor alarm was generated, but the code for specifying the cause of the alarm is 0.	
OT 101	SPINDLE MOTOR OVERHEAT	The spindle motor overheated.	
OT 102	EXCESS VELOCITY ERROR	The difference between the speed set for the spindle motor and the actual speed of the spindle motor was too great (15% to 20%).	
OT 103	FUSE F7 BLEW	Fuse F7 for the speed control unit of the spindle motor has blown.	
OT 104	FUSE F1, F2 OR F3 BLEW	Fuse F1, F2, or F3 for the speed control unit of the spindle motor has blown.	
OT 105	FUSE AF2 OR AF3 BLEW	Fuse AF2 or AF3 for the speed control unit of the spindle motor has blown.	
OT 106	EXCESS VELOCITY (ANALOG)	The speed of the spindle motor exceeded the maximum rating (analog detection).	
OT 107	EXCESS VELOCITY (DIGITAL)	The speed of the spindle motor exceeded the maximum rating (digital detection).	
OT 108	VOLTAGE (+24V) TOO HIGH	The voltage of the 24 V power supply for the speed control unit of the spindle is too high.	
OT 109	POWER SEMICONDUCTOR OVERLOAD	The power semiconductor overheated.	
OT 110	VOLTAGE (+15) TOO LOW	The voltage of the 15 V power supply for the speed control unit of the spindle motor is too low.	
OT 111	VOLTAGE EXCESS (DC LINK)	The voltage in the DC link for the speed control unit of the spindle motor is too high.	
OT 112	CURRENT EXCESS (DC LINK)	The current in the DC link for the speed control unit of the spindle motor is excessive.	
OT 113	CPU ERROR	The CPU or a peripheral circuit of the speed control unit of the spindle motor is faulty.	
OT 114	ROM ERROR	The ROM of the speed control unit of the spindle motor is faulty.	
OT 115	OPTION ALARM	Optional alarm for the spindle motor.	
OT 116	DISCONNECTION POS CODER	The position coder is disconnected.	
OT 117	SPINDLE OVERHEAT	Spindle alarm was detected by the function for detecting fluctuations in spindle speed.	
OT 120	UNASSIGNED ADDRESS (HIGH)	The upper four bits (EIA4 to EIA7) of an external data I/O interface address signal are set to an undefined address (high bits).	
OT 121	UNASSIGNED ADDRESS (LOW)	The lower four bits (EIA0 to EIA3) of an external data I/O interface address signal are set to an undefined address (low bits).	
OT 122	TOO MANY MESSAGES	Requests were made to display more than four external operator messages or external alarm messages at the same time.	
OT 123	MESSAGE NUMBER NOT FOUND	An external operator message or external alarm message cannot be cancelled because no message number is specified.	

Number	Message displayed on CRT	Contents	Remarks
OT 124	OUTPUT REQUEST ERROR	An output request was issued during external data output, or an output request was issued for an address that has no output data.	
OT 125	TOO LARGE NUMBER	A number outside of the range 0 to 999 was specified as the number for an external operator message or an external alarm message.	
OT 126	SPECIFIED NUMBER NOT FOUND	This alarm occurs in the following cases: <ul style="list-style-type: none"> – The number specified for a program number or sequence number search during external data input could not be found. – The number specified for a workpiece number search could not be found. – There was an I/O request issued for a pot number or offset (tool data), but either no tool numbers have been input since power-on or there is no data for the entered tool number. 	
OT 127	DI. EIDHW OUT OF RANGE	The value input by external data input signals EID32 to EID47 is out of range.	
OT 128	DI. EIDLL OUT OF RANGE	The value input by external data input signals EID0 to EID31 is out of range.	
OT 129	NEGATE POS CODER 1 REV ON	The CPU or a peripheral circuit of the position coder is faulty.	
OT 130	SEARCH REQUEST NOT ACCEPTED	No requests can be accepted for a program No. or sequence No. search because the system is not in memory mode or the reset state.	
OT 131	EXT-DATA ERROR (OTHER)	<ul style="list-style-type: none"> · An input request was received for a pot No. or offset value while tool data was being registered with G10. · An error occurred during reading or writing of tool data. 	
OT 132	RETURN ERROR (PTRR)	The tool did not return to the stored position along the axis in tool retraction mode.	Axis type
OT 150	A/D CONVERT ALARM	The A/D converter is faulty.	
OT 151	A/D CONVERT ALARM	The A/D converter is faulty.	
OT 184	PARAMETER ERROR IN TORQUE	An invalid parameter was specified for torque control. (1) The torque constant parameter is set to 0.	
OT 200	INTERFERENCE DATA ERROR	The tool figure data specified for the tool post interference check is incorrect (I > X or K > Z in tool figure data).	TT
OT 208	INTERFERENCE X1 MINUS	An interference alarm occurred while the first tool post was moving in the negative direction along the X axis.	TT
OT 209	INTERFERENCE X1 PLUS	An interference alarm occurred while the first tool post was moving in the positive direction along the X axis.	TT
OT 210	INTERFERENCE Z1 MINUS	An interference alarm occurred while the first tool post was moving in the negative direction along the Z axis.	TT
OT 211	INTERFERENCE Z1 PLUS	An interference alarm occurred while the first tool post was moving in the positive direction along the Z axis.	TT
OT 212	INTERFERENCE X2 MINUS	An interference alarm occurred while the second tool post was moving in the negative direction along the X axis.	TT
OT 213	INTERFERENCE X2 PLUS	An interference alarm occurred while the second tool post was moving in the positive direction along the X axis.	TT
OT 214	INTERFERENCE Z2 MINUS	An interference alarm occurred while the second tool post was moving in the negative direction along the Z axis.	TT
OT 215	INTERFERENCE Z2 PLUS	An interference alarm occurred while the second tool post was moving in the positive direction along the Z axis.	TT
OT 300	S-SPINDLE LSI ERROR	An error occurred in communication with the spindle.	
OT 301	MOTOR OVERHEAT	Motor overheat	

Number	Message displayed on CRT	Contents	Remarks
OT 302	EX DEVIATION SPEED	Excessive deviation in speed	
OT 307	OVER SPEED	Excessive speed	
OT 309	OVERHEAT MAIN CIRCUIT	Excessive load on the main circuit	
OT 310	LOW VOLT INPUT POWER	Low voltage in the input power supply	
OT 311	OVERVOLT POW CIRCUIT	Excessive voltage in the DC link	
OT 312	OVERCURRENT POW CIRCUIT	Excessive current in the DC link	
OT 313	DATA MEMORY FAULT CPU	Error in CPU internal data memory	
OT 318	SUMCHECK ERROR PGM DATA	Sum check error in program ROM	
OT 319	EX OFFSET CURRENT U	Excessive offset in U-phase current detection circuit	
OT 320	EX OFFSET CURRENT V	Excessive offset in V-phase current detection circuit	
OT 324	SERIAL TRANSFER ERROR	Error in serial data transfer	
OT 325	SERIAL TRANSFER STOP	Serial data transfer was stopped.	
OT 326	DISCONNECT C-VELO DETCT	The Cs axis control speed detection signal is disconnected.	
OT 327	DISCONNECT POS-CODER	The position coder signal is disconnected.	
OT 328	DISCONNECT C-POS DETCT	The Cs axis control position detection signal is disconnected.	
OT 329	OVERLOAD	Temporary overload	
OT 330	OVERCURRENT POW CIRCUIT	Excessive current in input circuit	
OT 331	MOTOR LOCK OR V-SIG LOS	The motor locked up alarm is issued or the speed detection signal is disconnected.	
OT 332	RAM FAULT SERIAL LSI	Faulty RAM exists in LSI for serial data transfer.	
OT 333	SHORTAGE POWER CHARGE	Insufficient power charge in DC link	
OT 334	PARAMETER SETTING ERROR	Parameter data is out of range.	
OT 335	EX SETTING GEAR RATIO	An excessive gear ratio was set.	
OT336	OVERFLOW ERROR COUNTER	The error counter overflowed.	
OT 399	S-SPINDLE ERROR	A miscellaneous spindle amplifier alarm occurred.	
OT 512	EXCESS VELOCITY	The feedrate specified during polar coordinate interpolation mode (G12.1) was greater than the maximum cutting feedrate.	
OT 513	SYNC EXCESS ERROR	The difference between the positional deviations for the synchronized axes during simple synchronization was greater than the limit set in parameter.	Axis type
OT513	SYNC EXCESS ERROR	The difference between the master and slave axes to be synchronized with each other has exceeded the maximum compensation value.	Axis type

Number	Message displayed on CRT	Contents	Remarks
PC 010	PC ERROR	A parity error occurred in a PMC ROM.	
PC 020	PC ERROR	A parity error occurred in a PMC RAM.	
PC 030	PC ERROR	An I/O unit was not allocated correctly.	
PC 500	WATCH DOG ALARM	A PMC watch dog alarm occurred.	

Number	Message displayed on CRT	Contents	Remarks
SV 000	TACHOGENERATER DISCONNECT	The tachogenerator is disconnected.	Axis type
SV 001	EXCESS CURRENT IN SERVO	The servo motor was overloaded.	Axis type
SV 002	BREAKER (FEED_CTL_UNIT) OFF	The breaker for the velocity control circuit tripped.	Axis type
SV 003	ABNORMAL CURRENT IN SERVO	Excessive current was detected in the velocity control circuit.	Axis type
SV 004	EXCESS V TO MOTOR	Excessive voltage was detected in the velocity control circuit.	Axis type
SV 005	EXCESS DISCHARGE I FROM MOTOR	Excessive discharge current from the motor was detected in the velocity control circuit.	Axis type
SV 006	VELOCTY UNIT POWER TOO LOW	Low voltage was detected in the velocity control circuit.	Axis type
SV 008	EXCESS ERROR (STOP)	Position deviation when stopped is larger than the value set in parameter No. 1829.	Axis type
SV 009	EXCESS ERROR (MOVING)	Position deviation while moving is larger than the value set in parameter No. 1828.	Axis type
SV 010	EXCESS DRIFT COMPENSATION	Drift compensation is excessive (exceeded 500VELO).	Axis type
SV 011	LSI OVERFLOW	The value specified for position deviation compensation is not within the range of -32767 to +32767, or the command value of the D/A converter is not within the range of -8192 to +8192. In general, this alarm occurs due to incorrect settings.	Axis type
SV 012	MOTION VALUE OVERFLOW	A speed greater than 512,000 pulses per second (frequency converted into detection units) was specified. In general, this alarm occurs due to incorrect setting of parameter CMR or the feedrate.	Axis type
SV 013	IMPROPER V-READY OFF	The speed control ready signal (VRDY) went off even though the position control ready signal (PRDY) was on. When a multiaxis amplifier is being used, specifying controlled axis detachment for any axis driven by the amplifier causes alarm SV013 to be issued for the other axes driven by that amplifier.	Axis type
SV 014	IMPROPER V-READY ON	The speed control ready signal (VRDY) went on even though the position control ready signal (PRDY) was off.	Axis type
SV 015	PULSE CODER DISCONNECTED	The pulse coder is disconnected.	Axis type
SV 017	ILL POSITION CONTROL LSI	A fault occurred in the LSI for position control.	Axis type
SV 018	INCORRECT DSCG FREQUENCY	A fault was detected in a resolver or inductsyn feedback frequency check.	Axis type
SV 019	INCORRECT PULSE CODER PULSE	A fault was detected in the feedback pulse from the pulse coder.	Axis type
SV 020	INCORRECT PHASE SHIFT VALUE	The resolver or induction phase shift cannot be obtained correctly.	Axis type
SV 021	1-REV PULSE SIGNAL INCORRECT	The single-revolution signal for the pulse coder went on at an incorrect position.	Axis type
SV 022	1-REV PULSE MISSING	The single-revolution signal for the pulse coder did not go on within the appropriate range.	Axis type
SV 023	SV OVERLOAD	A servo motor overloaded.	Axis type
SV 024	EXCESS ERROR ALARM 2	Alarm 2 for excess synchronous error was generated.	
SV 025	V-READY ON (INITIALIZING)	During servo control, the speed control ready signal (VRDY) is on even though it is supposed to be off.	Axis type

Number	Message displayed on CRT	Contents	Remarks
SV 026	ILLEGAL AXIS ARRANGEMENT	Parameter No. 1023 for specifying the arrangement of servo axes is set incorrectly.	
SV 027	ILL DGTL SERVO PARAMETER	There is an illegal digital servo parameter. <ul style="list-style-type: none"> – A correct motor model type is not set in parameter No. 1874. – The number of pulses per motor rotation is not set in parameter No. 1876. – The direction of motor rotation set in parameter No. 1879 is neither 111 nor –111. 	
SV 030	EMERGENCY STOP	Emergency stop occurred (when ENR, a bit of parameter No. 2001, is 1).	
SV 031	EXCESS SPINDLE DIST (SPDL)	Excess position deviation occurred for the spindle during rigid tapping.	
SV 032	LSI OVERFLOW (SPDL)	Data for the LSI used for spindle control overflowed during rigid tapping.	
SV 050	ILLEGAL AXIS SYNCHRONIZATION	Parameter No. 1023 is set incorrectly.	
SV 055		Parameter No. 1023 is set incorrectly.	
SV 056		Bit #6 of parameter No. 1817 is set incorrectly.	
SV 99	SPINDLE-AXIS ERROR	An amplifier alarm occurred during spindle contour control.	
SV 100	SACOMP, VALUE OVERFLOW	The value set for straightness compensation is not within the range of –32767 to +32767.	M
SV 101	DATA ERROR (ABS PCDR)	A correct machine position cannot be obtained because the absolute pulse coder is faulty or the machine moved too far during power-on.	Axis type
SV 110	PULSE CORDER ALARM (SERIAL A)	An error was detected in the serial pulse coder (serial A) or feedback cable. Replace the cable or pulse coder. (For details on the alarm, refer to the “FANUC AC Servo Amplifier Maintenance Manual.”)	Axis type
SV 111	PULSE CORDER ALARM (SERIAL C)	An error was detected in the serial pulse coder (serial C) or feedback cable. Replace the cable or pulse coder. (For details on the alarm, refer to the “FANUC AC Servo Amplifier Maintenance Manual.”)	Axis type
SV 114	ABNORMAL REV. DATA (SERIAL A)	The serial pulse coder (serial A) is abnormal. Replace it.	Axis type
SV 115	ABNORMAL COMMUNICATION (SPLC)	A serial pulse coder communication failure occurred. Replace the pulse coder, feedback cable, or CNC axis board.	Axis type
SV 116	MCC WELDING ARARM	The contact of the magnetic contractor (MCC) in the servo amplifier has melted. For details, refer to the “FANUC AC Servo Amplifier Maintenance Manual.”	Axis type
SV 117	ABNORMAL CURRENT OFFSET	Digital servo current conversion is abnormal. Replace the CNC axis board.	Axis type
SV 118	DETECT ABNORMAL TORQUE	An abnormal servo motor load was detected. Reset to clear the alarm.	Axis
SV 119	DETECT ABNORMAL TORQUE (1ST SPDL)	An abnormal load was detected on the first spindle motor. To reset the alarm, press the RESET button.	
SV 125	EXCESS VELOCITY IN TORQUE	In torque control, the specified maximum allowable velocity was exceeded.	
SV 126	EXCESS ERROR IN TORQUE	In torque control, the maximum allowable accumulated movement, specified with a parameter, was exceeded.	

Number	Message displayed on CRT	Contents	Remarks
SV 323	DISCONNECT ALARM BY SOFT	Disconnection of the serial pulse coder was detected. (Software)	
SV 324	DISCONNECT ALARM BY HARD	Disconnection of the serial pulse coder was detected. (Hardware)	
SV 325	PULSE CODER ALARM1 (SPLC)	An abnormality was detected in the serial pulse coder or feedback cable. (Built-in unit)	
SV 326	PULSE CODER ALARM3 (SPLC)	An abnormality was detected in the serial pulse coder or feedback cable. (Built-in unit)	
SV 327	ABNORMAL REV. DATA (SPLC)	The serial pulse coder is abnormal. Replace the pulse coder. (Built-in unit)	
SV 330	ABNORMAL COMMUNICATION (SPLC)	A serial pulse coder communication error occurred. (Built-in unit)	
SV 331	PULSE CODER ALARM2 (SPLC)	An abnormality was detected in the serial pulse coder or feedback cable. (Built-in unit)	
SV 333	PULSE CODER ALARM4 (EX-LIN)	An abnormality was detected in the serial pulse coder or feedback cable. (Separate linear)	
SV 334	PULSE CODER ALARM5 (EX-ROT)	An abnormality was detected in the serial pulse coder or feedback cable. (Separate rotary)	
SV 335	ABNORMAL REV. DATA (EX-ROT)	The serial pulse coder is abnormal.	
SV 336	BATTERY ZERO (EX)	The serial pulse coder battery voltage is 0 V. (Separate unit)	
SV 338	DETECTOR OVER LOAD (EX)	The serial pulse coder is overloaded. (Separate unit)	
SV 339	ABNORMAL COMMUNICATION (EX)	A communication error occurred in the serial pulse coder. (Separate unit)	
SV 340	PULSE CODER DISCONNECT (EX)	Disconnection of the serial pulse coder was detected. (Separate unit)	

Number	Message displayed on CRT	Contents	Remarks
IO 030	CHECK SUM ERROR	The check sum for a page of NC memory is incorrect.	
IO 031	INVALID CODE	An invalid code was read from NC memory.	
IO 032	OUT OF RANGE MEMORY ACCESS	An attempt was made to read data from or write data to an address outside of bubble memory.	

Number	Message displayed on CRT	Contents	Remarks
PW 000	POWER MUST BE OFF	A parameter was set for which the power must be turned off then on again.	
PW 100	ILLEGAL PARAMETER	The parameter for setting straightness compensation or the parameter for setting inclination compensation is specified incorrectly.	

C.2

(1)PMC-NA

ALARM LIST (PMC)

Message	Alarm description
THERE IS NO ALARM	Normal condition. Machine usually operates under this condition.
ER01 ROM CASSETTE ROM PARITY	ROM PARITY occurred in the FLASH ROM. (PMC-NA) Corrective action: Refer to the Chapter III-7.5 "Data Input/Output From/To RAM Board (PMC-NA)" in the Programming Manual of FANUC PMC-N/NA (B-61013E).
ER02 PROGRAM DATA ERROR	Sequence data is wrong or corrupt.
ER03 PROGRAM SIZE ERROR	Sequence data exceeding the print board capacity was input.
ER04 SERIES UNMATCH	Sequence data of another series was input. Note) In this case, a ladder program cannot run.
ER10 TCB SETTING ERROR	The task entry address setting. Stack address, level, or starting condition parameter is incorrect.
ER11 NO C LIBRARY OPTION	There is no C library option.
ER12 PASCAL DATA ORIGIN ERROR	Another data area is used instead of the PASCAL DATA AREA, or an odd number address is set.
ER13 PASCAL ORIGIN ERROR	Another area is used instead of the PASCAL AREA, or an odd number address is set.
ER21 SLC ERROR	The I/O Link LSI is defective. Corrective action: Change the PMC print board.
ER22 SLC ERROR (xGROUP)	LSI detection of an I/O device has occurred in the x group, or abnormal communication has occurred. Corrective action: Replace the print board or the I/O device.
ER23 SLOT SETTING ERROR	An attempt was made to specify 11 or greater as a slot number.
ER24 TOO MUCH DATA (xGROUP INPUT)	More than 33 bytes were allocated to the input x group.
ER24 TOO MUCH DATA (xGROUP OUTPUT)	More than 33 bytes were allocated to the output x group.
ER25 I/O SETTING ERROR (xGROUP INPUT)	Insufficient I/O area (allocation after the output x group is invalid).
ER25 I/O SETTING ERROR (xGROUP OUTPUT)	Insufficient I/O area (allocation after the output x group is invalid).
ER26 I/O DEVICES ARE UNLINKED (AFTER xGROUP)	I/O devices are connected only up to the (x-1) group although allocation data is created for the x and subsequent groups. Note) If the system is started, the ladder program is not automatically executed. (Pressing the "RUN" key, however, executes the ladder program.) Corrective action: Correct I/O device allocation, or check the I/O device configuration.

Message	Alarm description
ER27 I/O DEVICES ARE UNDEFINED (AFTER xGROUP)	The I/O allocation data is created for only up to the (x-1) group although I/O devices are connected to the x and subsequent groups. Note) If the system is started with the ROM cassette mounted, the ladder program is not automatically executed. (Pressing the "RUN" key, however, executes the ladder program.) Corrective action: Correct I/O device allocation, or check the I/O device configuration.
ER28 I/O ALLOCATION ERROR (xGROUP)	Because I/O UNIT Model A exists in x group, data can not be automatically allocated. Note) In this case, I/O is not inputted output. Corrective action: Press the "IOSTAT" key or power on again after making allocation data.
ER31 I/O DEVICES ARE UNLINKED (AFTER xGROUP)	I/O devices were connected only for groups "X-1" and lower, when they had been assigned for groups X and higher. In addition: Value specified at "NUMBER OF I/O LINK GROUP" on the [MODE] screen > number of connected groups Note) In this case, no sequence program is started when the power is switched on. (Pressing the [RUN] key starts a sequence program, however). Corrective action: Correct the I/O device assignment, or check the configuration of the I/O devices.
WR20 NO I/O DEVICE	An I/O device is not connected. Corrective action: Confirm the optical cable and I/O power source are properly connected.

(2) PMC-NB

Message	Contents and solution
ALARM NOTHING	Normal status
ER01 PROGRAM DATA ERROR (RAM)	The sequence program is defective. (solution) Please clear the program and input LADDER again.
ER02 PROGRAM SIZE OVER	The size of sequence program exceeds the maximum size of LADDER. (solution) Please change MAX LADDER AREA SIZE at the SYSPRM screen and restart the system.
ER03 PROGRAM SIZE ERROR (OPTION)	The size of sequence program exceeds the option specification size. (solution) Please increase the option specification size. Or, reduce the size of sequence program.
ER04 PMC TYPE UNMATCH	The PMC model setting of the sequence program is not corresponding to an actual model. (solution) Please change the PMC model setting by the offline programmer.
ER17 PROGRAM PARITY	The parity error occurred on memory for sequence program or the debugging RAM.

Message	Contents and solution
ER18 PROGRAM DATA ERROR BY I/O	Transferring the sequence program from offline programmer was interrupted by the power off etc. (solution) Please clear the sequence program and transfer the sequence program again.
ER19 LADDER DATA ERROR	Editing the LADDER was interrupted by the power off or by the switch to the CNC screen by the function key etc. (solution) Please edit LADDER once on PMC. Or, please input LADDER again.
ER20 SYMBOL/COMMENT DATA ERROR	Editing the symbol and comment was interrupted by the power off or by the switch to the CNC screen by the function key etc. (solution) Please edit symbol and comment once on PMC. Or, please input symbol and comment again.
ER21 MESSAGE DATA ERROR	Editing the message data was interrupted by the power off or the switch to the CNC screen by the function key etc. (solution) Please edit message data once on PMC. Or, please input message data again.
ER22 PROGRAM NOTHING	There is no sequence program.
ER23 PLEASE TURN OFF POWER	There is a change in setting LADDER MAX AREA SIZE etc. (solution) Please restart the system to make the change effective.
ER32 NO I/O DEVICE	Any DI/DO unit of I/O Unit or the connection unit etc. is not connected. If I/O devices, such as the I/O Unit, are in use: Make sure that power is supplied to the I/O devices. Also check the cable connection.
ER33 SLC ERROR	The LSI for I/O Link is defective. (solution) Please exchange the module of PMC engine.
ER34 SLC ERROR (xx)	The communication with the DI/DO units of the xx group failed. (solution) Please confirm the connection of the cable connected to the DI/DO units of the xx group. Please confirm whether the DI/DO units turned on earlier than CNC and PMC. Or, please exchange the module of PMC engine on the DI/DO units of the xx group.
ER35 TOO MUCH OUTPUT DATA IN GROUP (xx)	The number of the output data in the xx group exceeded the max. The data, which exceed 32 bytes, become ineffective. (solution) Please refer to the following for the number of the data for each group. "FANUC I/O Unit-MODEL A connecting and maintenance manual" (B-61813E) "FANUC I/O Unit-MODEL B connecting manual"(B-62163E)
ER36 TOO MUCH INPUT DATA IN GROUP (xx)	The number of the input data in the xx group exceeded the max. The data, which exceed 32 bytes, become ineffective. (solution) Please refer to the following for the number of the data for each group. "FANUC I/O Unit-MODEL A connecting and maintenance manual" (B-61813E) "FANUC I/O Unit-MODEL B connecting manual"(B-62163E)

Message	Contents and solution
ER38 MAX SETTING OUTPUT DATA OVER (xx)	<p>The assignment data for a group exceeds 128 bytes. (The assignment data of output side of xx group or later become ineffective.)</p> <p>(solution) Please reduce the assignment data to 128 bytes or less for the number of the output data of each group.</p>
ER39 MAX SETTING INPUT DATA OVER (xx)	<p>The assignment data for a group exceeds 128 bytes. (The assignment data of input side of xx group or later become ineffective.)</p> <p>(solution) Please reduce the assignment data to 128 bytes or less for the number of the input data of each group.</p>
WN01 LADDER MAX SIZE ERROR	<p>The MAX LADDER AREA SIZE in the system parameter is illegal.</p> <p>(solution) Set the correct value to MAX LADDER AREA SIZE and restart the system.</p>
WN02 OPERATE PANEL ADDRESS ERROR	<p>The address setting data of the operator's panel for FS-0 is illegal.</p> <p>(solution) Please correct the address setting data.</p>
WN03 ABORT NC-WINDOW/EXIN	<p>LADDER was stopped while CNC and PMC were communicating. The functional instruction WINDR, WINDW, EXIN, DISPB, and etc. may not work normally.</p> <p>(solution) When restarting the system, this alarm will be released. Execute the sequence program(Press RUN key) after confirming whether there is a problem in LADDER or not.</p>
WN07 LADDER SP ERROR (STACK)	<p>When functional instruction CALL(SUB65) or CALLU(SUB66) was executed, the stack of the LADDER overflowed.</p> <p>(solution) Please reduce the nesting of the subprogram to 8 or less.</p>
WN17 NO OPTION (LANGUAGE)	<p>There is no C language option.</p>
WN18 ORIGIN ADDRESS ERROR	<p>The LANGUAGE ORIGIN address of the system parameter is wrong</p> <p>(solution) Please set the address of symbol RC_CTLB_INIT in the map file to the LANGUAGE ORIGIN of the system parameter.</p>
WN19 GDT ERROR (BASE, LIMIT)	<p>The value of BASE, LIMIT or ENTRY of user defined GDT is illegal.</p> <p>(solution) Please correct the address in link control statement and build file.</p>
WN20 COMMON MEM. COUNT OVER	<p>The number of common memories exceeds 8.</p> <p>(solution) Please reduce the number of common memories to 8 or less. It is necessary to correct a link control statement, build file and the source file for the common memory.</p>
WN21 COMMON MEM. ENTRY ERROR	<p>GDT ENTRY of the common memory is out of range.</p> <p>(solution) Please correct the address of GDT ENTRY of the common memory in the link control statement.</p>
WN22 LADDER 3 PRIORITY ERROR	<p>The priority of LADDER LEVEL 3 is out of range.</p> <p>(solution) Please correct the value of LADDER LEVEL 3 in the link control statement within the range of 0 or 10-99 or -1.</p>
WN23 TASK COUNT OVER	<p>The number of user tasks exceeds 16.</p> <p>(solution) Please confirm TASK COUNT in the link control statement. When the number of tasks is changed, it is necessary to correct the link control statement, build file and the composition of the files to be linked.</p>

Message	Contents and solution
WN24 TASK ENTRY ADDR ERROR	The selector of the entry address to the user task is out of range. (solution) Please correct the table of GDT in build file to the value within 32(20H)–95(5FH).
WN25 DATA SEG ENTRY ERROR	The entry address of the data segment is out of range. (solution) Please correct DATA SEGMENT GDT ENTRY in the link control statement and the table of GDT in build file within 32(20H)–95(5FH).
WN26 USER TASK PRIORITY ERROR	The priority of the user task is out of range. (solution) Please correct the TASK LEVEL in link control statement within the range of 10–99 or –1. Note: Only one task can have TASK LEVEL –1 (including LADDER LEVEL 3).
WN27 CODE SEG TYPE ERROR	The code segment type is illegal. The code segment of RENAMESEG in the binding control file is wrong. (solution) Please correct the entry of the code segment in the link control statement to correspond to the entry in the build file.
WN28 DATA SEG TYPE ERROR	The data segment type is illegal. The data segment of RENAMESEG in the binding control file is wrong. (solution) Please correct the entry of the code segment in the link control statement to correspond to the entry in the build file.
WN29 COMMON MEM SEG TYPE ERROR	The segment type of common memory is illegal. The segment of RENAMESEG in the building control file of the common memory is wrong. (solution) Please correct the entry of common memory in the link control statement to correspond to the entry in the build file.
WN30 IMOPSSIBLE ALLOCATE MEM.	The memories for the data and stack etc. cannot be allocated. (solution) Please confirm whether the value of code segment in build file and USER GDT ADDRESS in link control statement is correct or not. Or please reduce the value of MAX LADDER AREA SIZE of the system parameter and the size of the stack in link control statement at the least.
WN31 IMPOSSIBLE EXECUTE LIBRARY	The library function cannot be executed. (solution) Please confirm the object model of the library. Or, system ROM of PMC must be replaced with one of later version.
WN32 LNK CONTROL DATA ERROR	Link control statement data is illegal. (solution) Please confirm whether the address of symbol RC_CTLB_INIT in map file is set to LANGUAGE ORIGIN of the system parameter. Or, please make the link control statement again.

C.3 PMC ERRORS

The following appears on the screen if an alarm condition (error) occurs:

SYSTEM ALARM

08:511D:SERI:0005:0094H581

BUS ERROR FFEC8D (005DC6):PC040

08: : Slot number
511D : ID number of printed circuit board
SERI : ROM series
0005 : ROM version
0094h581 : Last 8 digits of drawing number
BUS : Description of error (See 5.6 (2).)

(1) Error codes

Error code	Message	Description
PC010	PC ERROR	PC ROM parity error
PC020	PC ERROR	PC RAM parity error
PC030	PC ERROR	NC RAM parity error
PC040	PC ERROR	PC system error
PC050	PC ERROR	Error related to DI/DO
PC070	PC ERROR	MPC2 watch dog timer alarm
PC500	WATCH DOG ALARM	PC watch dog timer alarm

(2) System error messages

- (a) BUS ERROR (VECTOR: 08H)
Bus error (Access was made to an unusable address.)
<Message>: 31 characters

```
BUS ERROR xxxxxx (yyyyyy):PC040
```

xxxxxx: Access address
yyyyyy: Execution address

- (b) ADDRESS ERROR (VECTOR: 0CH)
Address error (Access was made to an odd-numbered address.)
<Message>: 31 characters

```
ADR ERROR xxxxxx (yyyyyy):PC040
```

xxxxxx: Access address
yyyyyy: Execution address

- (c) ILLEGAL INSTRUCTION (VECTOR: 10H)
Tried to execute an illegal instruction
<Message>: 24 characters

ILG ERROR (yyyyyy) : PC040

yyyyyy: Execution address

- (d) ZERO DIVIDE (VECTOR: 14H)
Division by 0 was attempted.
<Message>: 24 characters

ZDV ERROR (yyyyyy) : PC040

yyyyyy: Execution address

- (e) CHK INSTRUCTION (VECTOR: 18H)
Register limit check error (Register limit has been exceeded.)
<Message>: 24 characters

CHK ERROR (yyyyyy) : PC040

yyyyyy: Execution address

- (f) TRAPV INSTRUCTION (VECTOR: 1CH)
Overflow trap
<Message>: 24 characters

TRV ERROR (yyyyyy) : PC040

yyyyyy: Execution address

- (g) PRIVILEGE VIOLATION (VECTOR: 20H)
Privileged instruction violation
<Message>: 24 characters

PRV ERROR (yyyyyy) : PC040

yyyyyy: Execution address

- (h) TRACE (VECTOR: 24H)
CPU trace (hardware error)
<Message>: 24 characters

TRC ERROR (yyyyyy) : PC040

yyyyyy: Execution address

- (i) LINE 1010 EMULATOR (VECTOR: 28H)
 Tried to execute an instruction whose operation code is Axxx.
 <Message>: 24 characters

L10 ERROR (yyyyyy) : PC040

yyyyyy: Execution address

- (j) LINE 1111 EMULATOR (VECTOR: 2CH)
 Tried to execute an instruction whose operation code is Fxxx.
 <Message>: 24 characters

L11 ERROR (yyyyyy) : PC040

yyyyyy: Execution address

- (k) UNASSIGNED NMI (VECTOR: 30H~5CH)
 An interrupt occurred when it should not have (hardware error).
 <Message>: 24 characters

NAE ERROR (yyyyyy) : PC040

yyyyyy: Execution address

- (l) SPURIOUS INTERRUPT (VECTOR: 60H)
 An interrupt occurred, but its cause was not identified
 (hardware error).
 <Message>: 24 characters

SPI ERROR (yyyyyy) : PC040

yyyyyy: Execution address

- (m) UNASSIGNED TRAP (VECTOR: 88H~B0H)
 A trap occurred when it should not have (hardware error).
 <Message>: 24 characters

NTP ERROR (yyyyyy) : PC040

yyyyyy: Execution address

- (n) ROM PARITY (VECTOR: B4H)
 PMC ROM parity error (PMC control ROM error)
 <Message>: 20 or 24 characters

ROM PARITY zzz yyy:PC010

zzz, yyy: ROM number

(o) CNC SYSTEM ERROR (VECTOR: B8H)
 CNC system error
 <Message>: None

(p) TRAP15 (VECTOR: BCH)
 I/O error in battery powered RAM
 (printed circuit board BASE0 faulty)
 <Message>: 24 characters

```
T15 ERROR (yyyyyy) : PC040
```

yyyyyy: Execution address

(q) RAM PARITY (VECTOR: 7CH)
 Memory error (PMC NA faulty)
 <Message>: 36 characters

```
RAM ERROR <B.RAM> xx (yyyyyy) : PC020
      <O.RAM>
      <S.RAM>
      <P.RAM>
      <K.RAM>
```

B. RAM: BASIC RAM

O. RAM: OPTIONAL DRAM

S. RAM : SRAM

P. RAM : PMC RAM board

K. RAM: PMC DATA (battery-powered RAM area)

XX : Detailed information about RAM parity error

bit 0 : Error occurred when the lower byte of the DRAM serial port was read.

bit 1 : Error occurred when the upper byte of the DRAM serial port was read.

bit 2 : Error occurred when the lower byte of the DRAM RAM port was read.

bit 3 : Error occurred when the upper byte of the DRAM RAM port was read.

bit 4 : RAM type (0 = Basic RAM, 1 = Optional RAM)

bit 5 : Error occurred when SRAM was read.

bit 6 : bit 7 bit 6

bit 7 : 0 0 : Error occurred during host access.

0 1 : Error occurred during BOC access.

1 0 : Error occurred during direct memory access.

1 1 : BOC racing error during direct memory access.

yyyyyy : Execution address

(r) SLC ERROR (VECTOR: 7CH)
I/O communication error
<Message>: 22 characters

SLC ERROR xx (yy):PC050

xx : Detailed information on host SLC error
bit 0 : CRC error or framing error
(detection of an error such as a reversed bit)
bit 1 : Error detected by the slave unit
bit 2 : Communication error
bit 3 : Internal parity error
bit 4 : External parity error
bits 5 to 7 : Undefined
yy : Detailed information on slave SLC error
bits 0 to 4 : Serial alarm number
bit 5 : CRC error or framing error detected by the slave unit
bit 6 : Error detected by the slave unit
bit 7 : Watch dog timer alarm or parity error detected by the
slave unit

NOTE

Subtracting 1 from this number yields the I/O group number. Assume "00011" is displayed. $3 - 2 = 2$. Therefore, the alarm occurred in an I/O device in group 2. Note, however, that this information is valid only when bits 0 and 1 of xx (host SLC error detail information) are 1.

(3)PMC-NA

	Display error messages	Error contents
1	ROM PARITY add bbb : PC010	PMC ROM parity error has occurred aaa,bbb: defecitive ROM number
2	RAM PARITY <a.RAM> bb (yyyyyy) : PC020	PMC RAM parity error has occurred a. RAM: kind of RAM PARITY (B.RAM: BASIC RAM, O.RAM: OPTION RAM S.RAM: STATIC RAM and P.RAM: PMC RAM boards) bb: RAM PARITY ERROR information
3	BUS ERROR xxxxxx (yyyyyy) : PC040	Bus error (impossible to use address access) has occurred
4	ADR ERROR xxxxxx (yyyyyy) : PC040	Address error (odd number address access) has occurred
5	ILG ERROR (yyyyyy) : PC040	Attempted to execute execution-impossible command
6	ZDV ERROR (yyyyyy) : PC040	Tried to execute division with a divisor of zero
7	CHK (yyyyyy) : PC040	Register has exceeded the range in the register limit check
8	TRV (yyyyyy) : PC040	Overflow trap has occurred
9	PRV (yyyyyy) : PC040	Privilege command violation error has occurred
10	TRC (yyyyyy) : PC040	CPU has entered the trace status
11	L10 (yyyyyy) : PC040	Attempted to execute a command with the command code appearing to be Axxx
12	L11 (yyyyyy) : PC040	Attempted to execute a command with the command code appearing to be Fxxx
13	NAE (yyyyyy) : PC040	Unexpected interruption has occurred
14	SPI (yyyyyy) : PC040	Interruption whose cause is unclear has occurred
15	NTP (yyyyyy) : PC040	Unexpected TRAP has occurred
16	SLC ERROR aa : PC040	Abnormality in DI/DO has occurred aa: DI/DO ERROR information
17	PC500 WATCH DOG ALARM	PMC watchdog alarm has occurred

(xxxxxx:access address; yyyyyy: execution address)

(4)PMC-NB

Message STATUS LED	Contents and solution
RAM ERROR <a> bbcc xxxx: yyyyyyy: PC010 STATUS LED ☆■ or □☆	The parity error occurs on the debugging RAM of PMC. a : RAM which generates RAM parity. B BASIC RAM O OPTION RAM S STATIC RAM bb, cc : RAM PARITY information. xxxx : Segment selector where system error occurred. yyyyyyy : Offset address where system error occurred.
ROM ERROR aaaaaaa: PC020 STATUS LED ☆☆	The parity error occurs in PMC system ROM. aaaaaaa : ROM parity information
DIVIDE ERROR xxxx: yyyyyyy: PC040 STATUS LED ☆☆	Division error occurs such as a divisor is 0 in the division instruction. xxxx : Segment selector where system error occurred. yyyyyyy : Offset address where system error occurred.
BUS ERROR xxxx: yyyyyyy: PC040 STATUS LED ☆☆	The BUS error (access on illegal address). xxxx : Segment selector where system error occurred. yyyyyyy : Offset address where system error occurred.
STACK FAULT xxxx: yyyyyyy: PC040 STATUS LED ☆☆	The stack exception such as the violation of the limit of the stack. xxxx : Segment selector where system error occurred. yyyyyyy : Offset address where system error occurred.
GENERAL PROTECTION xxxx: yyyyyyy: PC040 STATUS LED ☆☆	The general protection exception such as segment limit over was generated. xxxx : Segment selector where system error occurred. yyyyyyy : Offset address where system error occurred.
SLC ERROR aa (cc) : PC050 STATUS LED ■☆	The communication error occurred in the I/O Link. aa, cc : I/O Link error information. This error may occur by the following causes. 1. When I/O Unit-MODEL A is used, base1, 2 or 3 is not connected though allocated. 2. The connection of cable is insufficient. 3. Defects of cable. 4. Defects of DI/DO units (I/O unit, Power Mate etc.) 5. Defects of PMC board (printed circuit board on host side where I/O Link cable is connected.) (solution) Investigate the cause of error. 1. Please confirm the allocation data (by “EDIT”→“MODULE” screen) and compare with the actual connection. 2. Please confirm whether the cable is correctly connected. If you cannot find the cause with the ways above, it may be the defect of hardware. Please investigate a defective place by the following methods. 3. Please confirm the specification of the cable referring to “FANUC I/O Unit-MODEL B connecting manuals(B-62163E)”. 4. Exchange the interface module of I/O Unit, the cable and the PMC board, etc. one by one and, confirm whether this error occurs again. The communication may fail by the noise etc. when this error still occurs after replacing all DI/DO units. Please investigate the cause of noise.

STATUS LED (green) are LED1, LED2 on PMC-NB.

□ : Off ■ : On ☆☆ : Blinking

D WARNING MESSAGE LIST

Message	Alarm description
PARAMETER/SETTING DATA/MACRO VARIABLE CAN'T REWRITE (MDI EXECUTING)	Because MDI operation is being performed, neither parameters, setting data, nor macro variables can be rewritten.
PARAMETER/SETTING DATA/MACRO VARIABLE CAN'T REWRITE (RESETTING)	Because reset operation is being performed, neither parameters, setting data, nor macro variables can be rewritten.
PARAMETER/SETTING DATA/MACRO VARIABLE CAN'T REWRITE (MODE CHANGING)	Because mode switching is being performed, neither parameters, setting data, nor macro variables can be rewritten.
KEY IN DATA	Enter data with keys.
FORMAT ERROR	The format is illegal.
WRITE PROTECT (MEMORY PROTECTION KEY IN EFECT)	Input is disabled because the memory protection key (workpiece coordinates, offset values, and programs) is on.
WRITE PROTECT (DATA NUMBER 8000#0/PWE IS 0)	Parameter input is disabled because PWE (bit 0) of parameter No. 8000 (enable/disable parameter write) is set to 0.
CHANGE TO MDI MODE	An attempt was made to input parameters in mode other than the MDI mode. Place the system in the MDI mode.
DATA IS OUT OF RANGE	An attempt was made to input a value, but the value exceeded the allowable range.
TOO MANY DIGITS	An attempt was made to input a value, but it was longer than the maximum allowable number of digits.
START REJECT	The start of automatic operation is not accepted. (1) Automatic operation pause signal *SP is low. (2) An alarm exists. (3) The SRN signal has been sent. (4) The program the operator wants to execute is now being edited in the background. (5) PTR is not ready in the tape mode.
LOCKED PARAMETER	An attempt was made to enter data for a parameter, but input for that parameter was not allowed.
DATA NOT FOUND	Data is missing.
DEVICE IS ALREADY IN USE	The external input/output device channels are being used, so a device cannot be used unless the operation is terminated. To release this state, reset the system.
NO PROGRAM SELECTED	Although no program was selected, an attempt was made to perform editing. Before editing, select a program by searching for its program number or registering the program.

Message	Alarm description
ORIGIN IMPOSSIBLE (IN RESET OR FEED HOLD)	ORIGIN operation is disabled because the system is in the reset or feed hold state.
EDIT REJECT (IN RESET OR FEEDHOLD)	Editing is disabled because the system is in the reset or feed hold state. Release the reset or feed hold state.
EDIT REJECT (PROGRAM IN OPERATING)	Editing of a program is disabled because that program is currently running.
ALREADY EXISTS	An attempt was made to register a new program with an existing program number.
NO MORE PROGRAM CAN'T BE ENTERED	Because the program memory area is full, no more programs can be registered.
NOT EMERGENCY STOP	An attempt was made to register parameters in a state other than the emergency stop state. Place the system in the emergency stop state.
THE NUMBER OF PROGRAMS IS OUT OF RANGE	Because the number of registered programs has reached the maximum allowable number, no more programs can be registered.
GUARDED WORD	An attempt was made to edit a word that cannot be edited. For example, this message appears when an attempt is made to alter or delete a program number.
NO PROGRAM NUMBER	An attempt was made to write a program to tape, but no program number was found at the beginning of the program.
COMMAND ILLEGAL USE	The command cannot be used in the current CNC status. (This message appears when HERE is specified at the beginning in program verification or when a program restart is specified during program restart operation.)
BACKGROUND EDIT REJECT (PROGRAM IN OPERATING)	Although a program was running in the background, an attempt was made to edit that program.
BACKGROUND EDIT REJECT (SAME PROGRAM ON THE FOREGROUND)	An attempt was made to edit a program in the background, but the program was being used in the foreground. (The program, however, can be edited in the background when the program is being reset and rewound in the foreground.)
INVISIBLE PROGRAM	The cursor was used to select a program, or an attempt was made to edit a program, but the program could not be displayed (when a parameter is set to suppress the display of that program during operation or when the program is encrypted).
NO OPTION	No option is given to a specified command.
GRAPHIC AXIS NUMBER NOT SET	The parameter for selecting the graphic display axis (parameter No. 7703) is not set.
FAIL TO OCCUPY GRAPHIC CPU	Another user (such as the PC) tried to use the graphic CPU.
EXTERNAL WORKPIECE ZERO NOT INPUT	Workpiece zero point manual setting was performed on the external workpiece zero point offset.
+OVERTRAVEL(SOFT1)	The tool has attempted to enter an area set as inhibited by stored stroke limit 1 during manual movement in the positive direction. Backing out the tool in the negative direction automatically clears this warning message.

Message	Alarm description
-OVERTRAVEL(SOFT1)	The tool has attempted to enter an area set as inhibited by stored stroke limit 1 during manual movement in the negative direction. Backing out the tool in the positive direction automatically clears this warning message.
CAN NOT REPEAT (BUFFER IS EMPTY)	An attempt was made to use the repeat search function when neither the forward nor backward search function had been executed. Before using the repeat search function, execute either the forward or backward function.
CAN NOT REPEAT (FUNCTION IS DIFFERENT)	The previous forward or backward search operation was invalid for the NC mode screen on which you attempted to use the repeat search function. Retry the forward or backward search function by starting from scratch.
ALREADY EXISTS	On the signal selection screen, an attempt was made to newly register a previously registered address.

《Numbers》

10" LCD, 185, 187
 10" PDP, 186
 15-MFB data input/output, 222
 9.5" LCD, 185
 9.5" LCD, 10.4" LCD (graphic function built-in type or for MMC-IV), 187
 9" PDP, 186

《A》

Action against noise, 86
 Address, 227
 Adjusting the liquid-crystal display, 185
 Alarm 700 (overheat at control side), 321
 Alarm history display, 13
 Alarm history screen, 13
 Alarm LED (red) display in the event of an error occurring in the connection unit/operator's panel connection unit, 161
 Alarm LED display (red) in the event of an error, 160
 Alarm list (CNC), 364
 Alarm list (PMC), 383
 Alarm OT117 (spindle speed fluctuation detection alarm), 322
 Alarm OT300 (spindle serial link cannot be started), 323
 Alarm OT32 (need ZRN (ABS PDR)), 314
 Alarm OT34 (battery zero (ABS PCDR)), 316
 Alarm SV101 (data error (ABS PCDR)), 315
 Alarm SV110 (pulse coder alarm1 (serial)), 317
 Alarm SV114 (abnormal rev data), 317
 Alarm SV115 (abnormal communication (serial PCDR)), 318
 Alarm SV23 (SV over load), 319
 Automatic operation cannot be done, 288

《B》

Back panel PCB, 165
 Boot system, 335
 Built-in debug function, 228

《C》

Checking the parameters required for data input/output, 200
 CNC parameter input, 214
 CNC parameter output, 208
 Combining serial spindle and analog spindle, 79
 Configuration of additional axis (ADAX) board, 149
 Configuration of the axis CPU board (ACPU), 130
 Configuration of the CPU board (MAIN-B), 96
 Configuration of the high-speed multiaxis main CPU board (MAX MAIN-A), 107

Configuration of the level up multiaxis main CPU board (MAX MAIN-C), 111
 Configuration of the main CPU board (MAIN-A), 100
 Configuration of the multiaxis buffer board, 133
 Configuration of the option 1 board, 152
 Configuration of the PMC-NA board, 115
 Configuration of the PMC-NA board with or without the conversational function, 118
 Configuration of the PMC-NB board with or without the conversational function, 122
 Configuration of the PMC-NB/NB2 board with or without the conversational function, 126
 Configuration of the power supply unit, 92
 Configuration of the RISC board, 134, 137
 Configuration of the standard multiaxis sub-CPU board (MAX SUB-B), 143
 Configuration of the sub-CPU board (SUB-A), 140
 Configuration of the upgraded main CPU board (MAIN-C), 104
 Configuration of the upgraded sub-CPU board (SUB-C), 146
 Connection to α serial spindle amplifier, 80
 Connection to analog spindle amplifier, 81
 Connections by type of detectors, 77
 Control unit PCB, 164
 Control unit rack, 163
 Conversational data input, 222
 Conversational data input/output, 222
 Conversational data output, 223
 Corrective action for failures, 271
 CRT/MDI unit, 68
 Custom macro variable value input, 218
 Custom macro variable value output, 212
 Cycle start LED signal has turned off, 295

《D》

Data input, 214
 Data input/output, 200
 Data output, 208
 Diagnosis function, 19
 Display data, 36
 Display format of history data, 13
 Display method, 13, 35, 36, 41, 231
 Display of wave diagnosis (graph) screen, 30
 Display unit, 170
 Displaying method, 9
 Displaying system configurations, 9
 Displaying the diagnosis screen, 19

《E》

Editing a displayed waveform, 34
 Environmental requirement, 85

Erasing a displayed waveform, 34
 Error code table, 363
 Error messages and required countermeasures, 355
 Execution period of PMC, 229
 External control unit (except I/O unit), 173

«F»

Fuse replacement in power supply unit, 181

«G»

General of interface, 225

«H»

Handle operation cannot be done, 285
 Handling memory cards, 192
 Hardware, 51
 Help function, 15
 High-speed DI signal interface, 84
 How to replace fan motor, 179
 How to replace the batteries, 177
 How to replace the card cage in the control unit, 191
 How to replace the CRT display, 189
 How to replace the MDI keyboard, 190
 How to replace the modules, 176

«I»

I/O link, 73
 Input and output of data, 196
 Inputting CNC parameter, 214
 Inputting PMC data, 216
 Insertion, 176
 Inter-machine connection, 68
 Interface between NC and PMC, 224
 Internal position compensation data display function, 36
 Investigating the conditions under which failure occurred, 271

«J»

Jog operation cannot be done, 281

«L»

Lighting of alarm LEDs on PCBs, 92
 List of the PCBs and units, 163

LOAD BASIC SYSTEM, 354

«M»

Maintenance of heat pipe type heat exchanger, 182
 Maintenance parts, 329
 Maintenance parts for the FANUC Series 15-B, 330
 Manual pulse generator, 72
 MEMORY CARD FORMAT function, 353
 Memory cards for use with the boot system, 340
 Module (for main CPU board), 166
 Module (for PMC/conversational board), 167
 Module (for RISC board), 168
 Module (for sub CPU board, additional axis board, or axis CPU board), 168
 Module (option 1 board), 169
 Module (OSI ethernet board), 169
 Module information, 12

«N»

Names and functions of the components, 193
 NC status display, 28
 No manual operation nor automatic operation can be executed, 276
 Nothing is displayed on CRT, 297

«O»

Operating monitor screen, 35
 Operation, 15
 Operation history, 41
 Operation list, 46
 Operation of MDI panel, 1, 2
 OSI ethernet board configuration (10 base 2), 156
 OSI ethernet board configuration (10 base 5), 158
 Outline of hardware, 53
 Outputting PMC parameter, 208

«P»

Part program output, 213
 Part program registration, 220
 Pitch error compensation data input, 218
 Pitch error compensation data output, 212
 PMC errors, 388
 PMC screen, 231
 PMC system configuration, 230
 PMCDGN screen, 237
 PMCLAD screen, 233
 PMCRAM screen, 245

Power cannot be turned on, 273
 Power capacity, 86
 Power supply unit, 164
 Power-up processing sequence display, 336
 PS200 (grid synchronous is failed), 311

«R»

Reader/puncher interface, 71
 Reference position deviates, 310
 Related parameters, 45
 Remote buffer interface, 82
 Removing, 176
 Replace the battery for memory back up, 177
 Replacing batteries for separate absolute pulse coder, 178
 Replacing the battery, 195
 Replacing the fuses of the liquid-crystal displays, 187
 Replacing the LCD backlight, 188
 Restrictions, 14

«S»

Screen configuration and operating procedure, 341
 Screen transition chart, 2
 Select DI/DO screen, 44
 Servo interface, 76
 Setting the parameters required for input/output, 197
 Setting the waveform diagnosis parameters, 30
 Signal and symbol correspondence table, 253
 Slot information, 10
 Soft key operation, 41

Software information, 9
 Specification, 226
 Specification of PMC, 226
 SR805 to SR874 (related to reader/punch interface), 298
 SRAM DATA BACKUP screen, 348
 Starting or terminating data sampling, 34
 Starting the boot system, 337
 Structure, 52
 System alarms and required countermeasures, 357
 SYSTEM DATA CHECK screen, 344
 SYSTEM DATA LOADING screen, 342
 SYSTEM DATA SAVE screen, 347
 System file and user file, 338
 System reserve area in internal relay, 228

«T»

Tool offset data input, 219
 Tool offset data output, 213
 Total connection, 56
 Troubleshooting, 270

«U»

Using memory cards, 194

«W»

Warning message list, 395
 Waveform diagnosis function, 30
 Waveform display, 34

Revision Record

FANUC Series 15/150—MODEL B MAINTENANCE MANUAL (B-62075E)

Edition	Date	Contents	Edition	Date	Contents
04	May, '98	Total revision			
03	Feb., '95	The following products are added • FANUC Series 150—TB • FANUC Series 150—TTB • FANUC Series 150—MB			
02	Aug., '94	The explanation of various printed circuit boards was added to the paragraph of the control unit printed circuit boards.			
01	Jan., '93	_____			

- *No part of this manual may be reproduced in any form.*
- *All specifications and designs are subject to change without notice.*